

NCCPS

National Conference on Chemical Process Simulation -2018

CONFERENCE PROCEEDINGS

26 November 2018

Indian Institute of Technology Bombay

Editors:

Kannan M. Moudgalya

P. R. Naren

Daniel Wagner

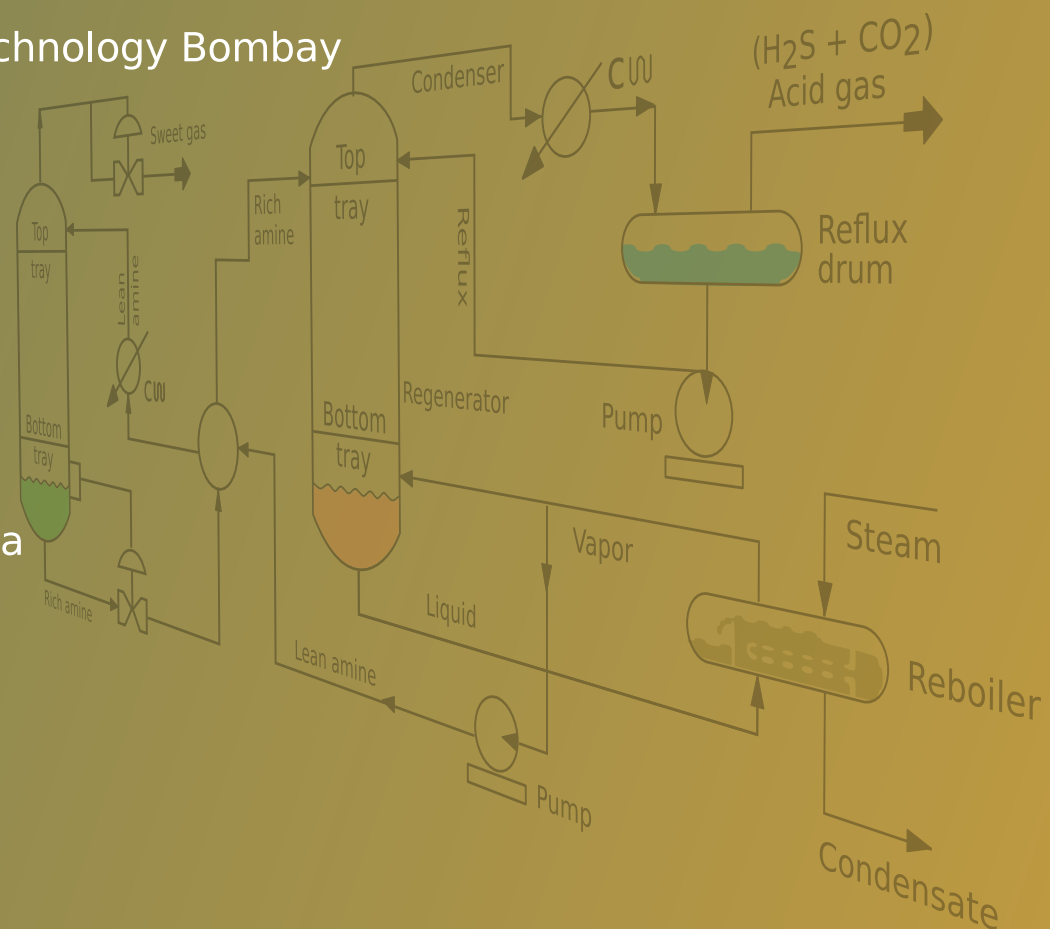

Preface

Welcome to the Proceedings of the first National Conference on Chemical Process Simulation (NCCPS 2018), held at IIT Bombay, on Monday, 26 November 2018. This conference is organised by the FOSSEE team.

FOSSEE stands for Free and Open Source Software for Education. It has been funded since 2009 by the National Mission on Education through ICT, Ministry of Human Resource Development (MHRD), Govt. of India.

Initially, it started as Free and Open Source Software (FOSS) for Engineering Education, which is the reason for the acronym FOSSEE. Because of its achievements, the FOSSEE team was asked by the funding agency to expand its operations to include Sciences in the beginning, and then to accommodate all fields of education. Although the scope has changed, the name has been retained by the FOSSEE team.

The FOSSEE team mainly works on making available the state of the art steady-state open source software systems to the public in general and to students and faculty in particular. Because of the very nature of the work, these resources are available to everyone, anywhere in the world. The FOSSEE team helps add instructional material to the select FOSS systems, through Spoken Tutorials, Textbook Companions, Lab Migration, and select simulation projects, such as flowsheeting (DWSIM), circuit simulation (eSim), Case Study (OpenFOAM), and Power System Simulation (OpenModelica and OpenIPSL).

DWSIM is a state of the art chemical process simulator. It has a large collection of unit operations. It has a CAPE Open compliant thermodynamic database and solution techniques. As this simulator is just about 10 years old, it is created using modern software tools. Because of this reason, it has an excellent interface and it is easy to use this software.

The FOSSEE team also focuses on promoting open source hardware systems, such as Arduino to learn programming, OpenPLC to learn ladder logic and function block programming, and Creation of PCB to connect the eSim based circuit simulation with a real PCB based experimentation. In rare cases, the FOSSEE team also creates new software, such as eSim for circuit simulation, Xcos on the web and Yaksh, an online assessment tool. All of these are available free of cost from <https://fossee.in>.

The objectives of NCCPS are to bring together students and faculty who work in the area of process simulation; to retain the interest of students who want to work in core areas; to enhance their employment potential in core industry; and to identify suitable candidates for recruitment, thereby helping the industry.

These proceedings are organised in two parts. The first part has 11 reviewed papers submitted by people from industry and academia, both students and faculty. Ten of them are based on the FOSS process simulator DWSIM and one is based on the FOSS tool OpenModelica. The second part has a summary of 100 flowsheets solved in DWSIM.

The proceedings themselves are released under the Creative Commons License CC-BY-SA. A soft copy of the proceedings is available for free download. Links for most of the flowsheets explained in the proceedings are also available.

These proceedings are released under Creative Commons CC-BY-SA License. A soft copy of these proceedings are available at <https://fossee.in/nccps-2018>.

We would like to thank Pravin, Priyam and Rahul, without whom, these proceedings would not have been possible within the available time. We also thank the entire FOSSEE team for their wholehearted support.

We invite you and your colleagues/students to participate in this collaborative community development activity.

IIT Bombay
Powai, Mumbai

22 November 2018

Kannan Moudgalya
(IIT Bombay)

P. R. Naren
(SASTRA University)

Daniel Wagner
(Creator of DWSIM)

Contents

1	Papers	7
1.1	Process Modeling of Power Generation in Carbon Black Manufacturing Unit	9
1.2	Elucidating Concepts of Separation Techniques and Thermodynamics in Process Development using DWSIM	12
1.3	Thermo-Mechanical Modeling of Shape and Non-shape Memory Polymers using OpenModelica	17
1.4	Production of Aniline by Hydrogenation of Nitrobenzene	26
1.5	Chlorination of Benzene	30
1.6	Production of Ethyl Chloride from Ethylene and Hydrogen Chloride involving Recycle Stream	34
1.7	Synthesis of p-xylene by Selective Methylation of Toluene	39
1.8	Using “DWSIM” for Understanding Chemical Reaction Equilibrium	43
1.9	Using DWSIM for Analysis of Energy Streams in Process Flowsheets	46
1.10	Effect of Thermodynamic Model Parameters on Simulation of Distillation Column	50
1.11	Multicomponent Distillation and its Sequencing Using DWSIM	56
2	Flowsheets	63
2.1	Nitrogen Liquefaction using Linde Cycle	65
2.2	Production of Methane from Carbon Monoxide and Hydrogen(using Recycle)	65
2.3	Production of Biodiesel	66
2.4	Hydrogen Production through Methane Catalytic Steam Reforming	67
2.5	Solid Carbon Combustion	68
2.6	Pressure Swing Azeotropic Distillation of Methanol-Acetone	69
2.7	Natural Gas Processing Unit	69
2.8	Simple LNG Exchanger Custom Unit Operation	70
2.9	Sour Water Stripping	71
2.10	Removal of Isopentane in Gasoline Manufacturing Plant	72
2.11	Separation of Benzene from Air using Compression	72
2.12	Distillation Of Aqueous Acetone	73
2.13	Open Cycle Steam Turbine	74
2.14	Closed Loop Steam Turbine	75
2.15	Methanol Water Distillation With Preheating	76
2.16	Vapor Compression Refrigeration Cycle	76
2.17	Carnot Engine	77
2.18	A Simple De-Humidification System	78
2.19	A Heat Pump System using CO_2 as Refrigerant(R744)	79
2.20	Benzene Toluene Fractionation Unit	79
2.21	Azeotropic Distillation of Butanol and Water	80
2.22	Separation of Refinery Light Ends	81
2.23	Extractive distillation of Methylal from Methanol using DMF	82
2.24	BTX Separation Chain and Energy Optimization	83
2.25	Esterification of Acetic Acid with Methanol to Methyl Acetate	84
2.26	Process Development for the Production of Mono Propylene Glycol from Propylene Oxide	84
2.27	Separation of Natural Gas	85
2.28	Extractive Distillation of Toluene and Methylcyclohexane using Phenol	86
2.29	Production of Ammonia through Haber’s Process.	87

2.30	Process Development for the Production of Propylene Glycol Monomethyl Ether	88
2.31	Synthesis of Methanol	89
2.32	Production of Benzene via the Hydrodealkylation of Toluene	89
2.33	Esterification of Acetic Acid with 1-Butanol to N-Butyl Acetate	90
2.34	Cumene Production from Benzene And Propylene	91
2.35	Air Separation Unit	92
2.36	Extractive Distillation of Isopropanol and Water System using DMSO as Entrainer	93
2.37	Extractive Distillation of Acetone-Methanol Mixture using Dimethyl Sulfoxide	93
2.38	Heterogeneous Azeotropic Distillation of Ethanol and Water	94
2.39	Production of Formalin from Methanol	95
2.40	Claude Refrigeration Of Methane	96
2.41	Production of Cyclohexane through Catalytic Hydrogenation of Benzene	97
2.42	Dehydration of Ethanol using Glycerol as Entrainer	97
2.43	EthylBenzene production from Ethylene and Benzene	98
2.44	Production of Cumene: Demonstration of Closed Cycle Utility Loop	99
2.45	Methanol Synthesis from Syngas as described by Luyben	100
2.46	Separation of Acetonitrile-Methanol-Benzene Ternary Azeotrope	101
2.47	Tetrahydrofuran-Water Pressure Swing Azeotropic Distillation	102
2.48	TEALARC LNG Refrigeration Cycle for Natural Gas	103
2.49	BTX Divided Wall Column	104
2.50	Energy Efficient Hybrid Separation Process for Acetic Acid Purification	105
2.51	Natural Gas Processing Simulation	105
2.52	Industrial Production of Acetone by Dehydrogenation of Isopropanol.	107
2.53	Pressure Swing Distillation of Isobutanol and N-Heptane	108
2.54	Maleic Anhydride Production from Benzene	109
2.55	Design of an industrial 1,4- Dioxane Dehydration process with light feed impurity	109
2.56	Production of Ethylene Glycol by Non-Catalytic Liquid Phase Hydration of Ethylene Oxide	110
2.57	Pressure Swing Distillation of Acetonitrile-Water System	111
2.58	Separation of Methyl Methacrylate, Methanol and Water	112
2.59	Methanol-Water Separation using Neat Operation	112
2.60	Production of Acetic Acid using Acetaldehyde	113
2.61	Extractive Distillation for Dehydration of Tetrahydrofuran	114
2.62	Production of Monoethanolamine, Diethanolamine, Triethanolamine	115
2.63	Turton Design for Production of Acetone	116
2.64	Production of Diethyl Ether from Ethanol	117
2.65	Production of Ethylene Oxide by Air Oxidation Process	117
2.66	Steady State Simulation of Separation Column for Propylene-Propane Mixture	118
2.67	Cooling of Benzene and Heating of Methane by Circulation of Water	119
2.68	Production of Vinyl Chloride via Direct Chlorination of Ethylene	120
2.69	Pressure Swing Distillation for Methanol - Chloroform Separation	121
2.70	Production of Benzene via HydroDeAlkylation of Toluene	122
2.71	Production of Nitric Acid by Ammonia Oxidation Process	122
2.72	HydroDeAlkylation of Toluene to Benzene	123
2.73	Extractive Distillation for Ethyl Formate-Ethanol-Water Separation	124
2.74	Simulation of C3MR LNG Refrigeration Process in DWSIM	125
2.75	Isopropyl Alcohol Dehydration Process	126
2.76	Benzene-Cyclohexane Separation System via Extractive Distillation	126
2.77	Pressure Swing Distillation System for Methylal/Methanol	128
2.78	Production of Vinyl Chloride from Ethylene	128
2.79	Refrigerated-Purge Distillation Columns	129
2.80	Dry Methane Reforming Process	130
2.81	Control of an Extractive Distillation Process to Dehydrate Ethanol using Glycerol	131
2.82	Study on the Effects of Inerts on Water-Gas Shift Reaction	132
2.83	Production of Styrene from Benzene and Ethylene	133
2.84	Production of N-Octane from Ethylene and I-Butane	134

2.85	Production of Aniline from Nitrobenzene and Hydrogen	134
2.86	Effect of Column Sequence on the Separation of Compounds	135
2.87	Production of Sulfur Trioxide from Sulfur Dioxide	136
2.88	Alkylation of 1-Butene to Octane and Dodecane	136
2.89	Production of Acetic Acid from Acetaldehyde	138
2.90	Bioethanol Purification by Reactive Distillation	138
2.91	Effect of Thermodynamic Models on Separation of Aromatic Compounds	139
2.92	Maximum Boiling Acetone-Chloroform Azeotropic Distillation System	140
2.93	Pressure Swing Distillation for Separation of Tetrahydrofuran-Methanol	141
2.94	Extractive Distillation for Benzene-Acetonitrile Separation using Dimethyl Sulfoxide	142
2.95	Extractive Distillation for Maximum Boiling Ethylenediamine Dehydration System	143
2.96	Pressure Swing Distillation of Toluene - Ethanol	143
2.97	Ethyl Acetate - Ethanol Separation via Extractive Distillation	144
2.98	Production of Dimethyl Ether via Dehydration of Methanol using Cooled Reactor	145
2.99	Production of Ethyl Chloride from Ethylene involving Recycle Stream	146
2.100	New BTX Petlyuk Divided Wall Column	147

Chapter 1

Papers

This chapter presents 10 papers written by students and faculty of top engineering institutions in India. There is also one paper from an industry group. Ten of them are based on open source process simulator DWSIM and one uses OpenModelica. The academic participants have shared their flowsheet as well.

One of the main objectives of this conference is to motivate good engineering graduates to continue to work in the core sector. Students who contributed these papers familiarised themselves with DWSIM or OpenModelica, as the case may be, and simulated their systems. Most of them have also compared their results with an established commercial simulator. This process of using two simulators improves their understanding. The fact that the results match also improves their faith in open source software.

We invited all those who participated in the Flowsheeting project, the topic of discussion of the next chapter, to write papers for this conference. Interestingly, we received papers from many *new* participants. They learnt DWSIM and then wrote the papers presented here. A total of 30 papers were received for the conference. After a review, 11 of them have been selected.

All selected contributors have been asked to make a poster presentation in the conference. Due to lack of time, only a few of them will make oral presentations. There are also two Keynote presentations in the conference, one by Prof. K. P. Madhavan, an Emeritus Professor at IIT Bombay and the other by Mr. Alok Pandit of Equinox Software Services.

We hope to expand on the collaborative work reported in these proceedings, especially, in the next chapter. As many of the industry beneficiaries of the simulation work are expected to be small and medium scale companies in India, batch process handling capability is essential. Towards this end, we are working on the process simulation capability of OpenModelica, a general purpose modelling and simulation tool, capable of handling differential, algebraic, and differential algebraic equations. We are working on the possibility of porting all the 100 flowsheets reported in the next chapter to OpenModelica. We expect the top groups that contributed papers to this conference to take up this challenge.

In this Conference, we have organised a Job Fair for students who participated in the simulation work. Leading chemical and oil companies and engineering consulting companies are participating in this Job Fair. As mostly students who have done good work in the simulation area will participate in the job interview, chances of hiring good candidates are high for the industry.

Process modeling of power generation in Carbon Black Manufacturing unit

Jogesh Mankar
Process Engineering
Aditya Birla Science and Technology
Company Ltd, MIDC Taloja, India
jogesh.mankar@adityabirla.com

Eishan Puranik
Technical and Development Cell
Birla Carbon (I) Pvt Ltd
Patalganga, India
eishan.puranik@adityabirla.com

Abstract: The total power generated in the carbon black manufacturing unit is 10 to 18 MW depending on nature of grades and productivity. Plant self-power consumption is constant irrespective of productivity and grade which is being produced. Unit sells excess power to various customers via open access but needs to intimate to the power grid on day ahead basis about their target power supply. Plant has to bear the penalty for not meeting the target supply. Also, Plant has to suffer revenue losses for more power supplied than intimated as revenue of this excess power is negligible compared to revenue received by intimated power export. Here process model can help in obtaining better estimation of power generation over a period for better value realization. Process model is developed for one grade for better estimation of power generation in carbon black manufacturing unit at different operating conditions using DWSIM. As power consumption remains same, power export capability can be identified on regular basis. This model is validated with the plant data as well Aspen plus model predictions for different grades and for different operating conditions. The DWSIM model predictions are in good agreement with the plant data and Aspen plus model predictions. The application of this model is in better estimation of power generation for power sell planning in open access on day a-head basis to reduce power export revenue losses.

Keywords: DWSIM, Aspen Plus, power generation, Carbon Black

I. INTRODUCTION

Carbon black (CB) is commercially produced by partial combustion and thermal pyrolysis of hydrocarbons. It is produced in highly controlled environment to produce particles of varied structure and surface chemistry. It is used as an additive in diverse applications (tire, rubber, plastics, printing inks, paints, etc.) to enhance their mechanical, electrical or optical properties [1,4].

In this process, carbon black feedstock (CBFS) is injected through atomizers into highly turbulent gases at high temperature to achieve vaporization of droplets, subsequent gaseous pyrolysis and ultimately carbon black particle formation in the form of smoke (particle laden gas). Reaction is stopped by direct addition of water as a quench because of which, temperature of smoke is reduced. This smoke mainly consists of carbon black agglomerates, Carbon Monoxide (CO), Hydrogen (H₂), Nitrogen (N₂) and water vapours (H₂O). This smoke is further passed through membrane bag filters from which carbon black is separated from off-gases. This off-gas (say, tail gas) contains certain calorific value because of presence of Hydrogen and Carbon monoxide [1]. Therefore, tail gas is consumed in boiler for high pressure steam generation. Generated steam is used for power generation with the help of steam turbines.

The objective of this work is to estimate the power generation during carbon black manufacturing process. The objective of the power generation estimation is to plan the

quantum of power which needs to be planned on day ahead basis to sell to third party power consumers through power exchange and get maximum revenue through power sell. Presently, the power generation in the manufacturing unit varies from 10 MW to 18 MW as it mostly depends on the raw material quality, productivity as well as type of carbon black grade being produced.

In present scenario, unit has to commit and bid the quantum of power export in open access market on day ahead basis. As unit consumes fixed quantum of power for its own operations, estimation of power generation is desired to get quantum of additional available power to sell in open access market.

The potential benefits of the process model are as follows:

1. Achieving committed power export reduces revenue losses due to penalty charges on short power supply
2. Increase in power export revenue due to reduction in excess power export than committed export
3. Captive Power Plant (CPP) performance evaluation on regular basis at plant level.

II. PROCESS DESCRIPTION

Figure 1 shows the process flow diagram for power generation section. This section comprises of Boiler combustor, Super-heater, Evaporator boiler, Economizer, and steam turbine generator.

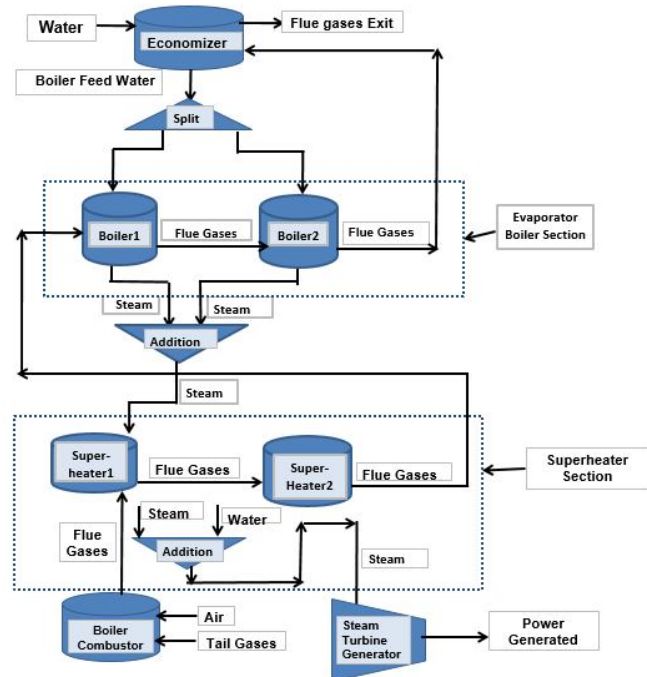

Fig. 1. Process flow diagram for power generation section

Boiler combustor: The purpose of boiler combustor is to generate combustion gases with high temperature. Air and flue gases are fed to boiler combustor, wherein flue gases undergo combustion. The output from the boiler combustor is the combustion gases. These combustion gases are then fed to super heater as a heating medium.

Super-heater: The purpose of super-heater is to generate superheated steam. The inlet streams to the super heater section (superheater1 and superheater2) are steam from Evaporator Boiler section and flue gases. The outlet streams from super heater are flue gases and steam. The flue gases are fed to Evaporator Boiler and steam is fed to steam turbine generator (STG) wherein power is generated.

Evaporator Boiler: The purpose of evaporator boiler is to generate steam. The inlet to the evaporator boiler section (boiler1 and boiler2) are boiler feed water (BFW) from Economizer and flue gases from super heater section. The outlet streams from evaporator boiler section are flue gases and high pressure (HP) steam. Flue gases from evaporator boiler section are fed to Economizer and steam is fed to super heater section.

Economizer: The input streams to economizer are water and flue gases which are coming from evaporator boiler. The output streams are heated water and flue gases exit. The flow direction to economizer is countercurrent mode. The purpose of economizer is to heat the water to desired temperature. The output streams from economizer are boiler feed water (BFW) which is fed to evaporator Boiler (boiler1 and boiler2) and flue gases which are fed to stack.

Steam Turbine: The purpose of steam turbine is to generate power utilizing the superheated steam coming out from superheater.

III. PROCESS MODEL DEVELOPMENT AND VALIDATION IN DWSIM

DWSIM open-source process modeling software has been used to develop the process model for power generation in carbon black plant. DWSIM possesses the required model libraries for developing process model for power generation section [2]. The major inputs to the DWSIM and Aspen Plus power generation process model are tail gas flow rate and its composition, air flow rate and BFW flow rate [3].

The property method utilized for process model development in DWSIM and Aspen Plus model is Peng-Robinson.

The boiler combustor is modelled using conversion reactor. The combustion reactions of CO and H₂ are incorporated in the boiler combustor model. The super-heater, evaporator boiler and economizer are modelled using shell and tube heat exchanger. The steam turbines are modelled using adiabatic expander. The design data of super-heater, evaporator boiler, and economizer is utilized for modelling and operating data is utilized for heat loss adjustments.

Figure 2 shows the process model developed for power generation estimation in DWSIM.

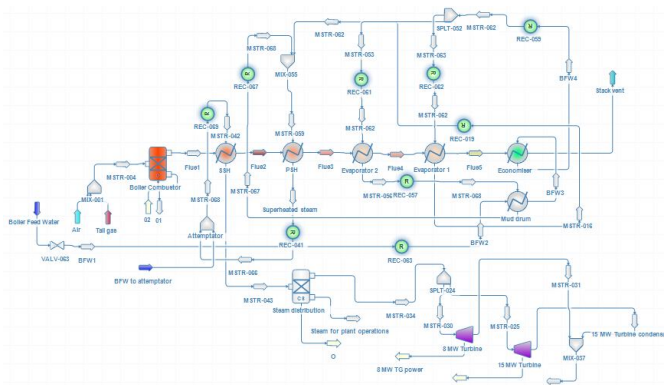

Fig. 2. Process model for power generation in DWSIM

IV. VALIDATION OF DWSIM PROCESS MODEL

Table 1 shows the results for the validation of developed process model for one grade with the plant data

Process variables	UOM	Input values to Model		
Tail Gas Flow	Nm ³ /hr	50000 to 80000		
Tail Gas Temperature	⁰ C	200 to 300		
Air Flow	Nm ³ /hr	40000 to 60000		
Air inlet Temperature	⁰ C	60		
Feed Water Flow	kg/hr	50000 to 70000		
Comparison: Prediction v/s actual data	UOM	Aspen Plus Model	DWSIM Model	Actual Plant Data
Combustion Gases Temperature	⁰ C	1171	1208	1164
Steam temperature at Superheater1 outlet	⁰ C	431	440	434
Flue Gas Exit Temperature from Economizer	⁰ C	213	224	198
Power Generation	MWh	13.78	14.074	13.84

DWSIM possess models in its library required for the development of process model for power generation section. The models used for process model development are conversion reactor, shell and tube heat exchangers and adiabatic expanders. The super-heater, evaporator boiler and economizer are modelled using shell and tube heat exchangers in DWSIM and Aspen Plus model. The boiler combustor is modelled using conversion reactor in DWSIM and Aspen Plus model. The results of power model in DWSIM are in good agreement with that of Aspen Plus model.

CONCLUSIONS

Process model is developed for one grade for power generation section in DWSIM. The model is validated with the plant data and Aspen Plus model predictions. The model results are in good agreement with the plant data and Aspen Plus model predictions. The application of this model is in the better estimation of power generation in the plant to reduce power export revenue losses. The way forward is to develop the process model for other major grades, its validation with the plant data and Aspen model predictions

and its application for better estimation of power generation in the plant.

REFERENCES

- [1] J.B. Donnet, R.C. Bansal, M.J. Wang, "Carbon black science and technology", second edition, 1993.
- [2] P. R. Naren, "PROCESS SIMULATION USING DWSIM: A Free and Open Source Chemical Process Simulator", 2017. <https://sites.google.com/site/prnarenportal/dwsim>.
- [3] A.K. Jana, "Process simulation & control using ASPEN", 2/e. New Delhi: PHI Learning Pvt. Ltd., 2012.
- [4] S. Satav, V. Yakkundi, V. G. Badhe, A. Gaikwad "Investigation of Innovation in Carbon Black Manufacturing in the realm of Green Environment", Volume5 Issue3, International Conference On Emanations in Modern Technology and Engineering (ICEMTE-2017).

Elucidating Concepts of Separation Techniques and Thermodynamics in Process Development using DWSIM

S. Aakash Subramanian
School of Chemical & Biotechnology
SASTRA Deemed to be University
Thanjavur, Tamil Nadu, India
akashsubramanian@live.com

P. R. Naren*
School of Chemical & Biotechnology
SASTRA Deemed to be University
Thanjavur, Tamil Nadu, India
prnaren@scbt.sastra.edu

Abstract— Simulation is an integral part in development and analysis of a chemical process. A chemical process simulator serves as a tool to design equipment, to better understand the process and to optimize the process parameters. It can also be used as a learning tool to demonstrate the applications of chemical engineering concepts of separation techniques, thermodynamics, etc. in different process units. “DWSIM”, a free and open-source steady-state chemical process simulator is used in the present work to simulate chemical process units with the objective to illustrate their usefulness in process development and learning of chemical engineering concepts. DWSIM consists of various blocks like material and energy streams, heater, distillation column, etc. It also contains various thermodynamic packages to construct flowsheets for the development of a chemical process. In the present work, flowsheets consisting of blocks such as distillation column, gas-liquid separator and recycle are developed for the production of some of the industrially important chemicals. The objective of the work is to elucidate some of the concepts of separation techniques and design of process equipment. Further, a process flowsheet is simulated using different thermodynamic packages in order to show the importance of choosing an appropriate thermodynamic model for simulation. The results obtained from DWSIM are compared with “Aspen Plus”, a licensed chemical process simulator and are found to be in good agreement with one another.

Keywords—Chemical Process Simulator, Flowsheet, Thermodynamics, DWSIM, Aspen Plus

I. INTRODUCTION

Development of a chemical process requires thorough understanding of the principles involved in each of the unit operations and processes. The primary step involved in the design of process equipment for any unit operation is the formulation of mass and energy balances across the unit operation in the form of mathematical equations. The next step involves solving of these equations to obtain the necessary output parameters. In most situations, such a step involves tedious calculations and cannot be carried out manually. In such situations, there is a need for a tool to perform the calculations. A chemical process simulator is a tool used widely to perform such calculations across all the unit operations involved in the process [1].

A. Chemical Process Simulator

A chemical process simulator is a tool to simulate and analyze chemical processes. It consists of various built-in blocks that represent various unit operations. Further, chemical process simulator contains thermodynamic

packages that are also built-in to compute the thermo-physical properties of pure components and mixtures. These built-in blocks are connected in sequence to develop process flowsheets that mimics the material and energy flow of a chemical plant. The constructed flowsheet is then simulated to obtain the necessary results. Additionally, simulating the flowsheet under different conditions aids to determine the operating conditions and design parameters required to achieve targeted outputs.

B. DWSIM

“DWSIM” is a free and open-source chemical process simulator that can simulate chemical processes under steady state conditions. It follows the sequential modular approach. It is typically used for simulation problems, where for a given input to a process unit the output is computed. It does not support direct simulation of chemical processes under dynamic or transient state. DWSIM consists of various built-in unit operations such as mixer, heater, distillation column, etc. represented in the form of blocks. These blocks are connected with each other to construct a flowsheet in such a way that the flowsheet mimics the process exactly. Fig. 1 shows a simple flowsheet constructed using DWSIM for separation of mixture containing benzene and chloroform into its components. It also contains various thermodynamic packages that can be applied to simulate a chemical process. It also has a user-friendly Graphical User Interface (GUI) through which users can enter input parameters and view the necessary outputs [2].

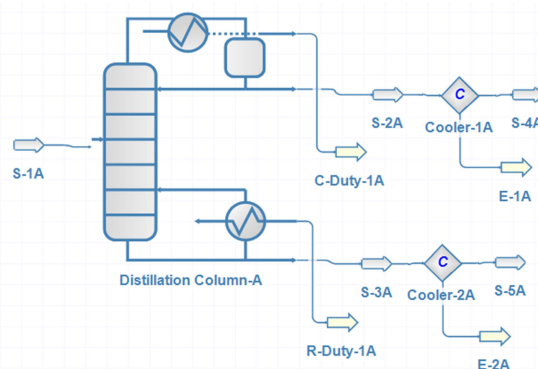

Fig. 1. A flowsheet constructed using DWSIM for separation of mixture containing benzene and chloroform into its components

In this work, flowsheets for the production of a few of the industrially important chemicals such as styrene, N-octane and N-dodecane are constructed and simulated. These flowsheets consists of unit operations such as distillation column, heater, cooler, mixer, gas-liquid separator, recycle, etc. Of the unit operations used, one of the unit operations, distillation column, is simulated using two different thermodynamic packages (Raoult's Law and Peng - Robinson) in order to demonstrate the effect of choice of thermodynamic model on the design of the column. The objective of the present work is to elucidate some of the basic principles of separation techniques, design of process equipment and thermodynamics in different process units.

II. METHODOLOGY

In this work, flowsheets for the production of styrene and N-octane and separation of benzene-chloroform mixture are constructed and simulated. The operating conditions to be specified as input parameters for the simulation of these flowsheets are adapted from literature [3][4][5]. The results obtained from the simulation of the flowsheets are then compared with those obtained from a commercially available chemical process simulator, Aspen Plus (v8.6, Aspen Tech Inc., USA).

Case Study 1: Process flowsheet for production of styrene

The process initially involves a reaction between ethylene and benzene to produce ethyl benzene. Later, ethyl benzene is dehydrogenated to produce styrene. The unreacted components, ethylene and ethyl benzene are recycled to increase the productivity of the process.

The process flowsheet for the production of styrene consists of unit operations such as reactor, heater, gas-liquid separator, distillation column, etc. For the sake of simplicity, a "Conversion Reactor" block is used. The unit operation block focused in this part of the work is distillation column.

At first, "Shortcut Column" is used for the separation of styrene from other compounds. Later, the output obtained from the simulation of the shortcut column is used to specify the input parameters required for the simulation of "Rigorous Distillation Column".

Case Study 2: Process flowsheet for production of N-octane

The process involves hydrogenation reaction in which two molecules of 1-butene are made to react with a molecule of hydrogen to produce N-octane.

The flowsheet developed for the process is quite simple. Since the reaction involved in this process is an equilibrium reaction, an "Equilibrium Reactor" block is used. In this case study emphasis is laid on "Gas-Liquid Separator" block that is mainly used to separate a fluid stream into gas and liquid streams. The separation process mainly depends on the physical state of the compounds present in the stream at the given operating conditions and also determined by phase equilibrium calculations.

Case Study 3: Process flowsheet for separation of mixture containing benzene and chloroform

In this flowsheet, a mixture containing benzene and chloroform is separated by using a "Rigorous Distillation Column".

This process flowsheet is simulated using two different thermodynamic packages, namely Raoult's Law and Peng – Robinson (PR) to study the effect of thermodynamic package on the design of the distillation column.

The flowsheets for all the processes mentioned above can be found from 'FOSSEE Flowsheets' tab present in the 'Quick Access' window in DWSIM or the 'FOSSEE DWSIM' portal [6].

III. RESULTS AND DISCUSSION

The flowsheets are simulated using DWSIM (v5.3) for specified inputs. The results obtained from simulation of the flowsheets are then validated with those obtained from Aspen Plus (v8.6, Aspen Tech Inc., USA).

The flowsheet for the production of styrene from ethylene and benzene is simulated at a temperature of 650 °C and 1.01325 bar pressure [7]. Fig. 2 shows the flowsheet constructed for the production of styrene from benzene and ethylene using DWSIM.

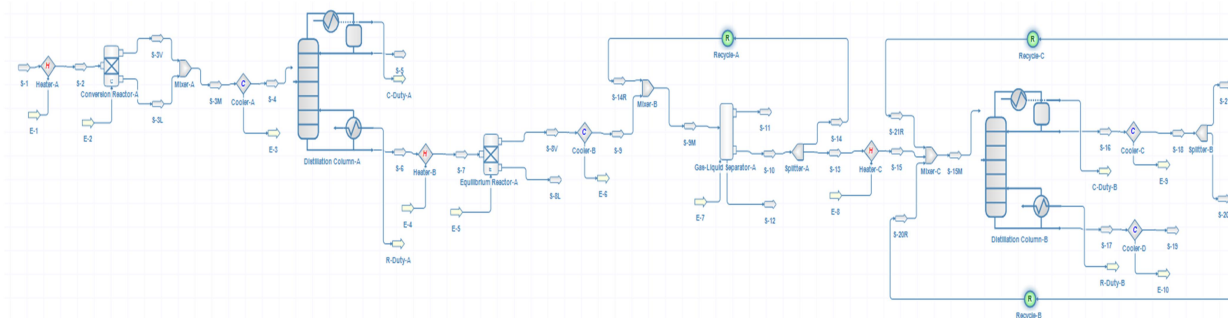

Fig. 2. Flowsheet in DWSIM for production of styrene from benzene and ethylene

The “Shortcut Column” and “Rigorous Distillation Column” blocks are focused in this case study in order to show that DWSIM can be used as a tool to design chemical process equipment. Initially, a shortcut column is simulated using DWSIM and Aspen Plus. The results obtained from the simulation of the shortcut column by using DWSIM and Aspen Plus are shown in Table 1. It is observed from Table 1, that the results obtained from DWSIM and Aspen Plus are in good agreement with each other.

TABLE 1

Results obtained from simulation of shortcut column using DWSIM and Aspen Plus

Parameters	DWSIM	Aspen Plus
Minimum number of stages	4	4
Actual number of stages	5	5
Location of feed stage	2	3

The results obtained from the simulation of the shortcut column is then used to specify input parameters such as actual number of stages, location of feed stage, reflux ratio and molar flow rate of the bottom stream for the simulation of rigorous distillation column. Also, the results of the simulation of rigorous distillation column using DWSIM are validated with those obtained from Aspen Plus and the results are found to be in good agreement with each other. The bottom stream obtained from the distillation column contains 99.94% pure styrene.

Similarly, the process flowsheet for the production of N-octane is constructed and simulated using DWSIM [8]. Fig. 3 shows the flowsheet constructed using DWSIM for the production of N-octane.

In this flowsheet, gas-liquid separator is used to separate unreacted hydrogen from N-octane and 1-butene. Hydrogen being a gas is obtained as a part of the vapor stream. The results obtained from the simulation are presented in Table 2. From Table 2, it is noted that the concentration of hydrogen in the gas stream is quite high when compared to that in liquid stream.

TABLE 2

Results obtained from simulation of gas-liquid separator

Molar fraction (mixture)	Vapor Outlet	Liquid Outlet
1-butene	0.4555	0.4628
Hydrogen	0.5414	2.3068E-05
N-octane	0.0031	0.5372

In order to elucidate the importance of thermodynamics on the design of process equipment, a process flowsheet is developed for the separation of benzene and chloroform and simulated using two different thermodynamic packages, namely Raoult’s Law and Peng – Robinson (PR), available in DWSIM. Two separate sequences of flowsheet are simulated under respective thermodynamic packages [9]. Fig. 4 and Fig. 5 shows the two flowsheets simulated for the separation of mixture containing benzene and chloroform into its components under Raoult’s Law using DWSIM and Aspen Plus respectively.

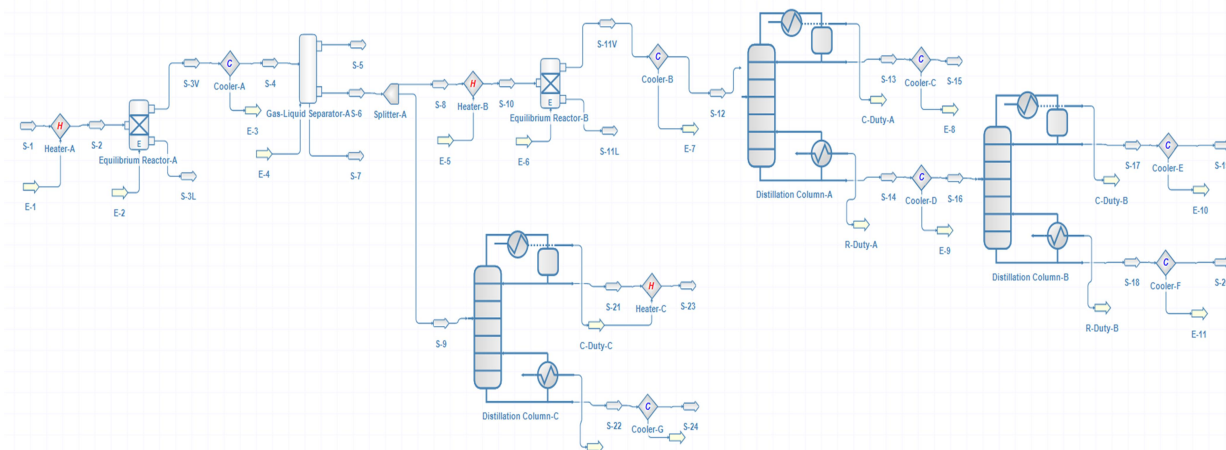

Fig. 3. Flowsheet in DWSIM for the production of N-octane

Case A: Thermodynamic Package: Raoult's Law

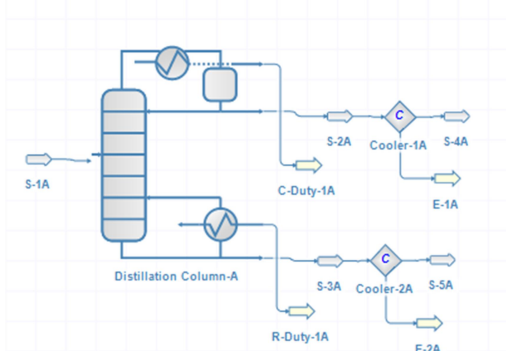

Fig. 4. Flowsheet in DWSIM for the separation of mixture containing benzene and chloroform into its components under Raoult's Law

Case A: Thermodynamic Package: Raoult's Law

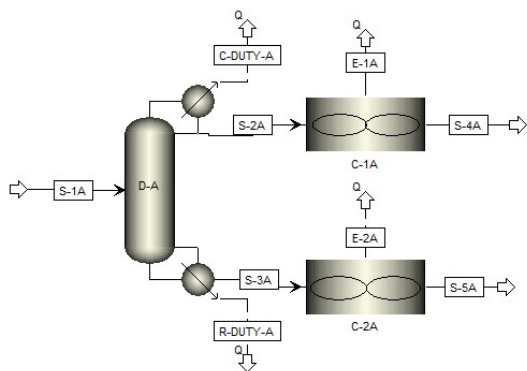

Fig. 5. Flowsheet in Aspen Plus for the separation of mixture containing benzene and chloroform into its components under Raoult's Law using

Similarly, Fig. 6 and Fig. 7 shows the two flowsheets simulated for the separation of mixture containing benzene and chloroform into its components under Peng – Robinson thermodynamic package using DWSIM and Aspen Plus respectively.

Case B: Thermodynamic Package: Peng-Robinson

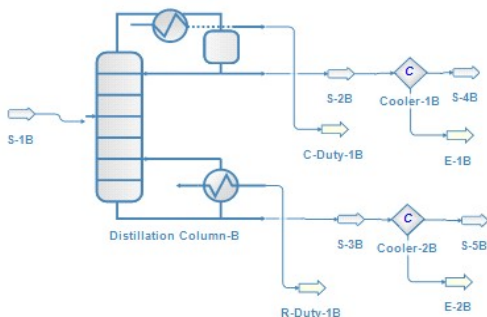

Fig. 6. Flowsheet in DWSIM for the separation of mixture containing benzene and chloroform into its components under Peng – Robinson (PR) thermodynamic model

Case B: Thermodynamic Package: Peng - Robinson

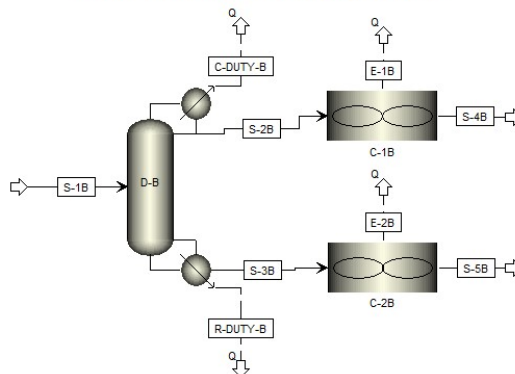

Fig. 7. Flowsheet in Aspen Plus for separation of mixture containing benzene and chloroform into its components under Peng – Robinson (PR) thermodynamic model

The results obtained from the simulation in DWSIM are listed in Table 3. It is observed from Table 3 that the actual number of stages is higher in sequence simulated using Peng – Robinson model than that simulated using Raoult's Law. However, the reflux ratio required for the same degree of separation of components of the system is higher in the sequence simulated using Raoult's Law than that simulated using Peng – Robinson model.

TABLE 3

Results obtained from the simulation of rigorous distillation column under two different thermodynamic packages namely, Raoult's Law and Peng – Robinson (PR) using DWSIM

Parameters	Thermodynamic packages	
	<i>Raoult's Law</i>	<i>Peng-Robinson</i>
Condenser pressure (bar)	1.01325	1.01325
Reboiler pressure (bar)	1.01325	1.01325
Number of stages (-)	17	21
Reflux ratio (-)	5.75	5.00

The results obtained from the simulation of both the sequences of the flowsheet using DWSIM are then compared with those obtained from Aspen Plus respectively. The results of the distillate stream obtained from the simulation of rigorous distillation column under Peng – Robinson thermodynamic package using DWSIM and Aspen Plus are presented in Table 4. It is noted from Table 4 that the deviation of the results obtained from DWSIM with respect to those obtained from Aspen Plus is with acceptable limits of 1%. Efforts to reason out the differences between DWSIM and Aspen Plus simulation results are not focused as part of this work and shall be taken up as further work.

TABLE 4

Results of distillate stream obtained from the simulation of rigorous distillation column under Peng – Robinson (PR) thermodynamic package using DWSIM and Aspen Plus

Parameters	DWSIM	Aspen Plus
Temperature (K)	335.2134	334.8860
Pressure (bar)	1.01325	1.01325
Molar flow (kmol/hr)	5.0617	5.0617
Mass flow (kg/hr)	599.2059	600.3490
Molar fraction (mixture)		
Chloroform	0.9758	0.9813
Benzene	0.0242	0.0187

From the simulation of the rigorous distillation column using the two thermodynamic models, the concentration of one of the components of the mixture, benzene, is obtained at each stage. Fig. 8 shows the concentration profile of benzene across the stages of the rigorous distillation column simulated under the two thermodynamic packages using DWSIM.

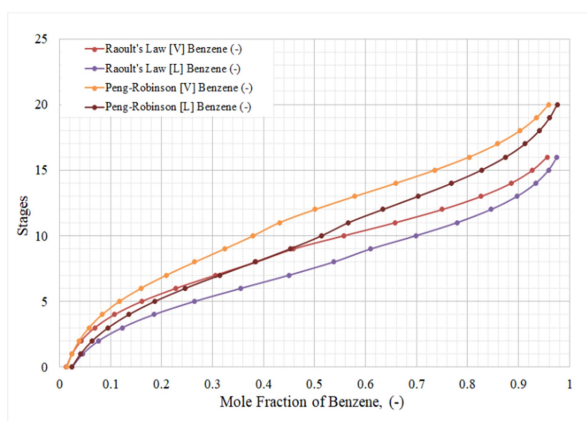

Fig. 8. Concentration profile of benzene across the stages of the rigorous distillation column simulated under the two thermodynamic packages using DWSIM

From Fig. 8, it is clearly observed that at any stage the concentration of benzene computed by the thermodynamic package, Raoult's Law, is higher than that calculated by Peng-Robinson model. Hence, the number of stages of the rigorous distillation column required for the same degree of separation of benzene is calculated to be higher under Peng-Robinson model than that obtained under the thermodynamic package, Raoult's Law.

IV. CONCLUSION

DWSIM, a steady-state chemical process simulator can be used as a tool to construct and simulate flowsheets that represents a chemical process. In the present work, three different flowsheets that consist mainly of three different unit operations are constructed and simulated using DWSIM. The results obtained from the simulation of the flowsheets using DWSIM are in agreement with those obtained from Aspen Plus. This work is carried out in order to elucidate that a chemical process simulator,

like DWSIM, can be used as an aid to demonstrate some basic concepts of separation techniques, design of process equipment and thermodynamics. Thus it can be used as an effective learning tool to complement classroom learning of separation process principle in a typical undergraduate chemical engineering curriculum.

V. ACKNOWLEDGEMENT

I, Aakash, wish to thank Priyam Nayak, Assistant Project Manager, FOSSEE, IIT-B, Mumbai and A. S. Rahul, Project Research Assistant, FOSSEE, IIT-B, Mumbai for their continuous support and guidance in development of these flowsheets.

REFERENCE

- [1] Cai Z., Wang J., Chen Y., Xia L. and Xiang S., The Development of Chemical Process Simulation Software According to CAPE-OPEN. Chemical Engineering Transactions, 2017, vol. 61, p 1819-1824.
- [2] http://dwsim.inforinside.com.br/wiki/index.php?title=Main_Page
- [3] <http://nptel.ac.in/courses/103103029/24>
- [4] Luyben W.L., Design and Control of an Autorefrigerated Alkylation Process. Industrial & Engineering Chemistry Research, 2009, 48, 11081-11093.
- [5] Claudia Gutiérrez-Antonio, Gustavo A. Iglesias-Silva and Arturo Jiménez-Gutiérrez, Effect of Different Thermodynamic Models on the Design of Homogeneous Azeotropic Distillation Columns. Chemical Engineering Communications, 2008, 195:9, 1059-1075.
- [6] <https://dwsim.fossee.in/flowsheeting-project/completed-flowsheet>
- [7] <https://dwsim.fossee.in/flowsheeting-project/dwsim-flowsheet-run/205>
- [8] <https://dwsim.fossee.in/flowsheeting-project/dwsim-flowsheet-run/163>
- [9] <https://dwsim.fossee.in/flowsheeting-project/dwsim-flowsheet-run/214>

THERMO-MECHANICAL MODELING OF SHAPE AND NON-SHAPE MEMORY POLYMERS USING OPENMODELICA

Nikhil Sharma
Department of Petroleum
Engineering
Rajasthan Technical University
Kota, India
nikhilsharma1207@gmail.com

Prof. Pratyush Dayal
Department of Chemical
Engineering
Indian Institute of Technology
Gandhinagar, India
Pdayal@iitgn.ac.in

Abstract— Shape memory materials are a special class of material that have an ability to retain their intended shape when the stimuli causing the shape change is reversed. In the current work, we demonstrate that two non-shape memory polymers when mixed can exhibit shape memory effect. Our model is represented by a viscoelastic system consisting of combinations of springs and dashpots, the mechanical properties of which change with temperature. In the current study we take two materials, wax and rubber, and use their mechanical properties to simulate the shape memory cycles using OpenModelica. Separately Rubber and Wax do not show shape memory phenomena. When mixed rubber and wax, the system shows shape memory effect. Moreover, the results of simulation with OpenModelica for predicting the behavior of viscoelastic model are in agreement with experimental results showing shape memory nature of the model, which is similar to the polyurethane a known shape memory polymer.

I. INTRODUCTION

Shape memory polymers are the special class of materials that have the ability to memorize their intended shape when deformed on application of stimuli [1]. These polymers are fixed to a stable temporary shape on deforming under the application of stimuli and remain in that temporary shape even after the removal of deforming force and returns to its original shape again on application of stimuli. Stimuli can be thermal, chemical (change in pH, bonds and crosslinks), light, electric, and magnetic. Thermal stimuli brings change in structure above a certain temperature called transition temperature. This transition can be glass transition or melting transition [2]. Polyurethane, Polyethylene terephthalate etc. are the examples of some shape memory polymers [3]. Compounds containing cinnamic groups show shape memory phenomena with light as stimuli. The electro-active and magnetic-active uses resistive and inductive joule's heating as stimuli.

A. Application of Shape Memory Polymers

Shape Memory Polymers have applications include industrial [4][2], biomedical [5][6][7], self-healing [8], aerospace

B. Mechanism of Shape Memory Effect

The mechanism of the shape memory effect depends on the type of material and the stimuli. Here we consider a generic mechanism which is applicable to most of the process of shape memory effect. Heating as stimuli is used in this mechanism [1]. Initially, polymer is at room temperature and generally plastic, then upon heating above the transition temperature say “glass transition” or “melting transition” this material becomes flexible due to increased mobility of the molecular chains and allows easy deformation on the application of external force. This deformation leads to change in conformation of molecular chains or change in entropy. On cooling back to a temperature below transition

temperature the deformation is maintained even after the removal of deforming force. This is due to the freezing or immobility of molecular chains at lower temperatures, which results in the storage of entropic energy in the system. This gives a stable shape to the system until heated above the transition temperature without external force. If heated above the transition temperature the material recovers its original shape. Again on heating the mobility of molecular chains increases, which releases the stored entropic energy result in shape recovery and the molecular chains are brought to the highest entropic level which corresponds to the permanent shape. Thus the shape memory effect is the entropic phenomena [9].

Shape memory polymers should meet two basic structural requirements, i.e. netpoints and switch segments. Net points are responsible for permanent shape and storage of energy on cooling the material below the transition temperature. These netpoints can be chemical covalent bonds such as H-bonding, metal ligand interaction or any physical interaction (crystallites).

Switch segments are related to transitions which is reversible i.e. glass transition or a melting transition.

Thus netpoints governs the permanent shape and stores energy which can be released on application of stimuli and switch segment are responsible for stable temporary shape which is reversible [9].

C. Modeling of Shape Memory Effect in Polymers

Various models have been proposed based on the Viscoelasticity, storage deformation, and phase transition. Lin Model [10], Tobushi Model [11], Abrahamson Model [11] are known for describing shape memory polymers with viscoelasticity. Lie et al. model is based on storage deformation which consists of two phases active and frozen phase [12]. According to this model, there are three phases, unlike two in model based on storage deformation. It assumes that glass phase formed on cooling the polymer has different stress free configuration and the glassy phase can be divided into two phase i.e. initial and frozen glassy phase. And the third phase is frozen phase.

D. Steps Involved in Thermo-Mechanical Cycle

1. **Initial conditions:** Initially material is heated above the transition temperature (generally 20°C more than T_g) under stress free condition. Strains at this level is considered zero for reference. This initial shape is considered as the permanent shape of the material.
2. **Step-I:** Material is stressed at temperature above the transition temperature: The temperature is fixed at certain high value say “T_{max}” and the strain is increased at constant strain rate say ”S1” and the material is deformed to give it a temporary shape.

3. **Step-II:** Cooling and maintaining strain: In this step strain is kept constant and the temperature is lowered below the transition temperature at a certain specified rate. At this stage material is fixed in its temporary shape which is stable until heating at higher temperatures.
4. **Step-III:** Removal of external stress: Temperature is kept constant i.e. below the transition temperature and the stress is gradually brought to zero at a certain specified rate.
5. **Step-IV:** Heating for recovery: At this stage the material in previous stage is heated above the transition temperature, the strain energy stored is slowly released and the material returns to its permanent shape [13].

II. MODEL FORMULATION

As the word viscoelastic suggests viscous and elastic, thus a viscoelastic material exhibits both kinds of behaviour i.e. fluid and solid. There are various models available to represent viscoelastic material by the combinations of the linear elastic spring and the linear viscous dashpot..

A. Combination of Wax and Rubber

Standard Linear Viscoelastic Model represents the combination of Wax and Rubber. Basically it is a Maxwell model which is combined in parallel with linear spring model. The series combination of linear spring and dashpot represents Waxes as it is both viscous and elastic in nature [14] [15]. Rubber is completely elastic in nature and simply represented by linear spring model [16].

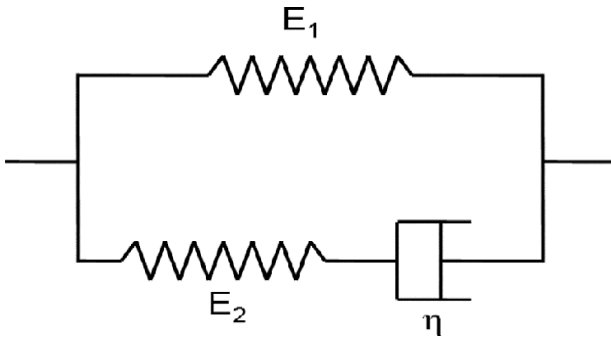

Figure 2.1 The Standard Linear model[14]

The mathematical equation governing the model is represented by:

$$\sigma + \frac{\eta}{E} \dot{\sigma} = E_1 \varepsilon + \frac{\eta(E_1 + E_2)}{E_2} \dot{\varepsilon} \quad (2.1)$$

Where,
 $\sigma, \eta, \varepsilon, E_1, E_2$ are stress, viscosity, strain, Modulus of rubber and wax respectively.

B. Properties of Waxes

Waxes are organic compounds containing higher alkanes. They melt at a melting range and do not have a fixed melting temperature due to varying chain composition. As the no. of carbon atom increases the density and melting point of wax decreases. The melting range of various waxes is as follows[14]:

Paraffin waxes: 50-70°C.

Bees: 60-70°C

Carnauba: 65-90°C

Microcrystalline wax: 65-90°C.

Elastic Modulus of Wax with Temperature:

Elastic modulus of waxes decreases with increase in temperature[15], mainly this is attributed to the variation in the degree of crystallinity. The data is obtained from the literature and the curve is fitted for evaluation of parameters. Parameters of fitted curve are:

$$E = a \times \exp(b \times T) \quad (2.2)$$

Coefficients (with 95% confidence bounds):

$$a = 7.444e+37 (-8.372e+38, 9.861e+38)$$

$$b = -0.2284 (-0.2695, -0.1873)$$

Where, E is the modulus of elasticity, and T is temperature

Viscosity of Wax with Temperature:

Viscosity of waxes decreases with temperature and at transition temperature there is extensive variation in viscosity. There are various methods for determining variation of viscosity of wax with temperature such as falling ball method using stoke's law, rheometer test and viscometer tests are mainly used

The curve fitting parameters are as follows:

$$\eta = e \times \exp(f * T) \quad (2.3)$$

Coefficients (with 95% confidence bounds):

$$e = 8.366e+48 (-2.098e+50, 2.265e+50)$$

$$f = -0.2968 (-0.383, -0.2106)$$

Where, η is the modulus of elasticity, and T is temperature

C. Properties of Rubber

Rubber is generally not crystalline in nature, however natural rubber possesses a very low amount of crystallinity. So we can neglect the effect temperature on crystallinity of rubber.

Modulus of Rubber with Temperature:

Modulus of rubber varies from 0.7×10^{-3} to 4×10^{-3} Mpa. Various experimental results are available for determining the elasticity of rubber and from the knowledge of elasticity the elastic modulus can be found out. In this experiment rubber is stretched at varying temperature with loads and variation in elasticity is measured [16]. The results of curve fitting are:

$$M = g \times \exp(h * T) \quad (2.4)$$

Coefficients (with 95% confidence bounds):

$$g = 1.379e+05 (-5.728e+04, 3.33e+05)$$

$$h = -0.00978 (-0.01444, -0.005117)$$

Where, is the modulus of elasticity, and T is temperature

The effect of temperature on properties of waxes and rubber are simulated using OpenModelica and results are discussed in the section-iii

III. RESULTS AND DISCUSSION

A. Shape Memory Cycle on Mixture of Inlay Wax and Rubber

The model for the mixture is given by figure 2.1 and equation 2.1, the modulus and viscosity of the components are function of Temperature given by equation 2.2 and 2.3

This model in differential equation form is simulated using OpenModelica for various steps of shape memory cycle to predict that this combination can behave as Shape Memory Polymers. The results for all the steps simulated in OpenModelica are as follows:

Step-I High Temperature Stretching

The Model is stretched at high temperature, i.e. above the melting temperature of wax 343 K at constant strain rate 0.001 sec⁻¹ for 1 sec. The stress strain curve is as shown in figure 3.1.

Initially due to viscosity of wax i.e. dashpot the strain generated is lower and then on application of constant strain rate this strain is taken up by spring so that the stress initially increases at low rate and varies linearly strain afterwards.

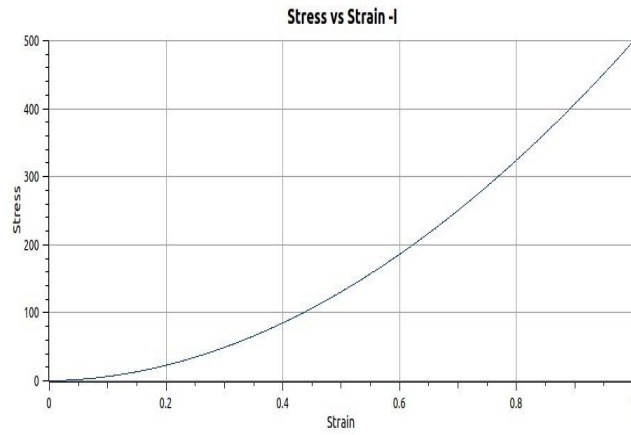

Figure 3.1 Stress Strain Curve

Step-II Cooling at Constant Strain

The Model is maintained at constant strain and temperature is lowered below the Melting temperature of wax. At this stage rubber stores the elastic energy. The stress required for maintaining a constant strain is more with decrease in temperature as shown in figure 3.5. The results are also plotted for the variation of Modulus and Viscosity Wax and Rubber shown in figure 3.2 to 3.5

The governing equations for model at this step is:

$$\sigma + \frac{\eta}{E} \dot{\sigma} = E_1 \quad (3.1)$$

As strain is maintained constant to 1 and which implies strain rate is zero.

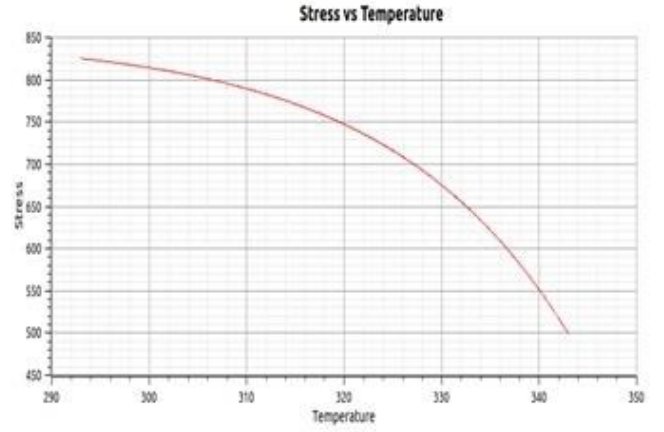

Figure 3.2 Stress Temperature curve for Mixture

Figure 3.2 shows the Stress and Temperature curve for step-ii. As the temperature is decreased while maintaining constant strain the spring representing the rubber remains at fixed position and tensile stress is acting simultaneously, on the other hand spring of the Maxwell element releases strain. Equilibrium requires that stress remains the same in both the elements of Maxwell model. Hence initially large stress is required to maintain the system in fixed strain. As the strain is released from the Maxwell element and taken by dashpot, then the stress strain curve varies linearly as per the spring representing rubber.

Figure 3.3 shows the effect of temperature on the elastic modulus of wax. As the temperature is increased the elastic modulus decreases, this is because of the fact that on increasing the temperature the mobility increases [15] and we have further seen in the literature that the modulus decreases exponentially with the temperature according to equation 2.2

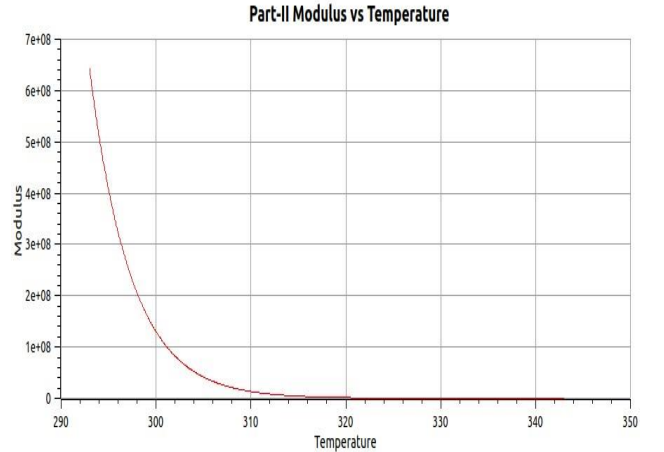

Figure 3.3 Modulus Temperature curve for Wax

Similarly the viscosity also decreases exponentially with temperature, figure 3.4 shows the behavior of viscosity of wax with temperature. As shown in figure there is an abrupt change in viscosity after the transition temperature. Due to this property of waxes these are often called as shape changing materials. The variation of viscosity of wax with temperature is given by equation 2.3

Part-II Viscosity vs Temperature for Wax

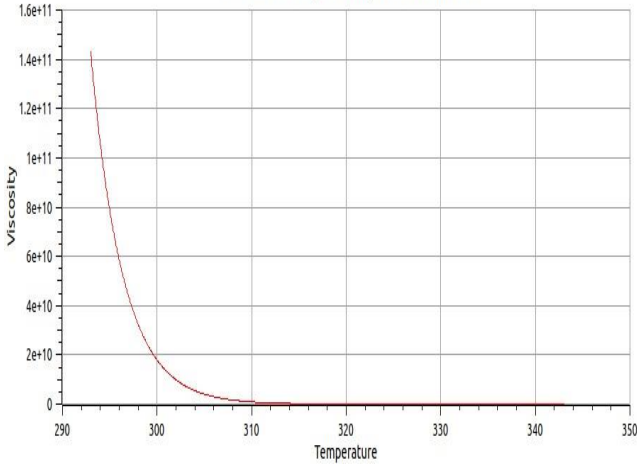

Figure 3.4 ViscosityTemperature curve for Wax

Rubber is completely elastic in nature, the modulus of rubber decreases with temperature according to equation 2.4. In our model of Wax and Rubber, rubber serves as the net points and responsible for the storage of elastic energy. On reversing the stimuli this stored elastic energy is released and responsible for the recovery of permanent shape. Wax on the other hand serves as switch segment which changes the shape on the application of stimuli. Due to these combined properties of variation of modulus and viscosity of rubber and wax respectively these material can serve as net points and switch segments in shape memory phenomena.

The simulation results of variation of modulus of rubber with temperature using OpenModelica is shown in figure 3.5

Part-II Modulus vs Temperature for Rubber

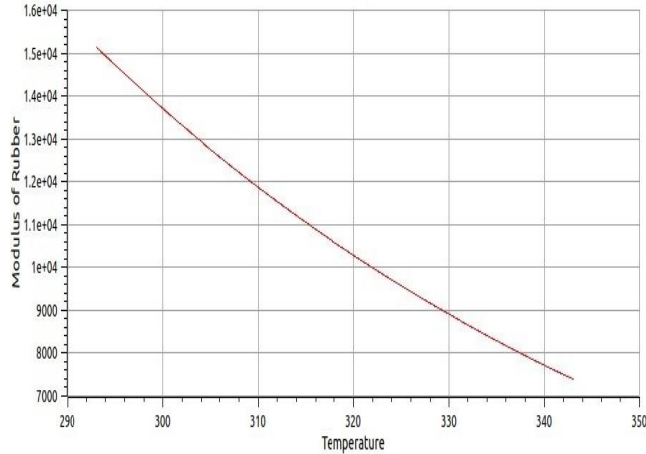

Figure 3.5 Modulus Temperature curve for Rubber

Step-III Stress Removal at Constant Low Temperature

Now the stress is gradually reduced to zero at a constant rate and small recovery is obtained. The governing equation of the model at this step is:

$$\sigma + \frac{\eta}{E} \dot{\sigma} = E_1 \varepsilon + \frac{\eta(E_1 + E_2)}{E_2} \dot{\varepsilon} \quad (3.2)$$

This is because now wax is crystallized and it offers resistance for the rubber to release its elastic energy and the tensile force of the rubber is balanced by the compressive force of the wax.

Thus, this new shape is stable temporary shape of the material which remains stable until it is again heated above the transition temperature of wax which acts as stimuli.

This step is the most crucial step in the shape memory cycle. As we seen that rubber releases all strain on removal of stress. And wax converts to a new permanent shape at this step. And the mixture of these two materials stores the strain energy at removal of stress and remains in a temporary stable shape as shown in figure 3.6

Part-III Stress vs Time

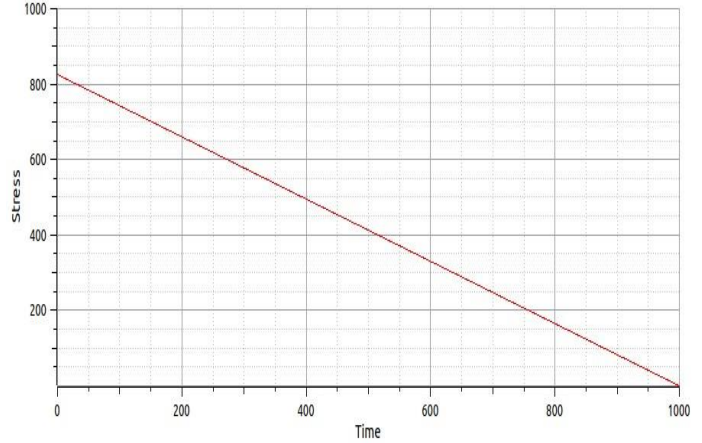

Figure 3.6 Removal of Stress

Step-IV Heating for Recovery

Again the model is heated above the melting temperature of wax and it shows recovery in shape due to release of stored elastic energy as wax no longer able to resist the rubber due to decrease in its modulus and viscosity. The governing equation at this step is:

$$E_1 \varepsilon + \frac{\eta(E_1 + E_2)}{E_2} \dot{\varepsilon} = 0 \quad (3.3)$$

This equation is solved by Euler's method in OpenModelica and we see that strain reduces to zero with increasing temperature.

The release of strain with increasing temperature is shown in figure 3.7

Part-IV Strain vs Temperature

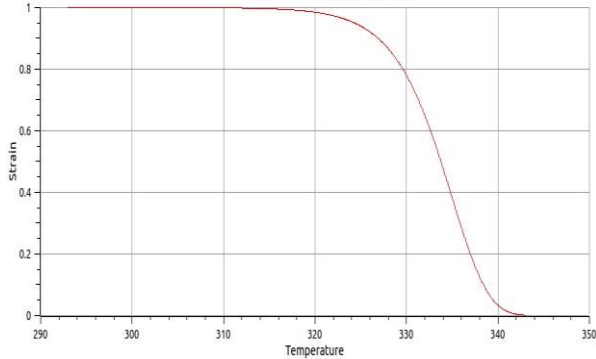

Figure 3.7 Heating for strain recovery

Figure 3.7 shows that after removal of stress in the step-iii the strain was still maintained and results in the temporary stable state, now the stimuli is again reversed i.e. the temperature is increased beyond the transition temperature and strain energy

stored is recovered and the material again comes to its original shape. Thus shape memory cycle is complete.

Complete Shape Memory Cycle of Mixture:

Combining all the steps into a 3-d curve for stress, strain and temperature we get the curve shown in figure 3.8. This curve is plotted using the results of OpenModelica for stress, strain and temperature of the mixture at every step of the shape memory cycle and plotted using Python script. . Figure 3.8 shows the complete cycle and predicts that our model behaves as shape memory polymer.

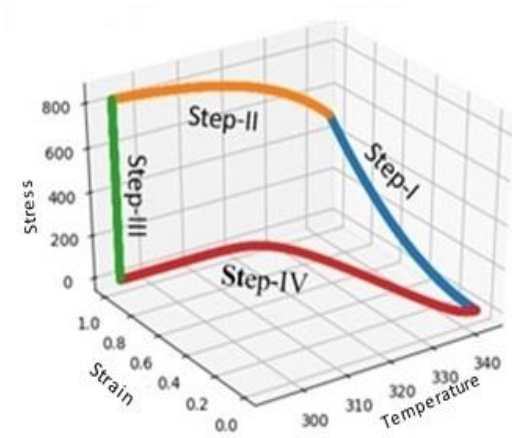

Figure 3.8 Combined shape memory cycle on mixture

B. Validation of OpenModelica Results with Experiments

The linear viscoelastic model for combination of wax and rubber when simulated in OpenModelica shows that this mixture behaves as shape memory polymers. To validate the prediction and simulation results experiments are performed using rubber and wax for all the steps.

Mixture of paraffin wax and rubber is prepared by heating both of them in an oven at around 520 K in a test-tube. The figure 3.9 shows the reference state of the material.



Figure 3.9 Reference state



Figure 3.10 Fixing of temporary shape

This material is now heated above the transition temperature and the shape is fixed using external stress as shown in figure 3.10

At step-iii, this material is now cooled to room temperature and deforming force is removed. Figure 3.11 shows the removal of stress and material exhibits temporary stable state



Figure 3.11 Removal of Stress

Further at step-iv this material is heated above the transition temperature in an oven. The oven temperature is maintained at 70°C and gradually shape is recovered. The final recovered shape is shown in figure 3.12



Figure 3.12 Final recovered shape.

Experimental Cycle:

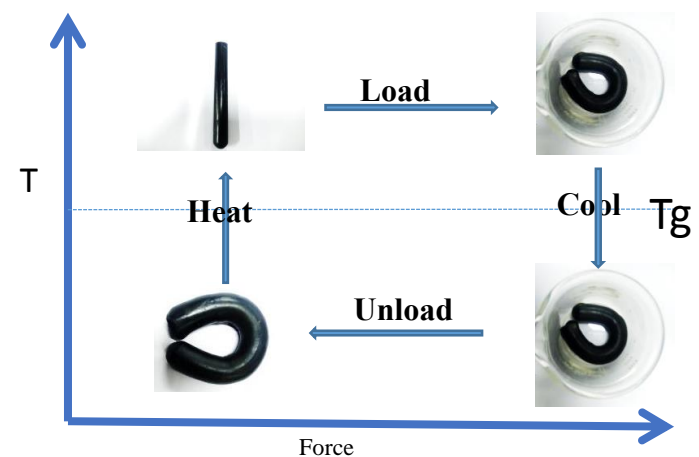

Figure 3.13 Shape Memory Cycle

IV. CONCLUSION

The simulation result of our viscoelastic model for rubber and wax mixture using OpenModelica exhibits shape memory phenomena, and is in good agreement with the trend of known shape memory polymers [17]. Also it is in good agreement with the experimental results. Our approach to develop shape memory materials using rubber and wax will enable to design a variety of shape memory materials and subsequently ensuring applications in diverse fields. Also, the OpenModelica code we have developed can be used to predict the shape memory behavior of any kind of material and stimuli which saves the time and resources.

REFERENCES

- [1] X. Wu, W. M. Huang, Y. Zhao, Z. Ding, C. Tang, and J. Zhang, "Mechanisms of the shape memory effect in polymeric materials," *Polymers (Basel)*, vol. 5, no. 4, pp. 1169–1202, 2013.
- [2] M. D. Hager, S. Bode, C. Weber, and U. S. Schubert, "Shape memory polymers : Past , present and future developments," *Prog. Polym. Sci.*, 2015.
- [3] K. Kim and S. Y. Lee, "Polyurethanes having shape memory effects," vol. 37, no. 26, pp. 5781–5793, 1996.
- [4] Y. Q. F. Huang, Wei Min, Bin Yang, "Polyurethane shape memory polymers," *CRC Press*, 2012, p. 383.
- [5] B. Dietch and T. Tong, "A review - : Features and benefits of shape memory polymers (SMPs)," *J. Adv. Mater.*, vol. 39, no. 2, pp. 3–12.
- [6] W. Small Iv, T. Wilson, W. Benett, J. Loge, and D. Maitland, "Laser-activated shape memory polymer intravascular thrombectomy device.," *Opt. Express*, vol. 13, no. 20, pp. 8204–8213, 2005
- [7] W. Small IV, P. R. Buckley, T. S. Wilson, W. J. Benett, J. Hartman, D. Saloner, and D. J. Maitland, "Shape memory polymer stent with expandable foam: A new concept for endovascular embolization of fusiform aneurysms," *IEEE Trans. Biomed. Eng.*, vol. 54, no. 6, pp. 1157–1160, 2007.
- [8] S. J. Garcia, "Effect of polymer architecture on the intrinsic self-healing character of polymers," *Eur. Polym. J.*, vol. 53, no. 1, pp. 118–125, 2014.
- [9] Q. Zhao, H. J. Qi, and T. Xie, "Recent progress in shape memory polymer: New behavior, enabling materials, and mechanistic understanding," *Prog. Polym. Sci.*, vol. 49–50, pp. 79–120, 2014.
- [10] J. R. L. and L. W. Chen, "The Mechanical-Vicoelastic Model and WLF Relationship in Shape Memorized Linear Ether-Type Polyurethanes," *J. Polym. Res.*, vol. 6, no. 1, pp. 35–40, 1999.
- [11] J. HU, "Shape memory polymers and textiles". Woodhead Publishing Limited, 2007.
- [12] F. Group, Shape-Memory Polymers and Multifunctional Composites
- [13] P. Ghosh and A. R. Srinivasa, "International Journal of Engineering Science A Two-network thermomechanical model of a shape memory polymer," *Int. J. Eng. Sci.*, vol. 49, no. 9, pp. 823–838, 2011.
- [14] J. W. Uwe Wolfmeier¹, Hans Schmidt (retired)², Franz-Leo Heinrichs³, Georg Michalczyk (retired)⁴, Wolfgang Payer⁵, Wolfram Dietsche⁶, Klaus Boehlke⁷, Gerd Hohner⁸, "Waxes," Ullman's Encyclopedia Of Industrial Chemistry. 2000.
- [15] R. G. Craig, J. D. Eick, F. A. Peyton, and K. Green, "Strength Properties of Waxes at Various Temperatures and Their Practical Application," *J. Dent. Res.*, vol. 46, no. 1, pp. 300–305, 1967.
- [16] P. Visakh, T. Sabu, K. C. Arup, and A. P. Mathew, *Advances in Elastomers I*, vol. 11. 2013.
- [17] Tobushi et al. , "Thermomechanical constitutive model of shape memory polymer", *Mechanics of Materials* 33 (2001) 545-554.

APPENDIX

OpenModelica Code

```

model NCCPS18

parameter Real T= 273+70"Temperature", Tg=200"Glass Transition Temperature",
a=1.015e+06, b=-0.01435, A=7.444e+37, B=-0.2284,X=8.366e+48,Y=-0.2968"Curve
Fitting Constants";

parameter Real h=0.001, dh=0.001"Step Change";
parameter Real epsdot=0.001"Strain Rate",dt=0.050"Step Change for
Temperature";

Real Q[1001]"Temperature or part-II",eta2[1001]"Viscosity for part-
II",E2[1001]"Modulus o Wax for part-II",M2[1001] "Modulus of Ruber for part-
II",y[1001]"Stress for Part-II",E"Modulus of Wax",eta"Viscosity of
Wax",M"Modulus of Rubber",eps[1001]"Strain for part-I",sigma[1001]"Stress
for part-I",epsilon[1001]"Srain for Part-II",stress[1001]"Stress for Part-
III",temp[1001]"Temperature for Part-III",STRAIN[1001]"Strain for PART-
III",eta3[1001]"Viscosoty of Wax for Part-III",E3[1001]"Modulus of Wax for
PART-III",M3[1001]"Modulus of Ruber for part-III",U[1001]"Temperature for
Part-III",S[1001]"Strain for PART-IV",STRESS[1001] "Stress for Part-IV",
Temperature[1001]"Temperature for Part-IV";

equation
/* Part-I High Temperature Stretching*/

for i in 1:1001 loop
Temperature[i]=343;
end for;

for c in 1:1001 loop
epsilon[c]=eps[1001];
end for;

Q[1]=T;
for j in 1:1000 loop
Q[j+1]=Q[j]-dt;
end for;

eta=X*exp(Y*T);
eta2[1]=eta;
for k in 1:1000 loop
eta2[k+1]=(X*exp(Y*Q[k+1]));
end for;

E=A*exp(B*T);
E2[1]=E;
for l in 1:1000 loop
E2[l+1]=A*exp(B*Q[l+1]);
end for;

M= a*exp(b*T);
M2[1]=M;
for n in 1:1000 loop
M2[n+1]=a*exp(b*Q[n+1]);

```



```

end for;

eps[1]=0;
for i in 1: 1000 loop
eps[i+1]=eps[i]+dh;
end for;

sigma[1]=0;
for i in 1:1000 loop

sigma[i+1]=sigma[i]+(E/eta)*h*((M*eps[i])+(eta*epsdot*((M+E)/E))-sigma[i]);
end for;

/*Part-II Cooling at Constant Strain*/
y[1]=sigma[1001];
for i in 1:1000 loop
y[i+1]=y[i]+h*((M2[i]*eps[1001])-y[i])*(E2[i]/eta2[i]);
end for;

/*Part-III Stress Removal at Constant Low Temperature*/
stress[1]=y[1001];
for d in 1:1000 loop
stress[d+1]=stress[d]-(y[1001]/1000);
end for;
//stress[1000]=0;

for e in 1:1001 loop
temp[e]=Q[1001];
end for;

STRAIN[1]=1;
for f in 1:1000 loop
STRAIN[f+1]=STRAIN[f]+h*(stress[f]+(eta2[1001]/E2[1001])*(y[1001]/1000)-
(M2[1001]*STRAIN[f]))*(E2[1001]/((M2[1001]+E2[1001])*eta2[1001]));
end for;

/*Part-IV Heating for Recovery*/
U[1]=Q[1001];
for g in 1:1000 loop
U[g+1]=U[g]+dt;
end for;

eta3[1]=eta2[1001];
for p in 1:1000 loop
eta3[p+1]=X*exp(Y*U[p+1]);
end for;

E3[1]=E2[1001];
for r in 1:1000 loop
E3[r+1]=( A*exp(B*U[r+1]));
end for;

M3[1]=M2[1001];
for s in 1:1000 loop
M3[s+1]=a*exp(b*U[s+1]);
end for;

```

```
S[1]=STRAIN[1001];
for H in 1:1000 loop
S[H+1]=S[H]+1*(-(E3[H]*M3[H]*S[H])/((M3[H]+E3[H])*eta3[H]));
end for;

for w in 1:1001 loop
STRESS[w]=stress[1001];
end for;

end NCCPS18;
```

Production of aniline by hydrogenation of nitrobenzene

Anusha Halageri

Department of Chemical Engineering
Ramaiah Institute of Technology
Bangalore, India
anuhalageri@gmail.com

Glen Pauls

Department of Chemical Engineering
Ramaiah Institute of Technology
Bangalore, India
glenpaul410@gmail.com

Ananya Srivastava

Department of Chemical Engineering
Ramaiah Institute of Technology
Bangalore, India
ananyasrivastava1298@gmail.com

Abstract—Aniline, an important compound in organic chemistry, is mainly used to synthesize polyurethane and its precursors. Being one of the most important industrial chemicals, it is used to produce other industrial chemicals like methylene diphenyl diisocyanate (MDI), cyclohexylamine, benzoquinone, alkyl anilines, methylene dianiline etc. In this study, production of aniline at 10 tons/h was done by reducing nitrobenzene using hydrogen and this process was simulated using DWSIM open source software. The operating conditions of the different unit operations for this simulation were selected to achieve 75 percent conversion of nitrobenzene to aniline. Heat integrations were done by heating the reactants with the heat liberated from reactor. The property packages used were Lee-Kesler-Plöcker and NRTL models. Sensitivity analysis was performed on three of the main units used in the process i.e. on the cooler, heat exchanger and distillation column.

Keywords—Nitrobenzene, Aniline, Hydrogenation, Sensitivity Analysis, Rigorous Distillation

I. INTRODUCTION

Aniline is an organic compound consisting of a phenyl group attached to an amino group, where aniline is the prototypical aromatic amine. The amino group provides unique reactivity which makes it an industrially important intermediate. [1] It is a flammable liquid chemical and is slightly soluble in water. It is also known as phenylamine or aminobenzene.

Its main applications are in the production of herbicides, dyes, explosives, pigments, pesticides, plastics (polyurethanes) where aniline acts as an important intermediate. In the field of pharmaceuticals, paracetamol (acetaminophen), a widely used antipyretic is also prepared from aniline. [2,3] Polyaniline, an intrinsically conducting polymer is also produced from aniline.

Aniline is formed by the reduction of nitrobenzene using hydrogen. This process was proposed by Haber and his initial scheme was published in 1898. The scheme proposed that the transformation of nitrobenzene to aniline is a three-step process in which the intermediates nitrosobenzene and phenylhydroxylamine are formed. In addition to this, it was suggested that the by-products azobenzene, azoxybenzene, and hydrazobenzene could be formed via a side reaction of the above intermediate species. Hydrogenation can also be done using a catalyst to enhance the rate of reaction but the transformation is extremely superficial and needs to

be done under relatively mild conditions. [4] However, in this paper, the side reactions and formation of intermediates have been neglected. Hence, simulation has been performed accordingly. These assumptions were made due to lack of literature or existing papers available for the simulation of the process. Basic knowledge from scientific papers was taken into consideration to create the DWSIM flowsheet and simulation.

The non-random two-liquid model (NRTL) is an activity coefficient model used to calculate phase equilibria and mainly applied for processes involving polar compounds. In this process, there are 3 polar chemicals, namely, nitrobenzene, aniline and water. Hence, the NRTL property package was selected. Lee-Kesler-Plöcker (LKP) model is applied for systems with high Hydrogen content. Since the production of aniline is done by hydrogenation of nitrobenzene it was necessary to apply this property package.

II. PROCESS DESCRIPTION

The main process for aniline production is hydrogenation of nitrobenzene, given by the reaction equation:

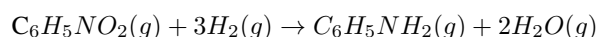

The process flowsheet designed for the production of aniline from nitrobenzene and hydrogen is shown in Fig.1.

Nitrobenzene (MSTR-NB) at room temperature of 24°C is sent to a heat exchanger (HE-1) where it is heated to 214.93°C. The heated nitrobenzene (MSTR-NB1) is then sent to the heater (HEAT-1) and further heated to 450°C. Gaseous nitrobenzene (MSTR-NB2) gets mixed with gaseous hydrogen (MSTR-H2) in a mixer (MIX-1). This reactants mixture stream (MSTR-1) is sent to the conversion reactor (RCTR) where the reaction takes place at 330°C. [5]

Standard Gibbs free energy was calculated using enthalpy and entropy data from the literature for every compound. Further, the reaction's equilibrium constant was found and equilibrium conversion was calculated. For this process, an approximate of 75 percent conversion with respect to nitrobenzene was obtained. This value was entered in the conversion reactor (RCTR) to obtain the desired yield of aniline.

The heat of reaction from the reactor is used to heat the feed nitrobenzene in the heat exchanger (HE-1). After heat

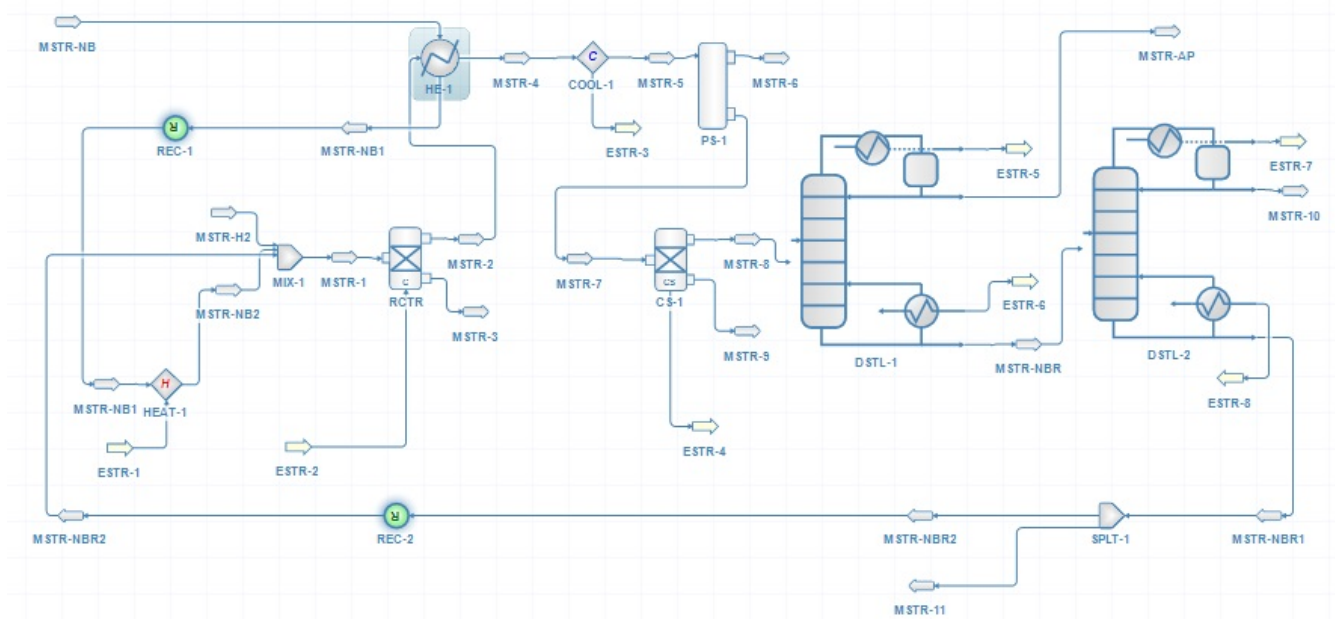

Fig. 1. DWSIM flow sheet

exchange the mixture is at 163°C and is now sent to a cooler (COOL-1) to further reduce its temperature to 50°C. The cooled mixture (MSTR-5) contains only hydrogen in the vapor phase which is removed using a phase separator (PS-1). The liquid stream (MSTR-7) from the phase separator is sent to a compound separator (CS-1) (which has been assumed to be a decanter) where water is completely separated from the organic mixture.

This organic mixture of nitrobenzene and aniline (MSTR-8) is sent to a distillation column (DSTL) to separate aniline and nitrobenzene based on their boiling points. Rigorous distillation column model of DWSIM has been used to simulate the distillation column. The preliminary data required for the rigorous distillation column (DSTL-1) was generated using a short cut distillation column assuming the top product composition (MSTR-AP) to be 98.1 percent aniline.

Nitrobenzene coming in the residue (MSTR-NBR) consists of traces of aniline which is further purified using another distillation column (DSTL-2). The recovered nitrobenzene stream (MSTR-NBR1) is recycled and a part of the recycle stream is purged.

III. RESULTS AND DISCUSSION

The simulation results of main streams in the process, i.e. of the reactor and distillation column-1 are given below.

As shown in table 1, it was observed that at a temperature and pressure of 311.17°C and 1.4 bar, the product stream from reactor contained aniline in large quantity of around 11 tons/h. Even though large amount of aniline was produced, it was a diluted stream with mole fraction of about 0.246. Its purity was improved using two distillation columns.

Since aniline is more volatile than nitrobenzene, it was obtained as distillate product from distillation column 1 (refer first half of table 2). The less volatile component, nitrobenzene, was observed in residue with a mole fraction of about 0.843 (refer second half of table 2) which is further purified in distillation column 2. Again in the other distillation column, nitrobenzene was obtained as residue product which could be reused again by recycling. To avoid accumulation of reactants, a part of the recycled stream was removed as purge.

TABLE I
Products from reactor

Species	Mass Flows (kg/h)	Mole Fraction
Aniline	11482	0.246
Water	4411.99	0.488
Nitrobenzene	4936.18	0.08
Hydrogen	187.11	0.185

TABLE II
Products from distillation column 1 (Distillate and Residue)

Species	Mass Flows (kg/h)	Mole Fraction
Aniline	10818.11	0.981
Nitrobenzene	273.57	0.018
Aniline	653.96	0.156
Nitrobenzene	4659.29	0.843

COOL-1 - Outlet Temperature (C)	MSTR-5 - Mass Flow (Vapor Phase) / Aniline (kg/h)	MSTR-5 - Mass Flow (Vapor Phase) / Nitrobenzene (kg/h)	MSTR-5 - Mass Flow (Vapor Phase) / Water (kg/h)	MSTR-5 - Mass Flow (Vapor Phase) / Hydrogen (kg/h)
50	13.1149	2.46115	154.058	233.823
60	24.78	4.85046	259.659	233.823
70	46.4779	9.44285	430.993	233.826
80	88.3566	18.5348	710.197	233.83
90	174.712	37.6299	1161.59	233.837
100	363.419	80.0889	1824.76	233.853
110	751.645	170.721	2554.72	233.886
120	1427.3	341.353	3124.22	234.153
130	2467.83	640.038	3505.41	234.691
140	3981.58	1160.25	3753.12	236.604
150	6114.87	2093.97	3894.06	243.405

Fig. 2. Sensitivity Analysis Table for Cooler

A. Sensitivity Analysis for Cooler

Hydrogenation of nitrobenzene to aniline is an exothermic reaction occurring at 330°C. The reactor product stream contains aniline, water and unreacted reactants nitrobenzene, hydrogen. After being sent to the heat exchanger, the products attain a temperature of 163.69°C. They were further cooled by the cooler to facilitate the formation of two phases. The vapor phase after cooling mainly consisted of unreacted hydrogen which was separated using a gas-liquid separator. In order to determine the temperature at which maximum phase separation occurs, a sensitivity analysis was performed on the coolers output stream (MSTR-5). Change in mass flow of each of the species, in vapor phase, was studied for a temperature range of 50°C to 150°C. The tabulated and graphical results are shown in Fig. 2 and Fig. 3 respectively. At 50°C, aniline was

cooled to 50°C to separate the unreacted hydrogen. The water present along with the aniline and nitrobenzene forms a two phase liquid mixture which could be separated using a decanter.

B. Effect of reflux ratio

For the Distillation Column (DSTL-1), where a mixture of aniline and nitrobenzene (MSTR-8) is separated, sensitivity analysis was done by varying the reflux ratio from 1 to 6 and its effect on condenser duty, distillate molar flow, reboiler duty and number of stages was analyzed. However, no effect on any of the above parameters was observed by the software (refer Fig.4). Hence, a manual analysis was performed by changing the number of stages and noting the effect on the distillate and residue compositions. These results have been mentioned below in Table 3.

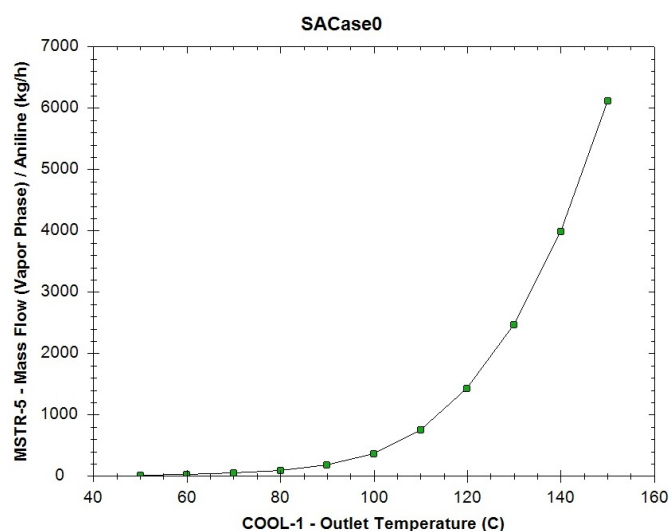

Fig. 3. Sensitivity Analysis Chart for Cooler

completely in liquid in liquid phase. Hence the reactor product

DSTL-1 - Reflux Ratio	DSTL-1 - Condenser Duty (kW)	DSTL-1 - Distillate Molar Flow (kmol/h)	DSTL-1 - Reboiler Duty (kW)	DSTL-1 - Number of Stages ()
1	8700.12	118.386	-10038.1	10
2.25	8700.12	118.386	-10038.1	10
3.5	8700.12	118.386	-10038.1	10
4.75	8700.12	118.386	-10038.1	10
6	8700.12	118.386	-10038.1	10

Fig. 4. Sensitivity Analysis Table for Distillation Column 1

TABLE III

Analysis on upstream and downstream aniline composition (Mole fractions)

No. of stages	Upstream	Downstream
8	0.95	0.24
9	0.97	0.18
10	0.98	0.16

C. Sensitivity Analysis for Heat Exchanger

Sensitivity analysis was performed on the heat exchanger (HE-1). Here, the hot fluid outlet temperature (i.e. MSTR-4, containing reaction mixture) was varied from 50°C to 170°C

and its effect on cold fluid outlet temperature (i.e. MSTR-NB1, containing nitrobenzene) was recorded. No variation was shown by the software (refer fig.5). However, when the analysis was done manually by inputting the values of heat to be exchanged between the two fluids (in calculation parameters section), the results were obtained as shown in Table 4 and it can be concluded that as the amount of heat exchanged between the fluids increases the cold fluid outlet temperature increases and that of hot fluid decreases.

Results	
HE-1 - Hot fluid outlet temperature (C)	HE-1 - Cold fluid outlet temperature (C)
50	214.943
60.9091	214.943
71.8182	214.943
82.7273	214.943
93.6364	214.943
104.545	214.943
115.455	214.943
126.364	214.943
137.273	214.943
148.182	214.943
159.091	214.943
170	214.943

Fig. 5. Sensitivity Analysis Table for Heat Exchanger

TABLE IV

Analysis on Cold and Hot fluid outlet temperatures

Heat exchanged (kW)	Cold Fluid Outlet temperature (°C)	Hot Fluid Outlet temperature (°C)
1000	132.22	224.26
1500	181.83	178.11
2000	224.04	162.04
2500	224.05	156.20
3000	224.05	149.51
4000	237.33	133.34

IV. CONCLUSION

Process simulation for the production of aniline by reduction of nitrobenzene was done using DWSIM. The various thermodynamic data were entered for each unit operation after thorough research and calculation for its feasibility. The simulation yielded good results providing with better knowledge relating the thermodynamics and kinetics of the reaction. Number of separation units were included based on the different separation principles to obtain considerable purity of the final aniline product. Sensitivity analysis was performed on the cooler and it showed that as the outlet temperature of the cooler increases, mass flow of aniline in vapor phase also increases. Hence, lower temperature condition is preferred in order to get higher mass flow of liquid aniline which is the desired product.

While working with DWSIM, the team felt that the sensitivity analysis parameters could be improved i.e. more number of dependent and independent variable combinations could be

added in the software, because, even after trying to perform different types of analysis on the process, the desired results were not obtained from the software. It was possible only after manually changing the specifications of the unit. Also, the software could include other objects like decanter, crystalliser, extractor, dryer etc. to improve the simulation and flowsheet design.

V. ACKNOWLEDGMENT

We would like to extend our hearty gratitude to Dr. Archana, Head of Department of Chemical Engineering, Ramaiah Institute of Technology, for giving us the opportunity to work on this project. We would also like to thank our professors Dr. Mahendra Chintala, Mrs. Sravanthi Veluturla and Mr. Neelesh Singhal, for their kind guidance and help throughout the making of this paper and also in designing the simulation process.

REFERENCES

- [1] M. Turakova, T. Salmi, K. Eranen, J. Warna, D.Yu. Murzin, M. Kralik, Liquid phase hydrogenation of nitrobenzene, Applied Catalysis A, General, 2015.
- [2] M. Kulkarni, A. Chaudhari, Microbial remediation of nitro-aromatic compounds: An overview, Journal of Environmental Management. 85, 496–512, 2007.
- [3] L. Fu, W. Cai, A. Wang, Y. Zheng, Photocatalytic hydrogenation of nitrobenzene to aniline over tungsten oxide-silver nanowires, Materials Letters. 142, 201–203, 2015.
- [4] Gelder E.A., Jackson S.D., Lok C.M., The hydrogenation of nitrobenzene to aniline: a new mechanism, 2004.
- [5] Y. Jiang, X. Li, Z. Qin, H. Ji, Preparation of Ni/bentonite catalyst and its applications in the hydrogenation of nitrobenzene to aniline, Chinese Journal of Chemical Engineering 24, 1195-1200, 2016.
- [6] Perry, Robert H., "Perry's Chemical Engineers' Handbook," 7th edition, McGraw-Hill publications, 1997.
- [7] Shreve, R. Norris, "The Chemical Process Industries," 2nd edition, Chapter 38, 867-874, McGraw-Hill publications, 1956.
- [8] Groggins, P.H., "Unit Processes in Organic Synthesis," 5th edition, Chapters 4 and 5, 150-161, 168-183, McGraw-Hill publications, 1958.

Chlorination of Benzene

Gowri Shankar K

Department of Chemical Engineering
Ramaiah Institute of Technology
Bangalore, India
gowrishankar1177@gmail.com

Rajat Subramanian

Department of Chemical Engineering
Ramaiah Institute of Technology
Bangalore, India
rajatsubramanian1998@gmail.com

Sravanthi V

Department of Chemical Engineering
Ramaiah Institute of Technology
Bangalore, India
sravanthi.v@msrit.edu

Abstract—One of the most important processes in several industries is the large-scale production of C_6H_5Cl . It is widely used as an intermediate for the production of herbicides, pesticides, dyes and rubbers. It is also used as a high boiling solvent in industrial synthesis as well as in laboratories. In dye industry, it is used for indigo production. This paper highlights the simulation of monochlorobenzene synthesis using the open source DWSIM software, with benzene and chlorine as the reactants. The main product obtained from the reaction was monochlorobenzene, with the formation of HCl as the by-product. The Soave Redlich Kwong (SRK) and Chao seader methods were used as the basis for the calculation of output streams for the conversion reactor and distillation column respectively. Also, cooler, heater and gas liquid separator have been used as the other components in this process. The maximum conversion percentage of benzene was 55 percent which agrees with thermodynamic calculations. The parameters optimized using DWSIM were the number of stages in distillation, re-flux ratio, product recovery in the condenser and product molar flow in re-boiler. It was possible to obtain a pure yield of about 92 mass percent of monochlorobenzene from the output stream of the process.

Keywords—Benzene, Chlorine, Monochlorobenzene, DWSIM, Simulation, Recycle.

I. INTRODUCTION

Monochlorobenzene is an aromatic compound. It is a colourless and flammable liquid [1] which is widely used as an intermediate for the manufacture of other chemicals like herbicides, dye-stuffs, and rubber [2]. It is also used as a high-boiling solvent for various industrial applications as well as in the laboratory. It is nitrated on a large scale to give a mixture of 2-nitrochlorobenzene and 4-nitrochlorobenzene, which are separated and converted into nitrophenol, nitroanisole and nitroaniline by nucleophilic displacement of the chloride ion [3]. Main intermediate to produce phenol is monochlorobenzene [4].

It was first found in 1851. It is manufactured by chlorination of benzene in the presence of a catalytic amount of Lewis acid such as ferric chloride, sulphur dichloride and anhydrous aluminum chloride.

The catalyst used in this reaction is $AlCl_3$, which does not alter the conversion of reactant, but helps in increasing the speed of the reaction. This catalyst is also used to enhance the electrophilicity of chlorine, as chlorine is electronegative and

C_6H_5Cl has decreased susceptibility to further chlorination. Industrially, the reaction is conducted as a continuous process to minimize the formation of dichlorobenzenes, which is an unwanted product [3]. The reactor temperature is kept similar to the room temperature.

II. THE PROCESS

A. Theory

The reaction is first carried out in a conversion reactor at a temperature of around 25 degrees Celsius. There are two feed streams - chlorine and benzene. Chlorine enters the reactor in gaseous phase while benzene enters in liquid phase, at room temperature. The feed is taken at 29 degrees Celsius as maximum conversion of benzene into monochlorobenzene happens at this temperature of the feed.

The reactor temperature and conversion of benzene is kept low to prevent the formation of the undesired higher chlorinated benzene. Un-reacted chlorine, hydrogen chloride and catalyst is then removed from the product stream with the help of a stripper. The product stream is then passed through a distillation column to obtain it in its purest form.

The direct split distillation method is used since it is desired to reduce the number of distillate columns. This would make the production of monochlorobenzene more economical and hence, lower the operating cost.

B. Description of the Simulation

Modelling and simulation of the production of monochlorobenzene using the open source DWSIM software version 5.2 was done. The following assumptions were made:

- The conversion ratio that is fed to the reactor is that which is obtained if the reaction is catalyzed by Aluminum Chloride.
- The cooler is used in place of a condenser for cooling the material streams.

Benzene, chlorine, monochlorobenzene, and water were taken as the components in this simulation. SRK and Chao Seader methods were chosen as the basis for solving the flow sheet as shown in the Fig. 1.

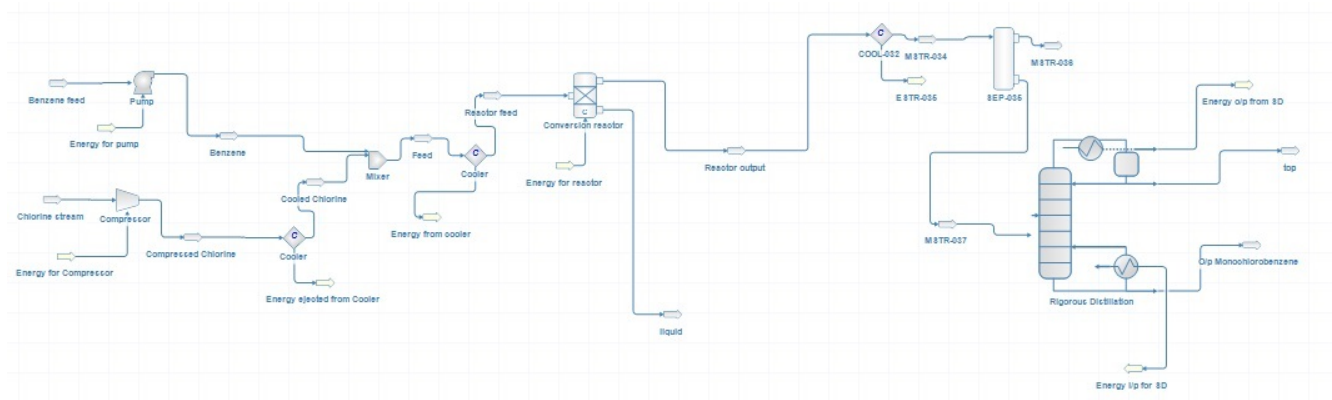
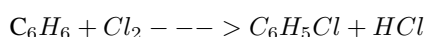

Fig. 1. DWSIM SIMULATION OF CHLORINATION OF BENZENE

First, two input streams- benzene and chlorine were taken. Benzene had a molar flow rate of 200 kmol/hr, pressure of one atmosphere and was at room temperature. It was then passed through a pump, out of which a benzene stream at 2.4 bar pressure is obtained - this is the optimum pressure for the reaction to take place in the reactor. Chlorine gas was passed through the other input stream at a molar flow rate of 200 kmol/hr, pressure of one atmosphere and was kept at room temperature. It was then compressed with the help of a single stage compressor to 2.4 bars.

A mixer was used for mixing the two feed streams and the mixture was then cooled to 29 degrees Celsius with the help of a cooler. It was then passed through a conversion reactor. The Soave Redlich Kwong Method was used as the basis for the calculation of the output stream.

The reaction taking place in the reactor is as follows:



The main catalyst used was either aluminum chloride or iron chloride. The conversion percentage was defined as 55 percent which agreed with the theoretical calculations.

The reactor output stream was then cooled to 70 degrees Celsius with the help of a cooler and it was then passed through a gas-liquid separator from which the liquid stream was separated and passed to a rigorous distillation column. The Chao Seader method was used as the basis for the calculation of the output streams in the distillation column. It was used to separate the un-reacted benzene and monochlorobenzene. The light key and heavy key components were selected as benzene and monochlorobenzene respectively and a minimum reflux ratio was set to 1.5. It was operated at a median temperature of benzene and monochlorobenzene for separation. It was observed that about 92 percent of the bottom stream comprised of monochlorobenzene.

III. RESULTS AND DISCUSSION

PARAMETERS	Reactor output	Distill TOP	Distill BOTTOM
DWSIM			
Temperature(Celsius)	100.051	18.475	122.803
Pressure(bar)	1.4	1	1.1
Mass flow(kg/hr)	29548.5	3843.01	7843.33
Volumetric flow(m ³ /hr)	8685.44	4.6487	72.7411
Amount of C6H5CL(kg/hr)	9216.348	3498.4672	670.68
Amount of C6H6(kg/hr)	8759.668	21.468	7163.396
ASPEN			
Temperature(Celsius)	103.051	16.475	118.803
pressure(bar)	1.4	1	1.1
Mass flow(kg/hr)	29678.5	3896.01	7850.33
Volumetric flow(m ³ /hr)	8850.44	4.987	70.7411
Amount of C6H5CL(kg/hr)	9190.348	3406.4672	640.68
Amount of C6H6(kg/hr)	8790.668	21.850	7190.789

A. REACTOR OUTPUT

The reaction between benzene and chlorine took place in a conversion reactor. The reactor feed was kept at temperature of 29 degrees Celsius and the conversion percentage was defined as 55 percent. The pressure drop in the reactor was kept as 1 bar. Benzene and chlorobenzene were the major products obtained along with traces of hydrogen chloride and water.

B. DISTILLATION OUTPUT

The reactor output stream was then sent to the rigorous distillation column. The number of stages in it was set to 8, with the feed tray located in stage 5. In this column, since benzene was the light key component, it is obtained in the upper distillate stream as the main product. On the other hand, about 92 percent of monochlorobenzene was obtained in the bottom stream along with traces of benzene and water.

IV. VALIDATION OF RESULTS

Aspen Plus v10 was used for the validation of results. The flow sheet is shown in Fig.2. The input streams benzene and chlorine streams were fed at the same conditions as in DWSIM. The pressure of the benzene stream was increased to 2.4 bar using a pump. The pressure of Chlorine was elevated to 2.4 bar using a single stage compressor. These two streams were then mixed using a mixer, it was then cooled to 29 degrees before being fed to the stoichiometric reactor. The Soave Redlich Kwong (SRK) method was used for the calculation of the output reactor stream. It was noted that maximum conversion occurred at this temperature. It was then cooled to 70 degrees and was then passed into a gas liquid separator from which the liquid stream was isolated and fed into a rigorous distillation column. Here, the light key component was benzene and monochlorobenzene was the heavy key component. The number of stages in the distillation column was set to 8 and the feed tray location was at 5th stage. The reflux ratio was set to 1.5. The Chao Seader method was used for calculation of the top and bottom distillates. The top distillate mainly consisted of benzene and the bottom distillate was composed of monochlorobenzene.

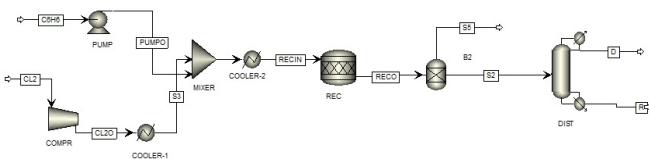

Fig. 2. CHLORINATION OF BENZENE USING ASPEN

V. SENSITIVITY ANALYSIS

The method by which determination of how an independent variable value will affect a particular dependent variable under the prevailing set of conditions, taking into account the assumptions, is defined as sensitivity analysis. Here, sensitivity analysis for the rigorous distillation Column was done.

For this, reflux ratio of the rigorous distillation column was taken as the independent variable. Reflux ratio is defined as the ratio of the amount of reflux in bottom distillate to that of the top distillate.

A. Condenser Duty

The first graph shows the variation of Condenser Duty of rigorous distillation column with varying reflux ratio. The lower limit of the reflux ratio was set at 1 and 10 was the upper limit. The graph is plotted and straight line with negative slope is obtained. The graph shows that there is decrease in condenser duty with the increase in reflux ratio. This means that less energy is ejected from the distillation column if the reflux ratio increases.

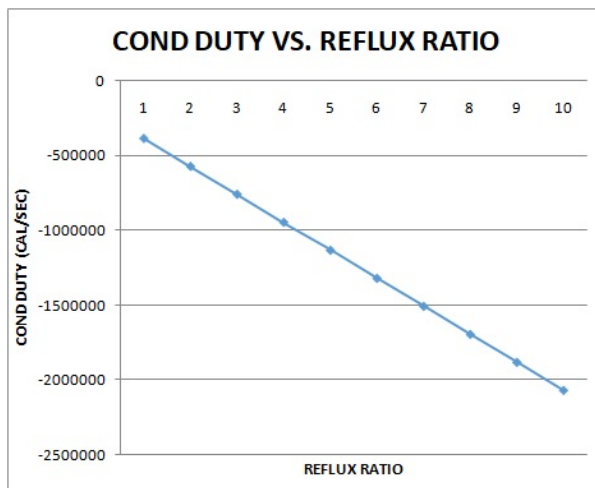

Fig. 3. Variation of Condenser Duty with Reflux Ratio

B. Reboiler Duty

The second graph shows the variation of re-boiler duty with reflux ratio. The lower limit of reflux ratio is 1 and the upper limit is 10. Reboiler duty is the amount of energy required to run the distillation column. The graph was then plotted and a straight line with positive slope was observed. It was observed that the reboiler duty increases with the increase in reflux ratio. This signifies that more energy is required for operating the distillation column if there is higher reflux ratio.

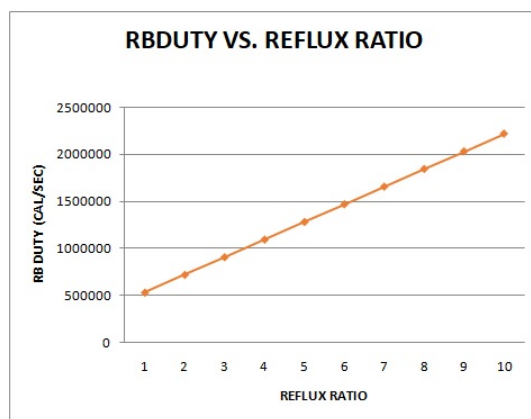

Fig. 4. Variation of Reboiler Duty with Reflux Ratio

VI. THE METHOD AND ITS ADVANTAGES

Direct method for the chlorination of benzene has been prescribed in this simulation. In this method, equal amounts of benzene and chlorine were reacted to form the main product as monochlorobenzene with hydrogen chloride also being formed as the by product. The reaction occurred in mixed phase with

benzene in liquid phase and chlorine in vapour phase. It was preferred over other methods as it is simple to use and easily understandable. It is also highly economical and did not contain a lot of process equipments. Hence, it is easy to maintain them. This reduces the maintenance cost. It also increases the efficiency of the entire process. It also gives the maximum conversion of benzene to monochlorobenzene which can be easily purified into a pure form using only one distillation column.

VII. LIMITATIONS

a) There is no catalytic reactor to input properties of the catalyst.

b) Condensers or similar equipments are unavailable.

VIII. CONCLUSION AND FUTURE WORK

The simulation for the chlorination of benzene was done with DWSIM and the validation of the results from DWSIM was done with the help of a similar simulation done using Aspen Plus. The conversion of monochlorobenzene from the conversion reactor was defined to be around 55 percent. This is similar to the conversion of monochlorobenzene calculated theoretically. In terms of improving this method, the neutralizer can be replaced by an absorber. This simulation was performed by adopting direct chlorination method. Other methods for benzene chlorination can also be attempted.

ACKNOWLEDGMENT

We would like to thank the professors of the Department of Chemical Engineering of Ramaiah Institute of Technology, Bangalore for their support and guidance.

REFERENCES

- [1] U. Beck, E. Lser, Chlorinated Benzenes and other Nucleus-Chlorinated Aromatic Hydrocarbons, Ullmanns Encyclopedia of Industrial Chemistry, vol.8, pp.483-514, 2011.
- [2] Gerald Booth, "Nitro Compounds, Aromatic," Ullmann's Encyclopedia of Industrial Chemistry, Weinheim: Wiley-VCH, vol.24, pp.316-320, 2007.
- [3] M. Weber, Weber, Markus, Kleine-Boymann, Michael "Phenol," Ullmann's Encyclopedia of Industrial Chemistry. vol.26, pp.511-513, 2004.
- [4] D. Jeffery, A. Duncan, F. Michael. "Benzene Chlorination Case Study, Ind. Eng. Chem. Res., vol.43, pp.3970-3971, 2004.
- [5] A.C. Kokossis, C.A. Floudas, "Synthesis of Isothermal Reactor-Separator-Recycle Systems," Chem. Eng. Sci. vol.46, pp.1361-1383, 1991.
- [6] B. Silberstein, H. Bliss, J.J.B. Butt, "Chlorination of Benzene with Stannic Chloride Catalyst," Ind. Chem. Eng. Ind. Chem. Eng. vol.8(3), pp.365-374, 1969.

Production of ethyl chloride from ethylene and hydrogen chloride involving recycle stream

Manaswini Gowtham V

Department of Chemical Engineering
Ramaiah Institute of Technology
Bangalore, India
manaswinigowthamv@gmail.com

Sneha S

Department of Chemical Engineering
Ramaiah Institute of Technology
Bangalore, India
snehashivanathan137@gmail.com

M Sunaina Poonacha

Department of Chemical Engineering
Ramaiah Institute of Technology
Bangalore, India
sunaina.poonacha@yahoo.co.in

Abstract—Ethyl chloride is one of the most important prerequisites for the manufacture of various organic compounds. The synthesis of ethyl chloride from ethylene and hydrogen chloride by direct chlorination is considered to be one of the most preferred and economical methods of production. A continuous production of nearly 3 tons/hour of ethyl chloride from hydrogen chloride and ethylene was simulated using the open source chemical process simulator, DWSIM. The results obtained from the DWSIM simulation was compared with the results of the same process executed on the commercial chemical process simulator, ASPEN PLUS v10. Different reactor configurations were also studied and the results were found to be comparable. From the simulation results obtained on ASPEN PLUS and DWSIM, the production of ethyl chloride using an equilibrium reactor also increased slightly.

Keywords—Ethyl chloride, Chlorination, Recycle, DWSIM, ASPEN PLUS.

I. INTRODUCTION

Chloroethane, better known as ethyl chloride, is used in the production of tetraethyl lead, a gasoline additive. It is a colourless, flammable gas or refrigerated liquid, mainly employed as a chemical intermediate in solvents, aerosols, and anaesthesia. It is used as a blowing agent in foamed plastics, in the production of ethyl cellulose and acts as an ethylating agent in the manufacture of dyes, chemicals and pharmaceuticals. Earlier it was formed as a by product in vinyl chloride synthesis but presently it is exclusively manufactured for a number of applications [1].

Ethyl chloride is produced by the gas phase reaction of hydrogen chloride with ethylene over a metal chloride catalyst. It can also be synthesized by the chlorination of ethane in the presence of heat or radiant energy. However, this method of production, using ethane, poses many disadvantages. It is not only quite expensive, but also gives a mixture of chlorinated hydrocarbons alongside ethyl chloride, introducing the added cost of separation and a poor yield of product.

The gas phase reaction of ethylene with hydrogen chloride to form chloroethane is an addition reaction. It proceeds with almost no by-products or side reactions and it has a high selectivity for the monochlorinated product (chloroethane). The chemical reaction is represented by the following equation:

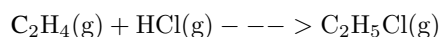

Alternative Methods of Production of Ethyl chloride

Some other methods of production of ethyl chloride have been highlighted below:

1. Chloroethane can be synthesized by the hydrochlorination of ethane.
2. It is generated as a by product in the synthesis of polyvinyl chloride.
3. In the past, chloroethane has also been produced from ethanol and hydrochloric acid.

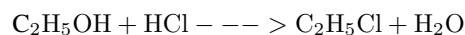

4. It can also be synthesized by the oxychlorination of ethane.

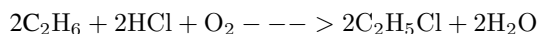

II. PROCESS DESCRIPTION AND METHODOLOGY

The gas phase hydrochlorination of ethylene was modelled using the DWSIM software (version 5.2) and the results obtained were compared with the results generated by executing the same simulation on the chemical simulator, ASPEN PLUS v10.

Process Description

Ethyl chloride is produced by the gas phase reaction of HCl with ethylene over a copper chloride catalyst and this is a highly exothermic reaction. The production of ethyl chloride is assumed to be a steady state process [2].

A feed stream composed of 50 mole-percent HCl, 48 mole-percent ethylene and 2 mole-percent nitrogen at 100 kmol/hour, 25°C and 1 atm pressure enters the reactor (conversion reactor). A conversion of 99 percent was used that was calculated manually using thermodynamics (Gibbs free energy). The separation of ethyl chloride from the unreacted reactants was achieved by compression followed by cooling which would result in two phase formation. The more volatile reactants after cooling can be easily separated from the liquid ethyl chloride. This separation was achieved using a gas-liquid separator. The unconverted reactants, namely, ethylene, HCl and nitrogen were recycled back to the mixer. To prevent the accumulation of inerts in the system, a proportion of the recycle stream was withdrawn as a purge stream.

Methodology

The following is the sequence of steps followed to execute the simulation of ethyl chloride production using DWSIM:

1. The simulation was started on the DWSIM software.
2. On proceeding to a new simulation environment, the NRTL (Non-Random Two Liquid model) thermodynamic property package was chosen. This property package was used to evaluate the equilibrium data of vapour-liquid equilibria (VLE) and liquid-liquid equilibria (LLE) during the simulation of the production of ethyl chloride on DWSIM.
3. The compounds involved in the synthesis were then added. These included the reactants hydrogen chloride, ethylene and nitrogen, and the product ethyl chloride.
4. A default flash algorithm was selected for the simulation. The simulation was carried out using the selected NRTL property package.
5. From the list of flowsheet objects, the necessary process equipment, namely, material streams, energy streams, stream mixer, conversion reactor, compressor, cooler, gas-liquid separator, stream splitter, expander and recycle block were added.
6. The equipment was arranged in the simulation environment and the appropriate material streams were attached and named accordingly as depicted in the flowsheet given below (Fig. 1).
7. The feed material stream was fed at the rate of 100 kmol/hour with specified mole fractions of the reactants (HCl-0.5, ethylene-0.48, nitrogen-0.02).
8. Using the Reaction Manager tool, the components of the reaction and their stoichiometric coefficients were mentioned. The conversion was found using thermodynamics of the reaction.
9. In the stream splitter, the top stream consisting of mostly ethylene, HCl and nitrogen from the gas-liquid separator was split in such a way that 50 percent was sent as the recycle stream and 50 percent as the purge stream.
10. An expander and heater were used to bring the recycle stream to the feed conditions.

The property package and systems chosen were highlighted in Table I. The flowsheet for the given process was shown in Fig. 1.

TABLE I
BASIS FOR SIMULATION

Compounds	Property package	Flash algorithm
Ethyl chloride Ethylene Nitrogen HCl	NRTL	Default (nested loops)

III. RESULTS AND DISCUSSION

The simulation results of the main streams were shown in Table II. The reactor outlet is a gas phase stream composed of ethyl chloride and other unreacted reactants. To separate ethyl

chloride from unreacted reactants, the stream was compressed and cooled to facilitate the formation of liquid ethyl chloride. The pressure was varied from 5 to 35 bar and its effect on the amount of ethyl chloride produced was observed in Fig. 3. No significant changes were perceived with compression beyond 20 bar in the liquid ethyl chloride formation. This is because above 20 bar pressure, the temperature of the product stream becomes very high and it is difficult to cool it further. The effect of temperature of the cooled stream of liquid ethyl chloride formed was shown in Fig. 4. It was seen that as the cooler outlet temperature increased the flow rate of liquid ethyl chloride being produced decreased. The outlet temperature of the cooler was thus fixed at 20°C since no significant change was observed in the amount of liquid ethyl chloride produced on further cooling below 20°C. From the graph plotted in Fig. 5, it can be perceived that with increase in compressor pressure from 5 to 25 bar, the outlet temperature of the compressor stream also increased from 120°C to 200°C. The compressor pressure was chosen as 20 bar for further studies.

TABLE II
MASS FLOWS OF VARIOUS MATERIAL STREAMS

Compounds	Flow rate of material streams (kg/hour)			
	Feed	Reactor outlet	G-L bottom	G-L top
ethyl chloride	0	3096.51	3074.16	22.34
ethylene	1346.592	9.485	0.023	9.46
hydrogen chloride	1823.05	87.09	71.03	16.068
nitrogen	56.028	109.598	0.27	109.32

TABLE III
TEMPERATURE AND PRESSURE OF VARIOUS MATERIAL STREAMS

Parameter	Material Streams			
	Feed	Reactor outlet	G-L bottom	G-L top
Temperature (°C)	25	25	20	20
Pressure (bar)	1.01325	1.01325	20	20

IV. THE EFFECT OF RECYCLE ON REACTOR OUTLET STREAM

The effect of the mass flow of the recycle stream on the mass flow of the reactor outlet was studied by varying the split ratio between the recycle stream and purge stream, using the sensitivity analysis tool in DWSIM.

In the sensitivity analysis shown in Fig. 2, based on the data presented in Table IV, the percentage of the gas stream (exiting gas-liquid separator) recycled was varied from 10 to 80 percent, by varying the split ratio. It was inferred that as the split ratio was increased the mass flow of the recycle stream (Stream 1 according to Fig. 2) increased. Due to this, the mass flow of the reactor outlet stream also increased.

As mentioned earlier, studies were also carried out to check the effect of compressor pressure and cooler outlet temperature

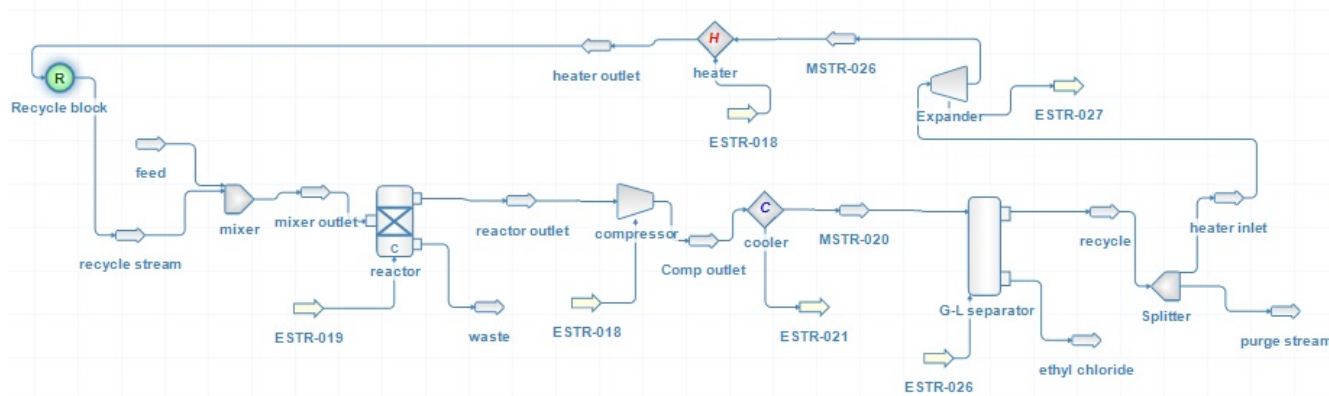

Fig. 1. Flowsheet for ethyl chloride production simulated on DWSIM

TABLE IV
SENSITIVITY ANALYSIS

Split Ratio	Reactor Outlet: ethyl chloride (kg/h)
0.1	3078.49
0.2	3082.26
0.3	3086.43
0.4	3091.26
0.5	3096.94
0.6	3104.5
0.7	3115.09
0.8	3133.67

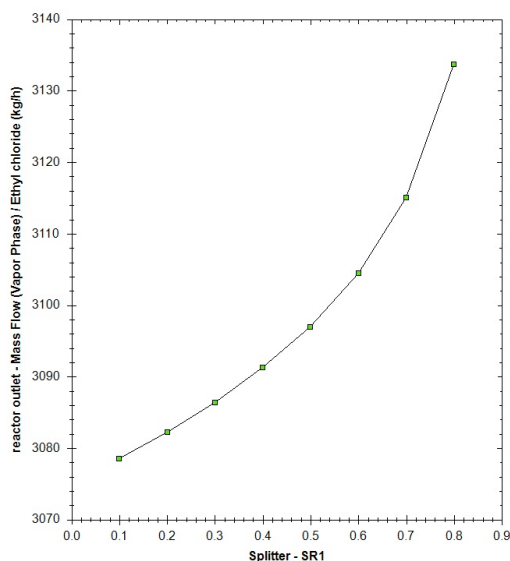

Fig. 2. Effect of recycle on reactor outlet stream

on the product flow rate (in kg/hour), shown in Fig. 3 and Fig. 4, respectively. The graph plotted in Fig. 5 showed the effect of compressor pressure on the outlet temperature of the compressor stream.

Hence, the conditions chosen for this process were based on the inferences drawn from the sensitivity analysis conducted.

A pressure of 20 bar and temperature of 20°C were found to give the best product output.

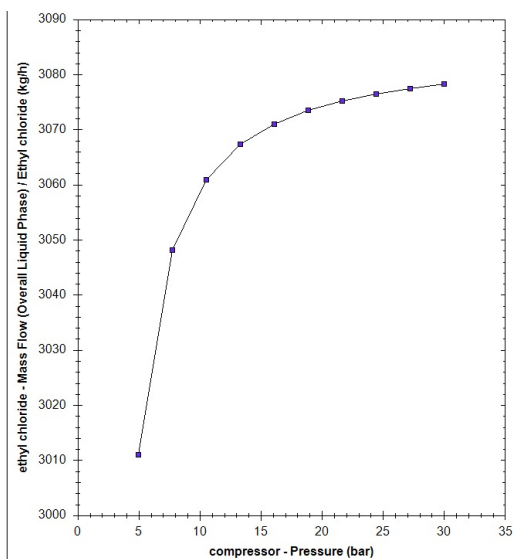

Fig. 3. Effect of compressor pressure on product flow rate

V. COMPARISON OF RESULTS OBTAINED IN DWSIM AND ASPEN PLUS

Types of Reactors Used: Gibbs, Equilibrium and Conversion reactors

A conversion of 99 percent was obtained from the thermodynamics of the reaction by calculation. The mass flows of the reactor outlet for different reactors, namely, equilibrium and conversion reactors in both ASPEN PLUS and DWSIM were compared in Table V and Table VI, respectively.

Fig. 6 depicts the flowsheet of the synthesis of ethyl chloride simulated on ASPEN PLUS v10. The conversion reactor used in DWSIM was replaced with a stoichiometric reactor in ASPEN PLUS and the results were compared.

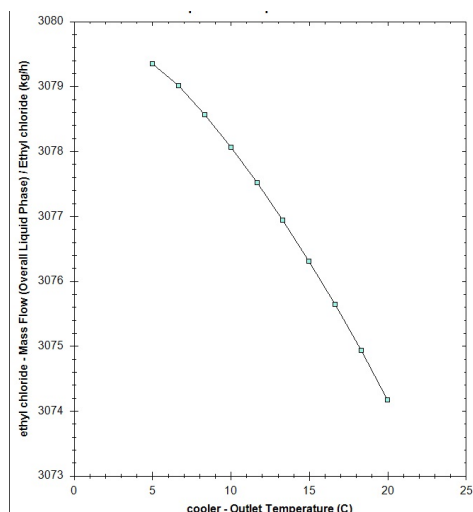

Fig. 4. Effect of cooler outlet temperature on product flow rate

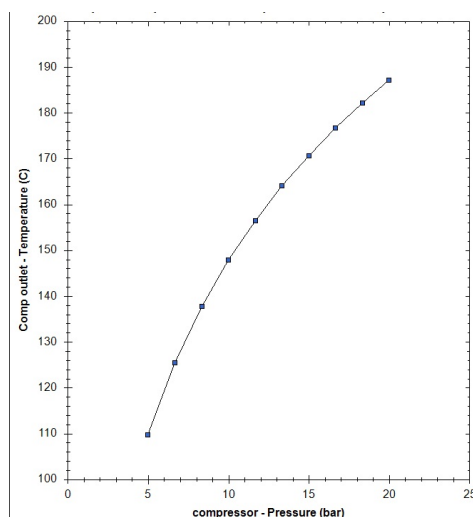

Fig. 5. Effect of compressor pressure on outlet temperature of compressor

The graph plotted in Fig. 7 shows the effect of reactor temperature on the mass flow of the product (ethyl chloride) formed in kg/hour in Aspen Plus v10. It is based on the data given in the comparison table (Table V). From this graph, it can be inferred that there is minimum variation of mass flow of ethyl chloride with increase in temperature.

Since the reaction is exothermic, increase in temperature shifts the equilibrium towards the reactants. Thus, a decrease in the formation of products was observed.

In Fig. 7, **Rgibbs** indicates Gibbs reactor and **Requib** indicates equilibrium reactor, in Aspen Plus.

Table V and Table VI depict a comparison of the process simulated using conversion and equilibrium reactors in Aspen Plus v10 and DWSIM, respectively. Here, the mass flows of the components in the reactor outlet stream have been compared using both software programs. For the same temperature, that is 25°C, the equilibrium reactor showed maximum

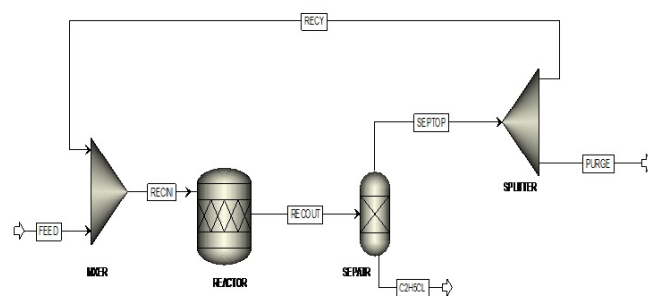

Fig. 6. Flowsheet in Aspen Plus v10

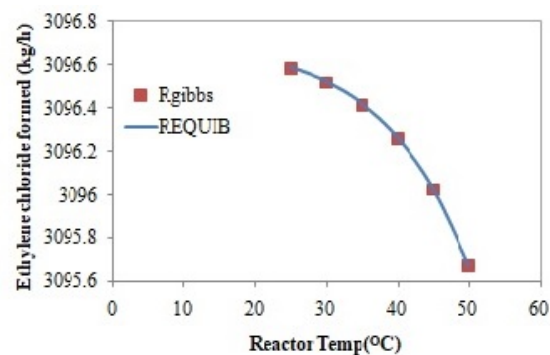

Fig. 7. Effect of reactor temperature (Aspen Plus v10)

TABLE V
COMPARISON OF MASS FLOWS FOR DIFFERENT REACTORS IN ASPEN PLUS

Compounds	Mass flows (kg/hr) (Aspen Plus)		
	Gibbs reactor	Equilibrium reactor	Conversion reactor
HCl	72.98134	72.98134	247.932
ethylene	0.046212	0.046212	134.658
ethyl chloride	3096.585	3096.585	2787.022
nitrogen	56.02696	56.02696	56.027

TABLE VI
COMPARISON OF MASS FLOWS(REACTOR OUTLET) FOR DIFFERENT REACTORS IN DWSIM

Compounds	Mass flows(kg/hr)(DWSIM)	
	Equilibrium reactor	Conversion reactor
HCl	0.4165	87.099
ethylene	approx 0	9.485
ethyl chloride	3234.55	3096.51
nitrogen	109.566	109.598

production of ethyl chloride due to high conversion . The results obtained using both software were found to be comparable.

VI. CONCLUSION

Steady state and dynamic plant simulation are powerful tools which help engineers create optimal process designs to analyze plant operations, to develop performance improvement

strategies, monitor and optimize operations. DWSIM is a chemical process simulator which was used to simulate the production of ethyl chloride.

The method described above for the production of ethyl chloride was found to be very economical and efficient as it was a simple process which proceeded with almost no by-products or side reactions. An output of 3 tons/hour was obtained.

The process was simulated using both DWSIM and Aspen Plus v10 software programs. A comparison was drawn between the results obtained from both simulations using different reactor configurations. The results of Aspen and DWSIM differed a little due to the inbuilt mechanism of solving (convergence). The effect of reactor outlet temperature on the product flow rate was also analyzed.

ACKNOWLEDGEMENT

We would like to thank the HOD and faculty, Department of Chemical Engineering, Ramaiah Institute of Technology, Bangalore for giving us the opportunity to enhance our skills in chemical process simulation by motivating us to participate in the NCCPS 2018. We extend our sincere gratitude to our professors, Dr. Mahendra Chinthala and Smt. V Sravanthi for their constant guidance and support throughout the course of our project. We are grateful to them for helping us complete our project in a limited frame of time.

REFERENCES

- [1] M. Conte, T. Davies, A. Carley, A. Herzing, C. Kiely, and G. Hutchings, Selective formation of chloroethane by the hydrochlorination of ethene using zinc catalysts, *J. Catal.*, vol. 252, 2007.
- [2] Nayef Ghasem, "Computational methods in Chemical Engineering," 1st Ed, Taylor and Francis Group, 2017.

Synthesis of p-xylene by selective methylation of toluene

Manaswini Gowtham V
Department of Chemical Engineering
Ramaiah Institute of Technology
Bangalore, India
manaswinigowthamv@gmail.com

Sneha S
Department of Chemical Engineering
Ramaiah Institute of Technology
Bangalore, India
snehashivanathan137@gmail.com

M Sunaina Poonacha
Department of Chemical Engineering
Ramaiah Institute of Technology
Bangalore, India
sunaina.poonacha@yahoo.co.in

Abstract—Para-xylene (or p-xylene) is an industrially significant compound which is used to synthesize terephthalic acid used for the production of poly-ethene terephthalate (PET). It is also used to manufacture shrink films and magnetic tapes. The proposed flowsheet was specifically designed for the production of p-xylene by considering catalysts which showed high selectivity for it, such as H-ZSM-5. In this study, the process of production of p-xylene by the selective methylation of toluene was simulated using DWSIM open source chemical process simulator. The NRTL property package was chosen as the basis for simulating the entire process. A plug flow reactor was used to execute the synthesis of p-xylene. In this process, along with the desired product, methanol of high purity was also produced. The feed was chosen (based on sensitivity analysis) to produce 20 tonnes/hour (1 US tonne = 907.185 kg) of p-xylene. The effect of reactor volume and length were also studied.

Keywords—p-xylene, Methylation, Plug flow reactor, Selectivity, Sensitivity analysis.

I. INTRODUCTION

Para-xylene is one of the three isomers of xylene. Its structure consists of a methyl group attached to the para position of a benzene ring. It is used for the industrial production of terephthalic acid, which is used to manufacture polyethylene terephthalate (PET). PET is an important requirement in the production of polyester fiber and films, and PET bottles. P-xylene can be synthesized by the catalytic reforming of naphtha. After the separation of xylene from aromatics, the p-xylene isomer has to be separated from the other isomers of xylene by using crystallization or adsorption. Since all the xylene isomers have very close boiling points, the separation of p-xylene from the xylene mixture becomes difficult and requires a lot of energy. Thus, an efficient and cost effective process must be adopted. One such alternative for the production of p-xylene is by methylation of toluene. Methylation of toluene is done by the reaction of toluene and methanol over a zeolite catalyst, such as ZSM-5, to yield water and xylene products. The other isomers do not have much industrial demand and they have to be converted to p-xylene by isomerization [1].

To increase p-xylene production, the direct conversion of toluene to p-xylene can be adopted as it eliminates the possibility of formation of other isomers which are difficult to separate.

The catalyst employed during the methylation of toluene is H-ZSM-5, which upon modification of pore size shows high selectivity towards the formation of p-xylene. Methylation of toluene occurs inside the pores of the catalyst and p-xylene having high diffusivity, comes to the external surface with ease. Structural modification of catalysts promotes the conversion of m-xylene and o-xylene into p-xylene by isomerisation inside the pore itself. Thus, the use of such engineered and modified catalysts can be used to achieve up to 80 percent selectivity of p-xylene.

Low contact time, low pressure (3 bar) and a temperature of 400°C accompanied by the modified H-ZSM-5 catalyst are used to get higher selectivity towards para xylene. The proposed flowsheet can be used to specifically manufacture para xylene and also recover methanol in appreciable amounts with high purity [2].

DWSIM, an open source chemical process simulator was used to simulate this process, which utilized the property of selective methylation of toluene over modified ZSM-5 zeolite catalyst, thus eliminating the use of a number of distillation columns which were otherwise needed when para xylene had to be separated from the isomer mixture containing m-xylene and o-xylene [1].

The following process (which has not been commercialized yet) flowsheet is suggested for the selective methylation of toluene to form only para xylene. Various catalysts are still being developed to favour the above process.

The rate equation for the reaction of toluene with methanol is given as:

$$r = k [\text{Toluene}][\text{Methanol}]$$

The reaction kinetics is as follows:

$$\text{Pre-exponential factor, } A = 408 \text{ mol/(g.h.atm)}$$

$$\text{Activation energy, } E_a = 46.1 \text{ kJ/mol}$$

The reaction of toluene with methanol is as follows:

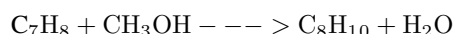

Since the catalyst being considered here is highly specific, only the reaction leading to the formation of para xylene is considered [2].

General Methods of Synthesizing p-xylene

1. Toluene Disproportionation:

This method involves the reaction of two molecules of toluene over an acid zeolite catalyst to form a xylene and benzene molecule. It is therefore feasible when benzene is also required along with the xylene products. P-xylene selectivity of 90 percent is achievable from the mixture of xylene isomers.

2. Catalytic reforming of petroleum naphtha:

This method produces p-xylene as a part of the BTX aromatics (benzene, toluene and the xylene isomers). P-xylene can be extracted from the catalytic reformat and separated out by distillation, adsorption or crystallization techniques from the m-xylene, o-xylene and ethyl-benzene. Its melting point is the highest among this series of isomers, but simple crystallization does not allow easy purification due to the formation of eutectic mixtures. Thus, the cost factor in the production of p-xylene is a major disadvantage of this method.

II. METHODOLOGY AND PROCESS DESCRIPTION

Assumptions

In this process, m-xylene, o-xylene and p-xylene were produced. However, the catalyst, H-ZSM-5, used at a temperature of 400°C and 3 bar pressure showed a high selectivity of about 80 percent for p-xylene over m-xylene and o-xylene isomers. Hence, the side reactions were also neglected. The process was assumed to be irreversible [2].

This process is specifically designed for the selective synthesis of para xylene by using modified catalysts.

Methodology

The following is the sequence of steps followed to execute the simulation of p-xylene production using DWSIM open source chemical process simulator:

1. The simulation was started on the DWSIM open source software.
2. On proceeding to a new simulation environment, the NRTL (Non-Random Two Liquid model) thermodynamic property package was chosen. This property package was used to evaluate the equilibrium data of vapour-liquid equilibria (VLE) and liquid-liquid equilibria (LLE) during the simulation of the synthesis of para-xylene on DWSIM.
3. The compounds involved in this synthesis were then added. These included the reactants toluene and methanol, and the products p-xylene and water.
4. Default flash algorithm was selected for the simulation. The simulation was carried out using the selected NRTL property package.
5. From the list of flowsheet objects, the necessary process equipment namely, material streams, energy streams, pump, heater, mixer, plug flow reactor, rigorous distillation column, cooler and decanter were added.
6. The equipment was arranged in the simulation environment and the appropriate material streams were attached and labelled, as shown in the flowsheet (Fig. 1).

7. The reactants were fed to the mixer after heating in the heater.

8. The reactants were then directed into the plug flow reactor.

9. The reactor outlet was cooled and the products were separated using a rigorous distillation column.

10. Para-xylene and water, obtained in the bottom stream were separated using a decanter.

Process Description

The production of p-xylene by methylation of toluene was simulated using the DWSIM open source software. In this process simulation, the reactants, namely, toluene and methanol which were initially at 25°C and 1 bar, were pumped into a heater with a pressure of 3 bar. The reactants were heated to a temperature of 400°C and fed to the mixer. The mixer outlet was then fed to the plug flow reactor. This reactor was considered to have a volume of 60 cubic meter and length of 1 meter.

The reaction was assumed to be irreversible and the values of activation energy and Arrhenius factor used were 46.1 kJ/kg and 408 mol/(g.h.atm), respectively. The product from the plug flow reactor outlet was in vapour phase at 400°C. It was then cooled to 50°C using a cooler. The product from the cooler outlet was fed into the rigorous distillation column in which the top stream consisted of methanol and water, while the bottom stream consisted of water and p-xylene. Since water and p-xylene are immiscible and form different phases, they were separated using a decanter. In the flowsheet created, a compound separator was used as a decanter due to the lack of a more specific unit operation model on DWSIM.

TABLE I
BASIS FOR SIMULATION

Compounds	Property package	Flash algorithm
p-xylene	NRTL	Default (nested loops)
Toluene		
Methanol		
Water		

III. RESULTS AND DISCUSSION

Table II shows the mass flows of individual components in various streams.

In Table II, **distill top** represents the mass flow of the components exiting from the top outlet of the rigorous distillation column, that is, methanol and water.

distill bottom represents the mass flow of the components exiting from the bottom outlet of the column, that is, water and para-xylene.

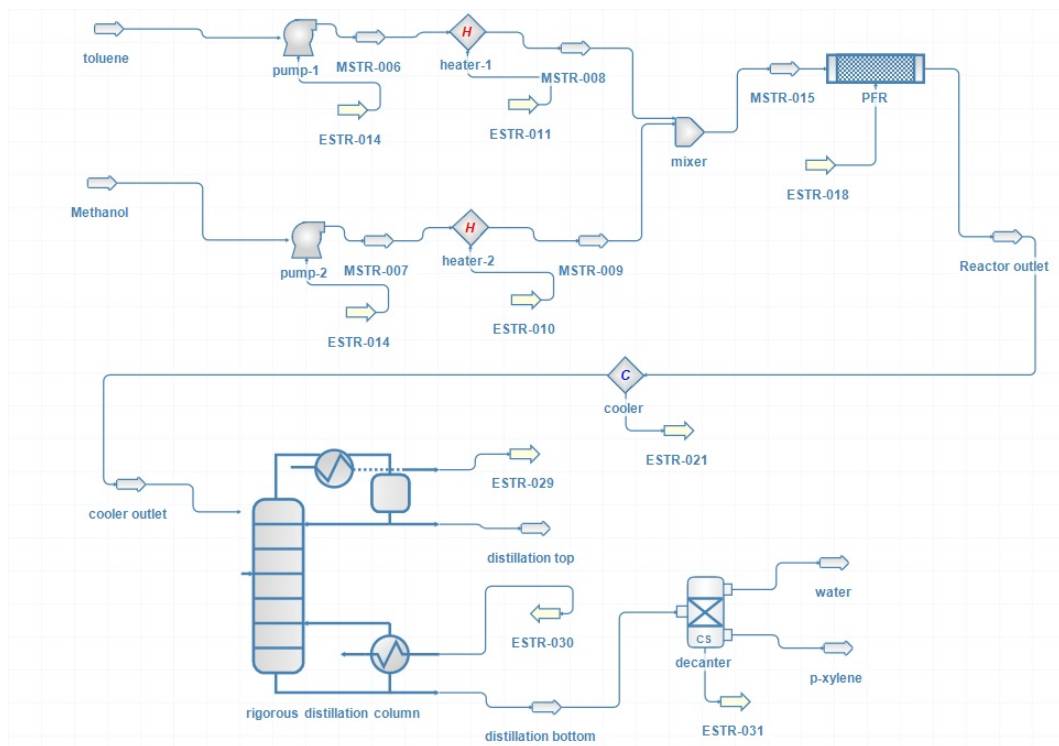

Fig. 1. Flowsheet for p-xylene synthesis by selective methylation of toluene

TABLE II
RESULT TABLE

Compounds	Mass flow of various streams (kg/hr)			
	Feed	Reactor Outlet	distill top	distill bottom
Toluene	17400	6.518×10^{-20}	1.86×10^{-20}	4.50×10^{-20}
Methanol	12613.33	6562.48	6552.50	8.49
p-xylene	0	20048.648	1015.62	19037.12
Water	0	3401.97	1447.70	1954.38

A. Sensitivity Studies

Sensitivity analysis was done as shown in Fig. 2. From the analysis, it can be seen that as the mass flow of toluene increases, the mass flow of para-xylene also increases. The mass flow of toluene in the feed stream was selected to be 17400 kg/h to produce 20000 kg/h of p-xylene. Therefore, the increase in toluene input increased the product output.

B. Effect of Reactor volume and Reactor length

For the plug flow reactor in which the reaction takes place, sensitivity analysis was done by varying the reactor volume and reactor length and noting its effect on the mass flow of para xylene in the reactor outlet.

The effect of residence time on the reactor volume was analyzed by varying the reactor length and keeping the diameter constant. Since the length of the reactor is increasing, the residence time (time taken by the reactants to cover the reactor length) also increases. Thus, from the plot

shown in Fig. 3, it can be inferred that the reactor volume increases as residence time increases.

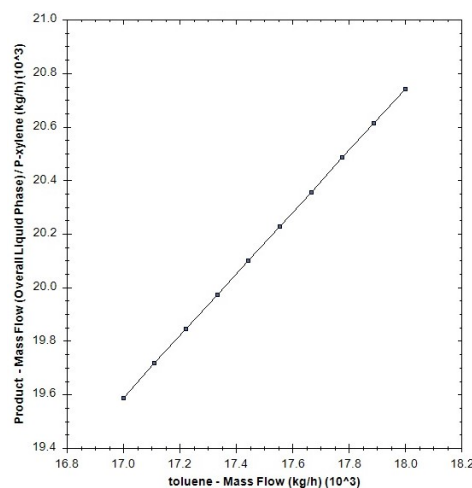

Fig. 2. Sensitivity Analysis

The effect of reactor length on the pressure drop was also analyzed. From Fig. 4 it was observed that the pressure drop increased as the length increased. When the length of the reactor is increased, the reactants have to travel a longer distance, resulting in the increase in pressure drop. Since the kinetics of the reaction is dependant only on the

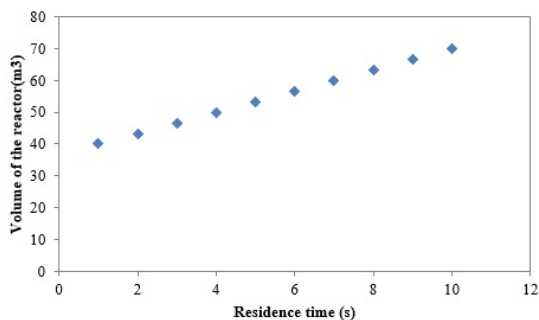

Fig. 3. Effect of reactor volume

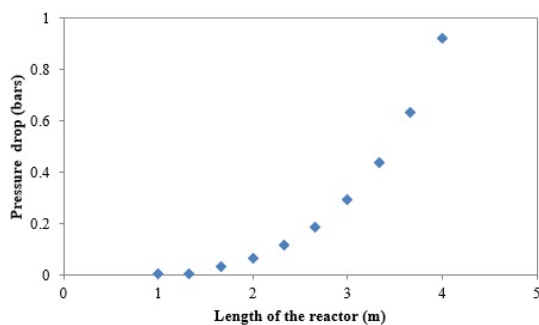

Fig. 4. Effect of reactor length

temperature and concentration, change in any other factor such as reactor volume or length will not effect the product formation. This is because, hydrodynamic factors (such as pressure drop) vary proportionately so as to compensate for changes in volume and length.

IV. CONCLUSION

The process of synthesis of p-xylene by the methylation of toluene was simulated using DWSIM open source chemical process simulator. The kinetics of the reaction in the plug flow reactor was input initially. The simulation gave appreciable results for the given kinetics. This process can thus be used specifically for the selective synthesis of para-xylene. Using this process, methanol could also be recovered in appreciable amounts. Based on the sensitivity analysis, the feed rate for toluene was chosen as 17400 kg/hour to obtain 20 tonnes/hour of the product, p-xylene. The effects of reactor volume and length were also studied using sensitivity analysis.

ACKNOWLEDGEMENT

We would like to thank the HOD and faculty, Department of Chemical Engineering, Ramaiah Institute of Technology, Bangalore for giving us the opportunity to develop our skills in chemical process simulation by encouraging us to take part in the NCCPS 2018. We would like to extend our sincere gratitude to our professor, Dr. Mahendra Chinthala for guiding and supporting us throughout the duration of the project.

REFERENCES

- [1] Muhammad Tahir Ashraf, Rachid Chebbi,* and Naif A. Darwish, Process of p-xylene production by highly selective methylation of toluene, *Ind. Eng. Chem. Res.*, 2013.
- [2] A.K. Aboul-Gheit, A.A. Aboul-Enein, S.A. Ghoneim, S.A. Hanafi, and A.E. Awadallah, Catalytic para-xylene maximization. Part X: Toluene disproportionation on HF promoted H-ZSM-5 catalysts, *Egypt. J. Pet.*, vol. 21, 2012.
- [3] L. Young, Shape selective reactions with zeolite catalysts III. Selectivity in xylene isomerization, toluene-methanol alkylation, and toluene disproportionation over ZSM-5 zeolite catalysts, *J. Catal.*, vol. 76, 1998.

Using “DWSIM” for Understanding Chemical Reaction Equilibrium

A.S. Amharnath
School of Chemical & Biotechnology
SASTRA Deemed to be University,
Thanjavur, Tamil Nadu, India
nathbrothers241198@gmail.com

S. Pranaav
School of Chemical & Biotechnology
SASTRA Deemed to be University,
Thanjavur, Tamil Nadu, India
spranaav1850@gmail.com

P. R. Naren*
School of Chemical & Biotechnology
SASTRA Deemed to be University,
Thanjavur, Tamil Nadu, India
prnaren@scbt.sastra.edu

Abstract—Reaction engineering and reactor design is one of the most important and fundamental aspect of process engineering. Equilibrium reactions are common in the process industry. Process simulation software like DWSIM can be used to get insight and thus have better understanding of equilibrium reactions. The use of DWSIM as a learning tool for undergraduate students for learning of chemical reaction equilibria is thus presented in this work.

Keywords— DWSIM, Equilibrium Reactions, Simulation, Learning Tool

I. INTRODUCTION

Reaction engineering is an integral part of the process industry. Concepts of chemical reaction equilibrium are taken up in this work. Equilibrium reactions are common in the process industry. For example, synthesis of Ammonia by Haber’s Process is a classic example of an equilibrium reaction. Thus, understanding of equilibrium reactions can help to identify conditions that can maximise the conversion of a particular process. DWSIM is a free and open source process simulation tool. In the present work DWSIM is explored as a tool to complement learning of the fundamentals of reaction equilibrium and thus better understand the same. Synthesis of methanol is taken as an illustrative example and DWSIM is used to study the effect of various scenarios such as effect of temperature, pressure, feed composition on equilibrium conversion.

II. EFFECT OF OPERATING TEMPERATURE

A. Background

One of the main process routes for production of methanol is production from synthesis gas [1]. This is an exothermic reaction wherein carbon monoxide and hydrogen catalytically react to produce methanol. Mixture of zinc and copper oxides, supported on alumina is most widely catalyst for this process. The reaction has high selectivity at 5–10 MPa and 250 °C [2].

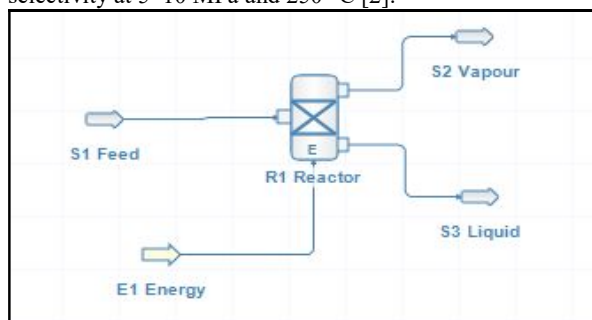

Fig. 1. Image of steady state simulation of the equilibrium reactor of the flowsheet used in DWSIM

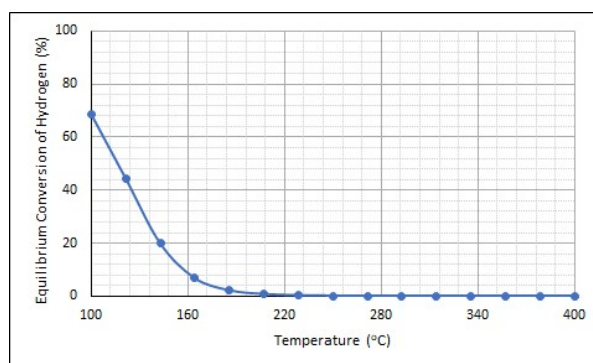

Fig. 2. Equilibrium conversion of hydrogen as function of temperature for methanol synthesis at 1 atm with CO and H₂ in feed in stoichiometric ratio

B. Reaction Scheme



C. Flowsheet Description

Methanol from synthesis gas is produced using an Equilibrium reactor block in DWSIM. Raoult’s law was used as thermodynamic package. The reaction pressure was fixed as 1 atm. The feed consisting of carbon monoxide and hydrogen in stoichiometric ratio of 1:2 was sent to the reactor. The total molar flow rate was fixed at 27.8 mol/s and this corresponds to 100 kmol/h. The base component was taken as hydrogen. An equilibrium reactor with isothermal mode of operation was used. The reaction was simulated for a range of temperatures using sensitivity analysis tool of DWSIM and the conversion at each temperature was found out. The flowsheet is shown in Fig 1.

D. Results

The results obtained from simulation are shown in Fig. 2. It is evident from the Fig. 2, that for exothermic reactions, the equilibrium conversion decreased with increase in reaction temperature.

III. EFFECT OF OPERATING PRESSURE

A. Background

The production of methanol from syn gas is simulated at different operating pressures. The feed consists of carbon monoxide and hydrogen in stoichiometric quantities.

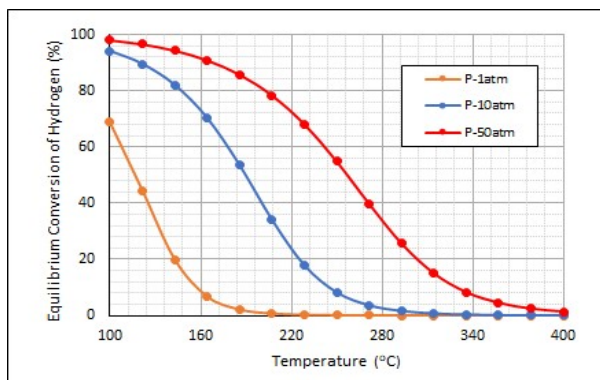

Fig. 3. Equilibrium conversion of hydrogen as function of temperature for methanol synthesis at various pressures with CO and H₂ in feed in stoichiometric ratio

B. Flowsheet Description

Methanol was produced from synthesis gas. Raoult's law was used as thermodynamic package. The reaction pressure was fixed as 1, 10 and 50 atm. The feed consisting of carbon monoxide and hydrogen in stoichiometric ratio of 1:2 was sent to the reactor. The total molar flowrate was fixed at 27.8 mol/s. The base component was taken as hydrogen. An equilibrium reactor with isothermal mode of operation was used. The reaction was simulated for a range of temperatures and the conversion at each temperature was found out.

C. Results

The results from the simulation are shown in Fig. 3. It is evident from Fig. 3, that for reaction with decrease in mol number in the forward reaction scheme, increase in operating pressure is found to favour the forward reaction and thus increase equilibrium conversion.

IV. EFFECT OF LEAN FEED MIXTURE

A. Background

In this case study, effect of feed composition is simulated. For methanol formation from syn gas, 1:2 molar ratio of carbon monoxide to hydrogen is required as per reaction stoichiometry. Instead of 1:2, in this case study, feed stream with equimolar ratio of carbon monoxide and hydrogen is fed to the reactor.

B. Flowsheet Description

Raoult's law was used as thermodynamic package. The reaction pressure was fixed as 1 atm. An equimolar feed of carbon monoxide and hydrogen was sent into the reactor. The base component was taken as hydrogen. The molar flowrate of hydrogen in the feed mixture was fixed as 18.6 mol/s. An equilibrium reactor with isothermal mode of operation was used. The reaction was simulated for a range of temperatures and the conversion at each temperature was found out.

C. Results

The simulated results are shown in Fig. 4. For a 1:1 feed of CO:H₂, hydrogen is a limiting reactant and hence conversion of hydrogen is expected to be more than that of 1:2 stoichiometric feed of CO:H₂ (Fig. 4)

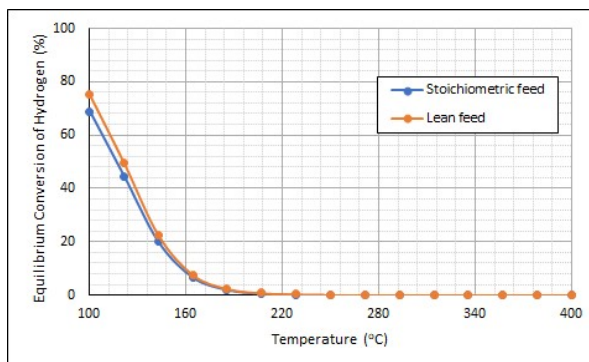

Fig. 4. Equilibrium conversion as function of temperature for methanol synthesis at 1 atm with CO and H₂ in feed in stoichiometric and with a lean feed mixture

V. EFFECT OF INERT IN FEED STREAM

A. Background

The effect of inert like nitrogen on conversion is studied in the present work.

B. Flowsheet Description

Methanol was synthesised in the presence of Nitrogen as an inert compound. The property package of Raoult's law was used. The reaction pressure was fixed at 10 atm. The feed consists of 1:2:2 mol ratio of CO: H₂: N₂. The base component was taken as hydrogen. The molar flowrate of hydrogen in the feed mixture was fixed at 18.6 mol/s. An equilibrium reactor with isothermal mode of operation was used. The reaction was simulated over a range of temperature and conversion at each temperature was found out.

C. Results

The results from the simulation are shown in Fig. 5. For an ideal multicomponent system based on the principles of reaction equilibrium, it is expected that the presence of inert will favor the backward reaction, provided the forward reaction proceeds with decrease in number of moles. The simulated results shown in Fig. 5 confirm the effect of inert.

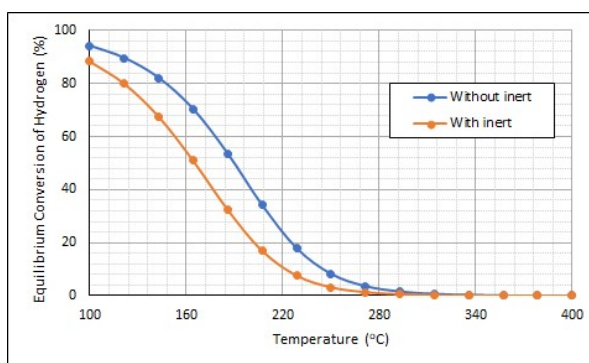

Fig. 5. Equilibrium conversion as function of temperature for methanol synthesis at 10 atm with CO and H₂ in feed with and without the presence of inert

VI. EFFECT OF PRODUCT SPECIES IN FEED STREAM

A. Background

The presence of products in an equilibrium reaction tends to drive the reaction in the reverse direction. The methanol production reaction is studied with methanol present in the feed initially.

B. Flowsheet Description

Methanol was synthesised with the presence of methanol in the feed. The property package of Raoult's law was used. The pressure was fixed at 10 atm. The base component was taken as hydrogen. The molar flowrate of hydrogen in the feed mixture was fixed at 18.6 mol/s. The feed was sent in the ratio of 1:2:1 for CO: H₂: CH₃OH. An equilibrium reactor with isothermal mode of operation was used. The reaction was simulated over a range of temperatures and the conversion at each temperature was found out.

C. Results

The results from Fig. 6 showed that the conversion reduced with increasing temperature. Further, with the presence of methanol in the feed, the reversible endothermic reaction is found to occur and thus methanol decomposes to produce hydrogen. Hence, the conversion of hydrogen decreases. The effect is more pronounced at higher temperature as the reverse reaction is endothermic in nature.

VII. CONCLUSIONS, DISCUSSIONS AND FURTHER WORK

In this work, using DWSIM, various scenarios or cases of reversible reactions are investigated. Sections II, III and IV, V and VI highlight some of the important features that can be analysed for a single equilibrium reaction. This work can be extended to multiple reactions in equilibrium, and shall be presented at the conference. A comparison with simulated results obtained from Aspen Plus (Aspen Tech., Inc., USA) will also be presented at the conference. DWSIM can be used as an efficient teaching & learning tool as part of a typical undergraduate course in chemical reaction equilibria. An undergraduate student with a basic knowledge of DWSIM can use the tool to explore, learn and thus better understand reaction equilibria. This will promote self-learning and shall further enhance and validate his or her reflection of the concepts learnt in class.

ACKNOWLEDGMENT

Two of the authors would like to thank A.S. Rahul, FOSSEE, IIT-Bombay for providing guidance in DWSIM simulations.

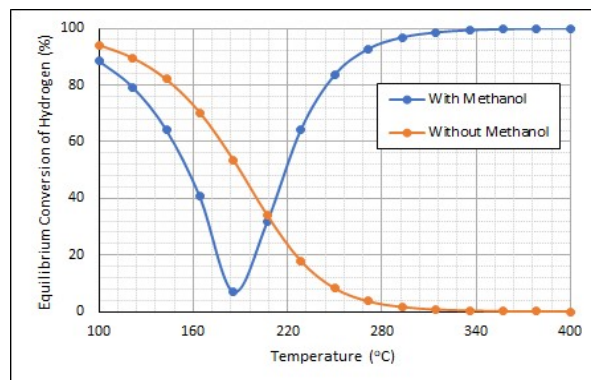

Fig. 6. Equilibrium conversion as function of temperature for methanol synthesis at 10 atm with and without the presence of methanol in feed mixture

REFERENCES

- [1] L.C.L.A. Jamshidi, C.M.B.M. Barbosa, L. Nascimento and J.R. Rodbari, "Catalytic Dehydration of Methanol to Dimethyl Ether (DME) Using the A_{162,2} Cu_{25,3} Fe_{12,5} Quasicrystalline Alloy", J Chem Eng Process Technology, 4:5, 2013
- [2] URL: <https://en.wikipedia.org/wiki/Methanol>

Using DWSIM for Analysis of Energy Streams in Process Flowsheets

R. Charan

*School of Chemical and Biotechnology,
SASTRA Deemed to be University,
Thanjavur, Tamil Nadu, India.
charankrg@gmail.com*

P. R. Naren

*School of Chemical and Biotechnology,
SASTRA Deemed to be University,
Thanjavur, Tamil Nadu, India.
prnaren@scbt.sastra.edu*

Abstract—Analysis of energy consumption in a process requires rudimentary knowledge about various energy exchange operations in process industries. Process simulation softwares like DWSIM provide us with a platform to gain a solid understanding on the operations. DWSIM was chosen in the present work as it is an Free and Open Source Software (FOSS). Three different process flowsheets are simulated in DWSIM to demonstrate the use of DWSIM in analysis of energy flow in process industries.

Keywords—Energy, Analysis, DWSIM, Flowsheet, Python.

I. INTRODUCTION

Energy utilisation is integral part of any process industry. A significant part of the operating costs are spent on energy production and utilisation. Therefore methods are continuously developed to effectively use energy. Process simulation softwares provide a more accessible alternative to get an insight into energy utilisation at industries. The present work focuses on using simulation software to understand energy analysis techniques. DWSIM, a process simulation software, is chosen over other proprietary simulation software as it is an Free and Open Source Software (FOSS). Different flowsheets are simulated to show the various methods DWSIM can be used as an aid in understanding energy flow in process industries.

II. ENERGY CONSUMPTION IN A SEPERATION TRAIN

A. Background

Distillation is one of the most common and energy-intensive separation processes. These are used extensively in various chemical indstries to separate components from mixtures. In this the feed usually contains more than two components. The distillation columns are placed in series where at each column atleast one component is desired to be separated from the mixture based on their relative volatility. For streams containing more than 2 components, there could be more than one way to sequence and separate the components [1]. Therefore, the sequencing of distillation columns plays a major role in designing the separation process. In this work, two different sequences of distillation columns are simulated to separate a mixture containing aliphatic alcohols

namely Methanol, Ethanol and 1-propanol and the results are compared to draw meaningful conclusion. The developed flowsheet is made available at DWSIM flowsheeting Project [2].

B. Flowsheet Description

Consider a typical separation process wherein mixture of three aliphatic alcohols such as Methanol, Ethanol and Propanol are required to be separated using a distillation train. The normal boiling points of these three components are 338 K, 352 K and 370 K respectively. A specification of 99.9 mol percent pure component is set as target for the separation process. To study the effect of sequencing of distillation column the feed is split equally using a splitter into two streams as shown in Figure 1. The split streams are sent to two different sequence of distillation column, namely sequence-1 and sequence-2. In sequence-1, 1-propanol is removed in the first distillation column (DC-1) as residual stream. The distillate from DC-1 is then sent to next distillation column (DC-2) where Methanol of required purity is obtained as distillate and Ethanol as residue. Similarly, in sequence-2, Methanol is initially removed in the first distillation column of the sequence-2 (DC-3) as distillate. The residue from DC-3 is then sent to the next distillation column (DC-4) where Ethanol and 1-propanol are separated and obtained as distillate and residue respectively. The reflux ratio, condenser pressure and reboiler pressure are maintained at the same value for comparison purposes. For sake of brevity, it is assumed that components are ideal and follows Raoult's law.

C. Results

The heat duty of condenser and the heat duty of reboiler are compared. DC-1 and DC-2 are distillation columns pertaining to sequence-1 whereas DC-3 and DC-4 are that of sequence-2. From the results in Table I, it is observed that sequencing of distillation columns affects the total energy requirement of the process. For the same target purity, one separation train sequence can be more energy intensive than the other. Hence, simulation tools helps to identify and choose

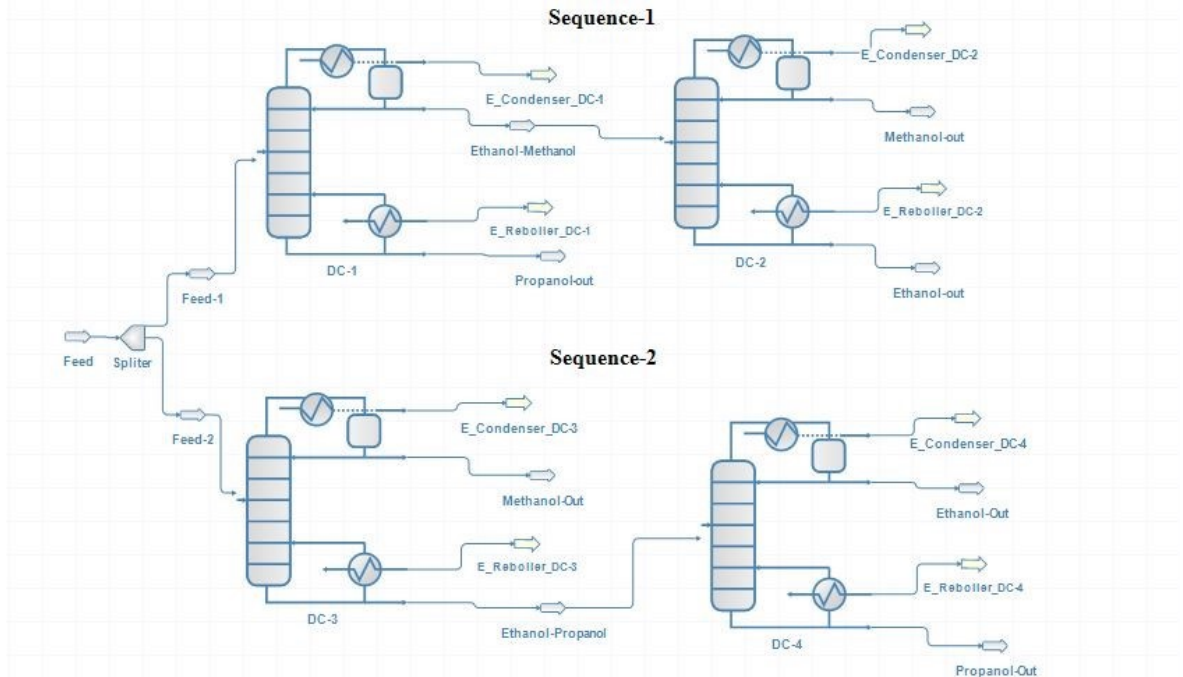

Fig. 1. Distillation column sequences for separation of aliphatic alcohols

a more appropriate sequence for the given process.

TABLE I
HEAT DUTY IN REBOILER AND CONDENSER

Object	Energy requirements*			
	Sequence 1		Sequence 2	
	DC-1	DC-2	DC-3	DC-4
Reboiler	5503.96	2093.76	2176.21	3374.16
Condenser	5150.88	2088.47	1632.33	3360.85

*All units are in MW.

III. ENERGY STREAM RECYCLE

A. Background

Methane is used in petrochemical industries as a precursor for the production of high quality hydrogen. This is usually done by steam reforming where steam is reacted with methane to form carbon monoxide and hydrogen [3]. The dry reforming of methane is a similar process where methane is reacted with carbon dioxide instead of steam to produce hydrogen and carbon monoxide (syngas). This process is usually favoured at low temperatures and high pressures. Dry reforming of methane is environmentally very attractive as it utilizes two greenhouse gases to give a useful product.

B. Flowsheet Description

Two feed streams containing methane and carbon dioxide respectively are sent into the mixer as shown in Figure 2. The feed streams are at same conditions of 1 atm and 50 C with

a molar flow rate of 1000 kmol/h. The mixed stream is then sent to a heater where it is heated with energy exchanged from the recycled stream. The heated stream is then sent to an equilibrium reactor. The product consisting of syngas with little amounts of methane and carbon monoxide is then cooled using a cooler to 323.15 K. The energy generated from cooling the stream is recycled and used by the heater to heat the reactant stream. The developed flowsheet is made available at the DWSIM flowsheeting Project [4]

C. Results

It is seen that 26.13 MW of energy is being recycled from the cooler to the heater for the given flowsheet under the specified input conditions. This in turn causes the heater to raise the temperature of the feed stream from 323.15 K to 1503.48 K. The energy recycled can be adjusted by changing the cooler outlet temperature. An optimum cooler temperature can be figured out for which the feed is heated to a temperature that gives the required conversion by performing a sensitivity analysis. This work signifies the usefulness of DWSIM in understanding the energy recycle process in a easy manner.

IV. ANALYSIS OF OVERALL ENERGY REQUIREMENT

A. Background

Aniline, also known as Amino benzene or Benzenamine, is an aromatic amine with the formula C₆H₅NH₂. It is mainly used as a raw material in the production of Methylene

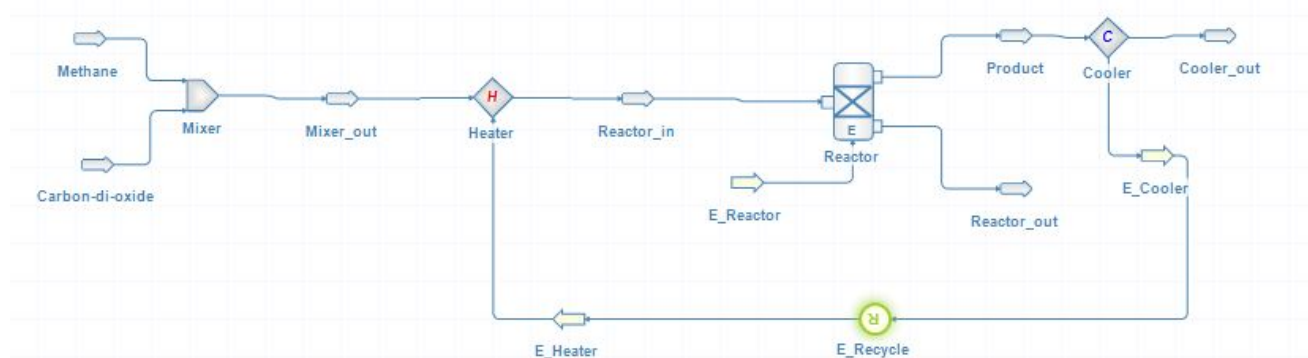

Fig. 2. Dry reforming of methane with energy stream recycle

diphenyl diisocyanate (MDI), an intermediate in polyurethane manufacture. MDI production alone accounts for over 95 percent of world aniline consumption. Aniline is also used as an intermediate for dyes and pigments, explosives, agricultural chemicals and pharmaceuticals. It was first commercially produced using Nitrobenzene as starting material around 1930 [5]. This pathway remains the most common method for aniline production today. Currently, almost all existing plants producing Aniline from Nitrobenzene are integrated with facilities to produce Nitrobenzene from Benzene.

B. Flowsheet Description

The flowsheet simulates the production of 10 TPD of Aniline from Nitrobenzene with addition of Hydrogen as shown in Figure 3. The feed stream consists of Nitrobenzene and Hydrogen. The composition of the feed stream is 75 mol percent Hydrogen and 25 mol percent Nitrobenzene. The feed is sent at conditions of 600 K, 1 atm and at a mass flow rate of 600 kg/s. This stream (feed) is sent to a conversion reactor where the conversion of the reaction is fixed at 99.9 percent with respect to Nitrobenzene. Since the conversion is very high, the product stream from the reactor has a composition of 33 percent Aniline and 66 percent Water with negligible amounts of the reactants (approx. 1 percent). The product stream is then passed through a cooler where it is cooled to 300 K. The cooled water is then sent to the distillation column where water is removed through the distillate stream and Aniline is obtained through the residue stream. Aniline obtained is at a purity of almost 99 percent. Considering the energy streams, energy is being supplied to the reactor and the reboiler of the distillation column while energy is being extracted from the cooler and the condenser of the distillation column. The developed flowsheet is made available at the DWSIM flowsheeting Project [6]. Typically a process engineer wishes to know about the total energy requirement, summing the energy requirement of all individual operations. DWSIM reports individual energy consumptions but does not report the total for the entire flowsheet. However, DWSIM has a flexible feature of running a python script in a flowsheet

[7]. In this work, a simple python script is developed and is incorporated into the flowsheet to calculate the overall energy flow in the process.

C. Results

The energy flowing in each energy stream is tabulated in II. The overall energy required by the process is estimated by the script to be 1370.22 MW. This value is verified by calculating the energy required from Table II. DWSIM has such powerful scripting tools which can be utilised to calculate various values. The script is a generic one and can be used for any kind of process. The script can also be modified to include only certain energy streams if only a part of the process needs to be studied. Such tools are extremely useful in energy analysis of a process.

TABLE II
ENERGY FLOW IN ANILINE PRODUCTION

	Energy Extracted		Energy Supplied	
	Cooler	Condenser	Reactor	Reboiler
Energy Flow	905.30	853.90	2197.42	932.00

^aAll units are in MW.

V. CONCLUSIONS AND DISCUSSION

Three different flowsheets are shown in the present work to elucidate usefulness of DWSIM in understanding energy flow. Section II explores the usefulness of DWSIM in identifying the appropriate sequencing train based on the energy requirements. Section III showcases the option of energy recycle in DWSIM. This process is known as pinching is used extensively in various industries. Understanding effective use of energy recycle is integral to the optimisation process. Section IV delves deep into DWSIM and explores scripting options that can essentially make energy analysis easier. Python script is a powerful tool which enables us to automate many calculations. Therefore it can be concluded that DWSIM can certainly aid in analysis of energy streams.

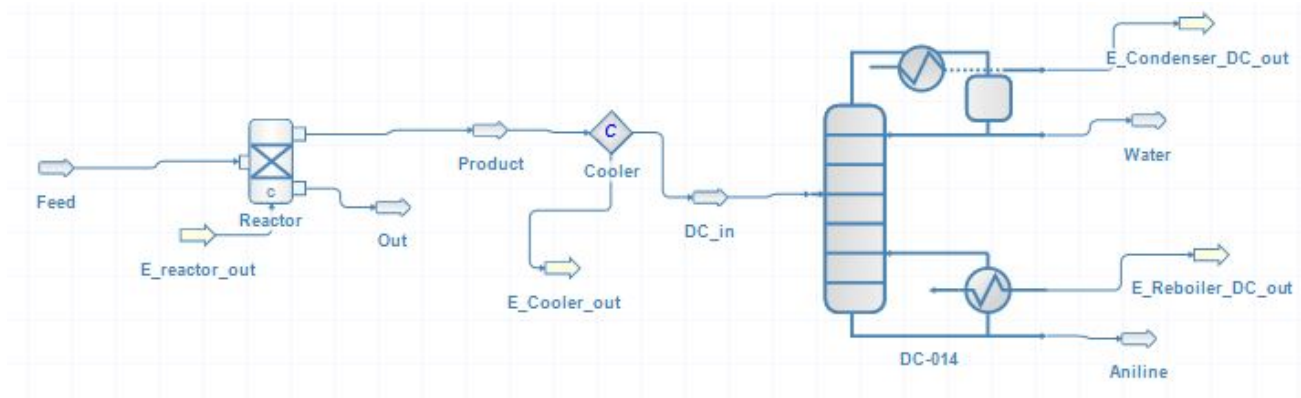

Fig. 3. Aniline production process from hydrogen and nitrobenzene

DWSIM can thus be used as an effective tool by students, practising engineers for analysing energy streams in process and make appropriate decisions.

ACKNOWLEDGMENT

The author (Charan) thanks FOSSEE, IIT-Bombay for providing an opportunity to work on this project as part of FOSSEE Summer Fellowship 2018 during May - June 2018 at IIT-B, Mumbai. The author is also grateful to Priyam Nayak and Ragul A. S. for providing guidance throughout the work.

REFERENCES

- [1] Andreas Harwardt, Sven Kossack, Wolfgang Marquardt, "Optimal column sequencing for multicomponent mixtures", *Computer Aided Chemical Engineering*, 25, 91-96, 2008
- [2] <https://dwsim.fossee.in/flowsheeting-project/dwsim-flowsheet-run/208>.
- [3] Luyben W. L., "Design and Control of the Dry Methane Reforming Process", *Industrial and Engineering Chemistry Research*, 53(37), 14423-14439, 2014
- [4] <https://dwsim.fossee.in/flowsheeting-project/dwsim-flowsheet-run/197>
- [5] <http://www.chemengonline.com/aniline-production-nitrobenzene-liquid-phase-intratec-solutions/>
- [6] <https://dwsim.fossee.in/flowsheeting-project/dwsim-flowsheet-run/206>
- [7] <https://sourceforge.net/p/dwsim/discussion/scripting/>

Effect of Thermodynamic Model Parameters on simulation of distillation column

Naitik Choksi
Dept. of Chemical Engineering
Nirma University
Ahmedabad, India
naitikchoksi@yahoo.co.in

Tushar Perkar
Dept. of Chemical Engineering
Nirma University
Ahmedabad, India
tusharperkar97@gmail.com

Dr. Milind Joshipura
Dept. of Chemical Engineering
Nirma University
Ahmedabad, India
milind.joshipura@nirmauni.ac.in

Abstract— In the present paper, Aspen HYSYS is used as a simulator to showcase the effect of Binary Interaction Parameters (BIP's) on the results of Shortcut Distillation simulations. Out of the 46 binary systems considered, 40 of them did not have inbuilt BIP's in Aspen HYSYS. We simulated 23 systems using the Wilson thermodynamic package and 17 systems using NRTL. The boiling point differences between the two components in the systems ranged from 2.4 to 84.9°C. The maximum Global %AAD obtained for Wilson was 19.2%, while the maximum Global %AAD obtained for NRTL was 3.3%. The average absolute deviation of a data set is the average of the absolute deviations from a central point. The NRTL model gave smaller deviations than Wilson, and therefore is considered as more stable. The results for NRTL in Aspen HYSYS have been compared with the same simulations performed in DWSIM. These results will surely help to improve the simulations of Shortcut Distillation with proper use of BIP's and further help to decrease the errors in design of distillation columns.

Keywords—Aspen HYSYS, Shortcut Distillation, Binary Interaction Parameters, NRTL, Wilson, DWSIM

I. INTRODUCTION

Process Simulation covers the entire life cycle of the process, from R&D to conceptual design to plant operations. It is a very important part of process design as it allows engineers to model a process virtually without having to invest manpower, money or time to physically test their design in the real environment.

Steady state simulations are performed during the design phase to understand how the design can be modified to get the most optimum results, both from engineering and business point of view. Dynamic simulations allow the engineer to virtually run the designed process under different conditions to ensure that the process remains stable and safe under extreme or abnormal conditions.

Therefore, simulation helps to eliminate the cost and time required for physical testing of the design, to optimise the design from engineering and business point of view and to test the safety of the process.

A. Simulation of distillation column:

Distillation is the separation of key components of a stream on the basis of the difference in their relative volatilities, or boiling points. Due to its prevalent usage in any chemical industry, it has become necessary to simulate the distillation operation first and then design and fabricate it. The simulation of distillation provides an insight into the operating costs and capital costs that would be involved, by furnishing the data of number of stages of the column, the

reboiler and condenser duties, the reflux ratio required for the required purity.

B. Impact of thermodynamic models

In today's generation chemical engineers often find themselves to be dependent on powerful process simulation software, programs for projects in their occupation or any form of research. It is likely to be seen that due to the lack of experience in operation of process simulators, they end up making a poor choice in selecting a physical property package or not specifying the binary interacting parameters for a system of components.

BIP's represent the molecular interaction occurring between 2 components of a binary system. They provide an idea about the extent of non-ideality of the system. Legitimate choice of proper binary interaction parameters and thermodynamic models amid process simulation is essential as a beginning stage for precise process re-enactment. A completely optimized process in terms of operating parameters, equipment selection, unit operations etc. is completely worthless if simulation relies on inappropriate thermodynamic models.

It is observed that an inaccurate choice of thermodynamic models has a strong impact on the field of designing. For example, the design margins that we obtain through simulations may be greater than what is needed and this effect significantly magnifies the cost of the project, induces poor design choices, and ultimately results in reduced production capacity. Thermodynamic model at the same time also affects the rating and sizing of the process equipment hence the efficiency and accuracy of unit operations and processes.

According to our literature survey, we found that research has been done on the impact of selection of thermodynamic packages on the results of simulation [1], but very less research has been done on the impact of binary interaction parameters on the results of distillation simulation, due to which we performed a study on the impact of binary interaction parameters on the results of ShortCut Distillation (SCD) using Aspen HYSYS and DWSIM.

II. DATABASE AND METHODOLOGY:

VLE Data along with binary interaction parameters (BIP's) for 46 binary systems were collected. All these systems were checked in Aspen HYSYS's, DWSIM's component library for availability of inbuilt BIP's. Systems

were then bifurcated on the basis of presence of BIP's. Systems without BIP's were used for simulation, while shown in Table 1.

those systems which had inbuilt BIP's were eliminated. Total 40 cases were simulated using Wilson and NRTL, as

TABLE 1 Systems Used In Simulation

Sr. No	System	T _b Difference (°C)
	Component 1 /Component 2	
Wilson		
1	Benzene / Dimethylacetamide [2]	84.9
2	Cyclohexanone / Benzene [3]	75.5
3	1-Pentanol / 1-Hexene [4]	75
4	1-Butanol / Aniline [5]	66.7
5	Acetaldehyde / Ethyl Acetate [6]	56.9
6	2-Pentanol / 1-Hexene [4]	56.3
7	Dimethyl Disulphide / Methanol [7]	45.3
8	2-butanol / Acetone [15]	43
9	Ethanol / Sec Butyl Acetate [8]	33.63
10	Dimethyl Disulphide / Ethanol [7]	31.63
11	2-propanol / Sec Butyl Acetate [8]	29.4
12	MIBK / 1-Propanol [9]	19
13	Cyclohexanone / p-Xylene [3]	17.2
14	n-hexane / 1,2- Dimethoxyethane [10]	17
15	Allyl Alcohol / Benzene [11]	16.9
16	1-propanol / Sec Butyl Acetate [8]	15
17	Methylcyclopentane / 1,2- Dimethoxyethane [10]	13.2
18	Dimethyl Disulphide / Propanol [7]	13
19	NN-Dimethylformamide / N, N-dimethylacetamide [12]	12
20	o-cresol / m-cresol [13]	12
21	o-cresol / 2, 6-dimethylphenol (2,6 Xylenol) [13]	12
22	Dimethyl Disulphide / Butanol [7]	7
23	Ethyl Benzene / p-xylene [3]	2.4
NRTL		
1	Cyclohexanone / Benzene [3]	75.5
2	1-Pentanol/ 1-Hexene [4]	75
3	1-Butanol / Aniline [5]	66.7
4	Acetaldehyde / Ethyl Acetate [6]	56.9
5	2-Pentanol/ 1-Hexene [4]	56.3
6	2-butanol / Acetone [15]	43
7	Ethanol / Sec Butyl Acetate [8]	33.63
8	1-Pentanol/ 1-2-4-trimethylbenzene(pseudocumene) [4]	31
9	2-propanol / N-Propyl Acetate [14]	19.4
10	MIBK / 1-Propanol [9]	19
11	Cyclohexanone/ p-xylene [3]	17.2
12	n-hexane/ 1,2-Dimethoxyethane [10]	17
13	NN-Dimethylformamide / N, N-dimethylacetamide [12]	12
14	o-cresol / m-cresol [13]	12
15	o-cresol/ 2, 6-dimethylphenol (2,6 Xylenol) [13]	12
16	2-propanol/ Iso-propyl Acetate [14]	6.4
17	m-cresol/ 2, 6-dimethylphenol (2,6 Xylenol) [13]	0

This study focuses on the impact of BIP's on the results of SCD, which was simulated in Aspen HYSYS and DWSIM for the systems mentioned in Table 1. The Wilson and NRTL thermodynamic packages were utilized for the simulation. SCD was performed thrice for each system, by using the following approach:

- SCD simulation without BIP's. (SCD-N)
- SCD simulation with BIP's estimated by Aspen HYSYS. (SCD-Est)
- SCD simulation with experimental BIP's from literature. (SCD-Exp)

The same methodology was used in DWSIM, but only for the NRTL model. To keep the simulation systems on a same reference, the feed streams to the SCD were specified as shown in Table 2. The inputs to the SCD column are shown in Table 3.

III. SIMULATION RESULTS

Based on the methodology discussed in the previous section, the simulation results are classified into two categories:

- Comparison of minimum reflux ratio (R_{min})
- Comparison of number of stages (N_a)

The values for R_{min} and N_a obtained using experimental BIP's were used as a reference for comparison.

Results obtained for systems simulated using Wilson showed significant deviations for both minimum reflux ratio and actual number of stages and are shown in Table 4, 5 and Fig. 1, 2.

The results obtained in DWSIM are shown in Table 7.

The results obtained clearly indicate that larger deviations were obtained while using Wilson as the thermodynamic model as compared to the NRTL model. The Average Absolute Deviation(%AAD) is evaluated on the basis of the following equation:

$$\%AAD = \frac{|(R_{min})_{exp} - (R_{min})_{wp/est}|}{(R_{min})_{exp}} \quad (1)$$

$(R_{min})_{exp}$ = Min reflux ratio considering experimental BIP's

$(R_{min})_{wp}$ = Min reflux ratio without considering BIP's

$(R_{min})_{est}$ = Min reflux ratio considering estimated BIP's

The Global % AAD's obtained for R_{min} and N_a for both Wilson and NRTL models are shown in Table 6.

$$\text{Global \% AAD} = \sum (\%AAD) / \text{Total no. of systems} \quad (2)$$

For NRTL based systems:

- Maximum %AAD for $(R_{min})_{wp}$ = 4.160688666
- Maximum % AAD for $(R_{min})_{est}$ = 15.0792205.
- Maximum % AAD for $(N_a)_{wp}$ = 2.489177489
- Maximum % AAD for $(N_a)_{est}$ = 12.09858103

For Wilson based systems:

- Maximum %AAD for $(R_{min})_{wp}$ = 93.3382012
- Maximum %AAD for $(R_{min})_{est}$ = 93.31081929
- Maximum % AAD for $(N_a)_{wp}$ = 91.91954
- Maximum % AAD for $(N_a)_{est}$ = 91.8930322

TABLE 2 Feed Stream Parameters

Feed Stream Specifications				
Vapour Phase Fraction	Pressure(kPa)	Molar Flow Rate(kmol/hr)	Mole Fractions	
			Component 1	Component 2
0 (Sat. Liquid)	101.325	100	0.5	0.5

TABLE 3 Distillation Column Inputs

Distillation Column Specification				
Mole fraction		Pressure(kPa)		Reflux Ratio (R_a)
Light key in distillate	Heavy key in bottoms	Condenser	Reboiler	
0.95	0.95	100	105	$R_a = 1.5 * R_{min}$

TABLE 4 Deviation from R_{min} Experimental for Wilson

System No	R_{min} Experimental	R_{min} Without Parameters	R_{min} Estimated
1	0.027	0.041	0.034
2	0.039	0.036	0.032
3	0.093	0.093	0.093
4	0.153	0.153	0.141
5	0.177	0.177	0.176
6	0.187	0.187	0.188
7	0.353	0.338	0.333
8	0.596	0.386	0.456
9	0.672	0.67	0.808
10	0.88	0.879	0.982
11	1.22	0.851	0.765
12	2.027	2.025	2.349
13	2.074	1.963	2.216
14	2.233	2.601	2.586
15	2.506	2.517	2.977
16	2.756	3.328	3.639
17	2.955	2.95	3.033
18	3.767	4.367	4.374
19	4.853	5.988	7.24
20	5.025	3.413	2.931
21	5.325	5.05	5.051
22	28.518	28.751	28.342
23	87.649	5.839	5.863

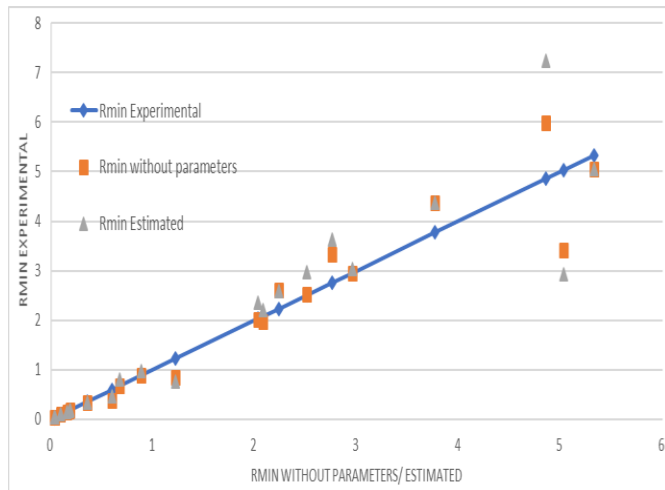

Fig 1. Deviation from Rmin Experimental for Wilson model (System 22,23 not shown due to very large deviation)

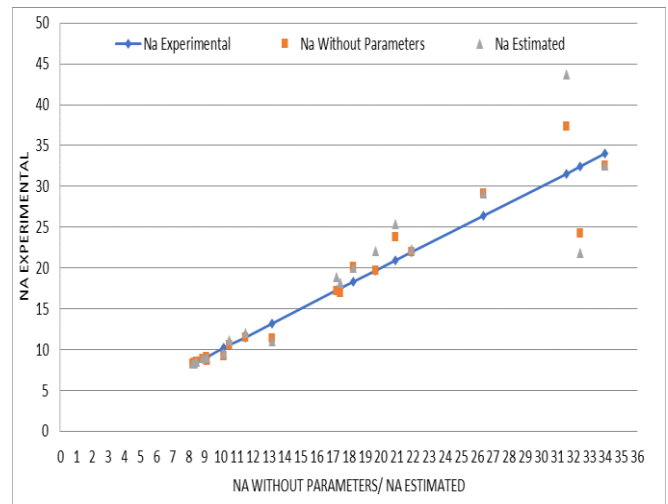

Fig 2. Deviation from Na Experimental for Wilson model (System 22,23 not shown due to very large deviation)

TABLE 5 Deviation from Na Experimental for Wilson

System No.	Na Experimental	Na without parameters	Na estimated
1	8.273	8.28	8.283
2	8.381	8.391	8.342
3	8.459	8.451	8.47
4	8.49	8.49	8.492
5	8.882	8.882	9.005
6	9.107	9.048	9.024
7	9.138	8.581	8.949
8	10.189	9.253	9.561
9	10.545	10.524	11.186
10	11.529	11.516	12.021
11	13.202	11.388	10.974
12	17.233	17.221	18.862
13	17.475	16.911	18.189
14	18.279	20.139	20.05
15	19.66	19.711	22.046
16	20.923	23.828	25.398
17	21.932	21.908	22.327
18	26.388	29.098	29.141
19	31.573	37.343	43.706
20	32.441	24.256	21.811
21	33.974	32.578	32.575
22	151.935	153.122	151.041
23	452.697	36.58	36.7

TABLE 6 Global %AAD

Global % AAD for Rmin and Na				
Without Parameters			Estimated Parameters	
	Rmin	Na	Rmin	Na
Wilson	14.60875323	9.069189949	19.23124835	11.96828419
NRTL	0.262201445	0.161712239	3.307086505	1.637033148

TABLE 7 Deviation from Na Experimental for NRTL in DWSIM

System No.	Na Experimental	Na without parameters
1	8.430	8.429
2	8.816	9.109
3	8.400	8.400
4	8.401	8.401
5	8.451	8.416
6	8.672	8.739
7	0*	0
8	12.627	12.415
9	15.806	15.812
10	19.299	19.299
11	28.276	28.290
12	0	0
13	26.566	26.567
14	0	0
15	0	0
16	36.843	43.147
17	0	0

*0 value indicates that the component was not found in the DWSIM component library

TABLE 8 Comparison of ASPEN HYSYS and DWSIM

Sr. No	Na(Exp) HYSYS	Na(Exp) DWSIM
1	8.273	8.430
2	8.849	8.816
3	8.459	8.400
4	8.394	8.401
5	8.483	8.451
6	9.051	8.672
7	10.693	0
8	17.411	12.627
9	16.038	15.806
10	17.556	19.299
11	21.881	28.276

12	20.11	0
13	29.118	26.566
14	32.577	0
15	36.691	0
16	34.814	36.843
17	340.082	0

TABLE 9 Binary Interaction Parameters for NRTL

System No	Aij	Aji
1	-2.031	10.656
2	0.171	0.475
3	31.98613767	0.38957935
4	-2.15	2.98
5	0.1692	0.40882
6	400.1290631	-123.5970363
7	-2.867351816	1.638384321
8	0.7801	2.5264
9	alpha(ij) = 0.3	alpha(ji) = 0.3
10	102.23	307.0807
11	0.328	5.036
12	0.49457457	-1.241921606
13	-0.446414914	1.027652964
14	alpha(ij) = 0.3	alpha(ji) = 0.3
15	alpha(ij) = 0.3	alpha(ji) = 0.3
16	alpha(ij) = 0.3	alpha(ji) = 0.3
17	alpha(ij) = 0.3	alpha(ji) = 0.3

TABLE 10 Binary Interaction Parameters for Wilson

System No	Aij	Aji
1	-290.6548757	968.0927342
2	-30.797	2.745
3	0.02636	0.1635
4	37.02676864	0.117112811
5	1.56	-6.24
6	0.0396	0.176
7	306.4125239	1594.978489
8	-222.0913002	492.91826
9	0.230162524	1.631692161
10	359.6199809	1113.659178
11	-0.225143403	1.083652008
12	605.0454	-193.8605
13	-28	3.79
14	0.034106119	0.119885277
15	-7.36	0.07
16	1.428776291	-2.633365201
17	-1.748135755	0.746391013
18	324.6725621	789.9474187
19	0.933221797	-0.289364245
20	-237.8134	169.1448
21	164.1672	-223.8732
22	338.5731358	589.2805927
23	0.0044	-0.0044

The results for shortcut distillation simulation obtained from both the simulators, i.e. Aspen HYSYS and DWSIM are obtained using the FUG (Fenske Underwood Gilliland) method. This makes it easier to compare the simulators. The BIP's used for simulation are shown in Table 9 and 10. The column is being operated at atmospheric pressure and therefore the gas phase is considered to be ideal.

IV. CONCLUSION

In the present work we worked on 40 systems which were simulated for SCD operation with WILSON and NRTL thermodynamic packages using Aspen HYSYS as the process simulator. DWSIM was used to simulate the 17 systems with NRTL.SCD simulation was carried out for three different cases, SCD-N, SCD-E.st and SCD-Exp in HYSYS and for 2 cases, SCD-N and SCD-Exp in DWSIM. The results indicate that BIP's have a significant impact on the results of the SCD simulation. The %AAD's obtained were significantly high, due to which there can be prominent errors encountered when simulating a rigorous distillation column by using the results obtained from SCD. From these results, the following observations have been made:

- Out of the 46 systems, only 6 systems had inbuilt BIP's in Aspen HYSYS, which is only 13%, which makes the study of their impact very crucial to avoid errors.
- Inclusion of BIP's are necessary while performing simulations. Therefore, one should be cautious and check for the availability of correct BIP's before performing simulations.
- Deviations obtained while using Wilson model were much higher than the deviations obtained while using NRTL model. The highest Global %AAD's for Wilson model were evaluated to be as high as 19% which can lead to enormous deviations in rigorous distillation simulations. Even though the deviations in NRTL model were small, use of proper BIP would increase the accuracy of the simulation.
- The systems with components having close boiling points resulted in high deviations while systems with components having a significant difference in boiling points resulted in small deviations.
- Components for system numbers 7,12,14,15,17 were not present in the DWSIM component library due to which their analysis was not performed. The rest of the systems showed significant deviations from the data obtained from Aspen HYSYS, due to which data validation for the results obtained from DWSIM is necessary.

REFERENCES

- [1] Carlson, E. C, "Don't Gamble with Physical Properties for Simulations", Chemical Engineering Progress. 92, 35-46,1996.
- [2] Wanliang Mi, Ruixin Tong, Chao Hua, Kai Yue, Debiao Jia, Ping Lu, and Fang Bai, "Vapor-Liquid Equilibrium Data for Binary Systems of N,N-Dimethylacetamide with Cyclohexene,

- Cyclohexane, and Benzene Separately at Atmospheric Pressure" *Journal of Chemical & Engineering Data* 60 (11), 3063-3068, 2015
- [3] Jun Gao, Kai Zhang, Dongmei Xu, Lianzheng Zhang, Nannan Chen, and Chunlu Li, "Isobaric Vapor-Liquid Equilibrium for Binary Systems of Cyclohexanone + Benzene, Cyclohexanone + Toluene, and Cyclohexanone + p-Xylene at 101.3 kPa" *Journal of Chemical & Engineering Data* 62 (7), 1948-1954, 2017.
- [4] Alejandro Moreau, José J. Segovia, M. Dolores Bermejo, M. Carmen Martín, "Vapor-liquid equilibria and excess enthalpies of the binary systems 1-pentanol or 2-pentanol and 1-hexene or 1,2,4-trimethylbenzene for the development of biofuels," *Fluid Phase Equilibria*. Volume 460, 85-94, 2018.
- [5] Mehran Alinejhad, Alireza Shariati, and Javad Velayati, "Experimental Vapor-Liquid Equilibria and Thermodynamic Modeling of the Methanol + n-Heptane and 1-Butanol + Aniline Binary Systems" *Journal of Chemical & Engineering Data* 63 (4), 965-971, 2018.
- [6] Huanhuan Sun, Cheng Liu, Zhongfeng Geng, Yang Lu, and Yixuan Chen, "Isobaric Vapor-Liquid Equilibrium for Three Binary Systems of Acetaldehyde + Ethanol, Ethyl Acetate, 1-Butanol at 101.3 kPa" *Journal of Chemical & Engineering Data* 62 (7), 2136-2142, 2017.
- [7] Najla Ben Mahdoui, Hector Artigas, Carlos Lafuente, Monia Hichri, and Ismail Khattech, "Isobaric Vapor-Liquid Equilibrium for the Binary Systems Dimethyl Disulfide + C1-C4 n-Alkanol at 40.000 and 101.325 kPa" *Journal of Chemical & Engineering Data* 62 (7), 2037-2043, 2017.
- [8] Zhankun Jiang, Fengjiao Zhang, Xueying Zhu, Hongqi Ai, YuChuan Li, Zhonghe Chen, Jing Fang, Guoxin Sun, and Cheng Yang, "Isobaric Vapor-Liquid Equilibrium for the Binary Systems of Secbutyl Acetate and Ethanol, 1-Propanol, or 2-Propanol at 101.3 kPa" *Journal of Chemical & Engineering Data* 62 (11), 3697-3702, 2017.
- [9] Funmilola Avoseh, Samuel A. Iwarere, Caleb Narasigadu, and Deresh Ramjugernath, "Vapor-Liquid Equilibrium for Methyl Isobutyl Ketone (MIBK) + (1-Propanol or 2-Propanol) Binary Mixtures" *Journal of Chemical & Engineering Data* 62 (7), 2014-2020, 2017.
- [10] Yin Hai Sun, Dianliang Fu, Shoutao Ma, Zhanhua Ma, and Lanyi Sun, "Isobaric Vapor-Liquid Equilibrium Data for Two Binary Systems n-Hexane + 1,2-Dimethoxyethane and Methylcyclopentane + 1,2-Dimethoxyethane at 101.3 kPa" *Journal of Chemical & Engineering Data* 63 (2), 395-401, 2018.
- [11] Jing Li, Chao Hua, Shuai Xiong, Fang Bai, Ping Lu, and Jiayi Ye, "Vapor-Liquid Equilibrium for Binary Systems of Allyl Alcohol + Water and Allyl Alcohol + Benzene at 101.3 kPa" *Journal of Chemical & Engineering Data* 62 (10), 3004-3008, 2017.
- [12] Xuemei Zhang, Wei Yang, Hongpeng Liu, Chungui Jian, "Isobaric Vapor-Liquid Equilibrium for Binary System of N, N-dimethyl formamide þ N, N-dimethyl acetamide and quaternary system of secbutyl alcohol þ sec-butyl acetate þ N, N-dimethyl formamide þ N, N-dimethyl acetamide at 101.3 kPa" *Fluid Phase Equilibria* 0378-3812, 2015.
- [13] Jun Wang, JieOu, Xueni Sun, Chunxiang Huang, Jiarui Sun, Hui Shao, YixinLeng, "Measurement and correlation of isobaric vapour-liquid equilibrium for systems of o-cresol, m-cresol and 2, 6-dimethylphenol at 20.0 kPa" *Fluid Phase Equilibria*, Volume 459, 44-50, 2018.
- [14] Filipa M. Casimiro, Dânia S. M. Constantino, Carla S. M. Pereira, Olga Ferreira, Alfrío E. Rodrigues, and Simão. P. Pinho, "Vapor-Liquid Equilibrium of Binary Mixtures Containing Isopropyl Acetate and Alkanols at 101.32 kPa" *Journal of Chemical & Engineering Data* 60 (11), 3181-3186, 2015.
- [15] Michalski H.; Michalowski S.; Serwinski M.; Strumillo C, "Vapour - Liquid Equilibria for the System Acetone - n-Butanol" *Zesz.Nauk.Politech.Lodz.Chem.* 36, 73-84, 1961.

Multicomponent Distillation and its Sequencing Using DWSIM

Sameer Imdad
dept. of Petroleum Studies(ZHCET)
Aligarh Muslim University)
Aligarh, India
sameerimdad87@gmail.com

Aamir Baig
dept. of Petroleum Studies(ZHCET)
Aligarh Muslim University)
Aligarh, India
aamirbaig001@gmail.com

Mohd Mohsin Ikram
dept. of Petroleum Studies(ZHCET)
Aligarh Muslim University)
Aligarh, India
mohdmohsinikram@gmail.com

Abstract—The objective of this work is to design a multicomponent distillation column and its sequencing with the help of DWSIM software in which organic mixture containing ethane, propane, n-butane, n-pentane and n-hexane having molar composition 5, 25, 30, 20 and 20 in percentage respectively with basis of feed 100 Kmole/hr in which the recovery of 95 percent propane in the distillate (light key) and 90 percent recovery of n-butane (heavy key) from the bottom was performed. The feed is coming from the Atmospheric distillation unit (ADU) at the atmospheric pressure, this is in vapour liquid to handle this feed in the distillation column the pressure is applied and increased up to 5 bar. Heuristics were applied in order to obtain the best sequence for optimization. The most optimized sequence and the possible sequence while using DWSIM was AB/CDE, C/DE, A/B, and D/E by simply using shortcut distillation column followed by rigorous distillation column in DWSIM. The top and bottom products will be the feed for the next distillation columns and hence sequencing of distillation column takes place with optimized sequencing.

Keywords—sequencing, distillation, DWSIM, optimization

I. INTRODUCTION

In day-to-day life, the challenges in the field of chemical engineering process design, the process should be economically feasible and profitable. Distillation is one of the oldest and conventional methods for separation of several components in a mixture. Distillation is a separation process which uses boiling point difference as a tool to distinguish between components and makes them separable at their respective boiling points. Distillation column is defined as equipment used to separate components of a mixture on the basis of thermodynamic properties of the components [1]. The components whose distillate and bottoms fractional recoveries have to be determined are called key components. The most volatile of the keys is called the light key (LK) and the least volatile is called the heavy key (HK). The other components are called non-keys (NK). Light non-key (LNK) is referred when non-key is more volatile than the light key whereas heavy non-key (HNK) is less volatile than the heavy key. The main part of the distillation column comprises trays, condenser and reboiler. The column stages where exchange of liquid and vapour takes place can be calculated with the help of Fenske-Underwood-Gilliland method (FUG). When feed is entered into the column at feed tray it divides the column in two sections, namely top section (absorption/enriching/rectification) and a bottom section (stripping/exhausting). Components with higher temperature will lie at the bottom section and the lower temperature will come out from the

top because liquid and vapours are always at their bubble and dew points inside the column. The dew-point is the temperature at which the saturated vapour starts to condense whereas bubble-point is the temperature at which the liquid starts to boil. The feed is coming from the Atmospheric distillation unit (ADU) at the atmospheric pressure, this is in vapour liquid to handle this feed in the distillation column the pressure is applied and increased up to 5 bar. And the compositions of the feed are ethane, propane, n-butane, n-pentane and n-hexane which are needed to be separated in the distillation column. To get the initial estimates of the distillation column, Fenske Equation is used to determine the minimum number of trays required for a given separation. And for calculating minimum reflux ratio Underwood's equation should be used for the given separation which later followed by Gilliland equation to find the number of theoretical trays for the process. Since this multicomponent distillation sequencing is to be optimized, there should be some heuristics to be applied to make the process feasible. There are several heuristics given for various processes out of which only four were used are given as: *Heuristic 1*. Separations where the relative volatility of the key components is close to unity or that exhibit azeotropic behaviour should be performed in the absence of non-key components. In other words, do the most difficult separation last. *Heuristic 2*. Sequences that remove the lightest components alone one by one in column overheads should be favoured. In other words, favour the direct sequence. *Heuristic 3*. A component composing a large fraction of the feed should be removed first. *Heuristic 4*. Favour splits in which the molar flow between top and bottom products in individual columns is as near equal as possible [2].

There also exists an equation to generate the possible sequences for desired number of products $N_s = \frac{(2(P-1))!}{P!(P-1)!}$ where N_s is the number of sequences and P is the number of products [3]. In our case of five product system, four simple columns are needed for the 14 possible sequences out of which only single sequence with feasible conditions would be taken as the final sequence. However, before sizing and costing calculations can be carried out, the pressure must be also specified. Pressure is a critically important optimization variable, and the appropriate pressure is not known until optimization calculations have been carried out. If the pressure can vary continuously during the optimization then nonlinear optimization will have to be carried out as the sizing and costing equations are nonlinear. However, it is desirable to avoid nonlinear optimization if possible.

Instead, the pressure of each task and each hybrid task can be chosen to operate only at discrete pressures.

II. CALCULATIONS

A. Distribution of components

Distillation is the most common method used to separate homogeneous mixture of feed, so the feed will be separated into various product rather than two by-products like in case of binary distillation column. The given below mixture must be separated by distillation such that 95% of the propane is recovered in the distillate and 90% of the butane is recovered in the bottoms (for a column operating at 5 bar) as shown in Table 1 [2].

By applying material and component balance the following distillate and bottom composition should be calculated. In this calculation assumption were made that no lighter than light key in bottom and heavier than heavy key in distillate. By Applying Material balance and Component balance the values of y_D and x_W shown in Table 2. of different components. Distillate and Bottoms are found to be 31.75 kmol/hr and 68.25kmol/hr.

TABLE 1

S.No	Table Column Head		
	Component	Formula	Feed
1	Ethane	C2H6	5
2	Propane	C3H8	25
3	n-Butane	C4H10	30
4	n-Pentane	C5H12	20
5	n-Hexane	C6H14	20

TABLE 2

Calculation for distillate and bottom composition						
Components	Feed,F		Distillate,D		Bottoms,W	
	x_F	$x_F F$	y_D	$y_D D$	x_w	$x_w W$
A	0.05	5	0.1653	5	0.0000	0
B(lt. Key)	0.25	25	0.7851	23.75	0.0183	1.25
C(hy. Key)	0.3	30	0.0496	3	0.3956	27
D	0.2	20	0.0000	0	0.2930	20
E	0.2	20	0.0000	0	0.2930	20
Total		100	1.0000	31.75	1.0000	68.25

TABLE 3

Calculation for dew point temperature				
Components	y_D	$K_i(270K)$	α_i/butane	y_i/α_i
A	0.16589	3.6	17.14286	0.0096419
B(lt. Key)	0.78512	1.09	5.190476	0.1512624
C(hy. Key)	0.04958	0.21	1	0.0495868
D	0	0.045	0.214286	0
E	0	0.015	0.071429	0
			$K_c = 0.21049$	

TABLE 4

Calculation for bubble point temperature				
Components	x_w	$K_i(328K)$	α_i/butane	$x_i \alpha_i$
A	0.0000	8.70000	41.42857	0

B(lt. Key)	0.0183	3.15000	15	0.274725
C(hy. Key)	0.3956	1.39000	1	0.395604
D	0.2930	0.37500	1.785714	0.523286
E	0.2930	0.14500	0.690476	0.202337
			$K_c=1.3959$	

B. Bubble Point Temperature

The bubble point is the temperature (at a given pressure) where the first bubble of vapor is formed when heating a liquid consisting of two or more components. By taking n-butane as our base component, calculating the dew point temperature at 270 K. Bubble point temperature was calculated by using the formula:

$$\sum(z_i * k_i) = 1 \quad (1)$$

Calculate the bubble point temperature by using the formula $\sum z_i * K_i = 1$ by trial and error process, the temperature of mixture is assumed and the value of z_i is calculated from the value of K_i at 270 K [4]. The values of K_i get from graph between K_i vs T and finally get the bubble point temperature as $T = 296.366$ K.

C. Dew Point Temperature

Dew point is the temperature to which air must be cooled to become saturated with water vapor. When further cooled, the airborne water vapor will condense to form liquid water. Dew point was calculated using the formula:

$$\sum z_i / K_i = 1 \quad (2)$$

Similarly calculate the values of dew point, by trial and error process, the temperature is assumed and the value of z_i is calculated from the value of k_i at 270K [4]. Calculate the values of k_i from the graph k_i vs T and finally the bubble point temperature is 359.105 K. Relative volatilities of components in the organic mixture $\alpha_i = k_i/k_j$, Where k_j is heaviest component in the organic mixture α_{LD} is light key at the top(dew point) and α_{LW} is the heavy key at the bottom temperatures.

D. For calculating Minimum number of trays by using Fenske Equation

Minimum number of trays for multi-component distillation at total reflux can be calculated using Fenske equation. The derivation was based on the assumptions that the stages are equilibrium stages (Fig. 1). Consider a multi-component distillation column operating at total reflux as shown.

On assuming a total condenser and the relative volatility being constant up the column for two components i and j, the number of theoretical stages at total reflux and is known as Fenske Equation [5]. Where i is the Light key component and j is the heavy key component and taking their recoveries in distillate and bottom into consideration, calculate the value of N_{min} with reference to the heavy key component. N_{min} can also be calculated using the following equation:

$$N_{min} = \frac{\log\left(\frac{x_D}{1-x_D} \times \frac{1-x_W}{x_W}\right)}{\log \alpha_{av}} \quad (7)$$

$$\alpha_{av} = (\alpha_L * \alpha_W)^{0.5} \quad (8)$$

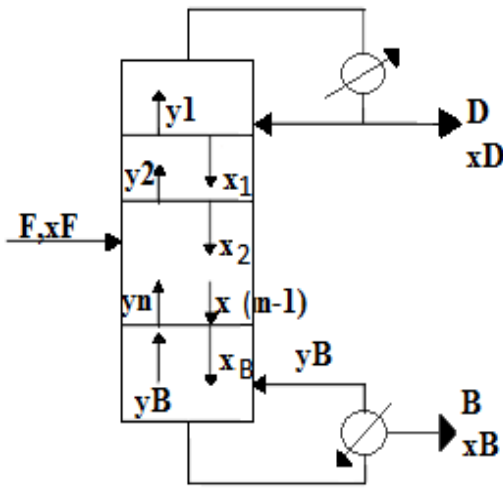

Fig. 1 Multi-component column at minimum trays

Where N_{min} is the minimum number of trays x_D is % recovery of Light Key in the distillate, x_W is % recovery of Heavy Key in the Bottom, α_{av} is relative volatility between light and heavy key component, α_l is relative volatility of overhead vapor, α_w is relative volatility of bottom liquid. By putting all the values in Fenske's equation the value of N_{min} is 4.20 theoretical trays and 5.20 stages due to reboiler.

E. For Calculating Minimum Reflux Ratio by using Underwood Equations

For multi-component systems, if one or more of the components appear in only one of the products, there occurs a separate pinch point in both the stripping and rectifying sections. In this case, Underwood developed an alternative analysis to find the minimum reflux ratio [5]. The minimum reflux ratio is determined by Underwood equations as follows below:

$$1-q = \sum_i^{NC} \frac{\alpha_i x_{iF}}{\alpha_i - \theta} \quad (5)$$

$$R_{m+1} = \sum \frac{\alpha_i x_{iD}}{\alpha_i - \theta} \quad (6)$$

Where $\alpha_{i,j}$ is relative volatility, $x_{i,F}$ is mole fraction of component in the feed θ is root of the equation, q is feed condition (saturated feed = 1) N_C is number of component Underwood's equations were used at Minimum reflux conditions to determine the minimum reflux ratio, using two equations (5) and (6). Assuming Θ to be 2.71 and at this value finally Minimum Reflux Ratio is $R_{min} = 0.4299$

F. Gilliland Equation

The flow factor and the tray space are calculated, and the column is operated at 85% of the flooding capacity, the number of theoretical trays is then calculated by Gilliland equation [6]. Gilliland used an empirical correlation to calculate the final number of stage N from the values calculated through the Fenske and Underwood equations (N_{min} , R , R_{min}).

TABLE 5

Theoretical number of stages(N) using Gilliland correlation:		
$Y=0.2788-1.3145X+0.4114X^2+0.2910+0.8268.\ln X+0.9020\ln(X+1/X)$		
$Y=(N-N_{min})/(N+1)$	$X=(R-R_{min})/(R+1)$	$R=1.25 \cdot R_{min}$
0.477488	0.15344	3.29554405

The overall equations for these methods are given as follows:

$$\frac{N-N_{min}}{N+1} = 1 - e \left[\frac{1 + \frac{54.4(R-R_{min})}{(R+1)}}{11 + \frac{117.2(R-R_{min})}{(R+1)}} \times \frac{R-R_{min}}{\left[\frac{(R+1)-1}{(R+1)} \right]^{0.5}} \right] \quad (9)$$

Θ (To be assume) = 3.16295, Now the theoretical Number of stages using Gilliland correlation. From the above equation of Gilliland correlation, the value of Theoretical number of stages N is 11

G. Using Kirkbride Equation

Kirkbride has devised an approximate method to estimate the number of theoretical stages above and below the feed which can be used to estimate the feed – stage location. The Kirkbride equation is given as follows:

$$N_R / [B/D ((x_{H,i})/(x_{L,F}))((x_{L,B})/(x_{H,D}))^2]^{0.206} \quad (10)$$

By putting all the values in above equation, the values of N_R and N_S is as Follows: $N_R = 5$, $N_S = 6$

H. Antoine Equation

The Antoine equation is a semi-empirical correlation describing the relation between vapor pressure and temperature for pure components.

$$K_i = \frac{1}{P} e^{[A_i - \frac{B_i}{C_i + T}]}$$

Where P is system operating pressure in bar and T is the guess temperature (bubble or dew point temperature) A , B , C are the Antoine's constants at fixed temperature and pressure for respective components A , B , C values for Ethane, propane, n-butane, n-hexane, n-heptane as shown in Table 6[2]. The remaining values including those values of x_W and y_D which were assumed earlier as zero were calculated as shown in Table 7

TABLE 6

Antoine's constants for given system			
Comonents	Ai	Bi	Ci
C2	9.0435	1511.4	-17.16
C3	9.1058	1872.5	-25.16
C4	9.058	2154.9	-34.42
C5	9.2131	2477.1	-39.94
C6	9.2164	2697.6	-48.78

TABLE 7

Distribution of Components						
Comonents	Feed,F		Distillate,D		Bottoms,W	
	x_F	x_{FF}	y_D	y_{DD}	x_W	x_{WW}
A	0.05	5	0.1653	4.999	0.0000	0.0001

B(lt. Key)	0.25	25	0.7851	23.75	0.0183	1.25
C(hy. Key)	0.3	30	0.0496	3	0.3956	27
D	0.2	20	0.0000	0.0064	0.2930	19.9935
E	0.2	20	0.0000	0	0.2930	20
		100	1.0000	31.756	1.0000	68.2436

$$\alpha_{L,av} = \sqrt{\alpha_{LD} \cdot \alpha_{LW}} \quad (12)$$

$$\alpha_{L,av} = 3.399809, \alpha_{A,av} = 12.18965005, \alpha_{D,av} = 0.325029$$

$$x_{AD}D/x_{AW}W = 49513.6358, x_{DD}D/x_{DW}W = 0.000321$$

$$x_{AW}W = 0.00010098, x_{DW}W = 19.99358, x_{AD}D = 4.9998$$

$$x_{DD}D = 0.00642$$

I. Determination of Column Efficiency and Height

Efficiency of the column was estimated using the equation,

$$E_o = 0.542 - 0.285 \log(\alpha_{LH} \cdot \mu_L) \quad (13)$$

where, E_o is the overall stage efficiency ($0 < E_o < 1$), α_{LH} is the relative volatility between the key components and μ_L is viscosity of the feed at average column conditions ($\text{mNsm}^{-2} = \text{cP}$). By putting all the values in above equation, Column Efficiency (E_o) and N_R is 0.83 and 13.16 respectively

$$H = C(N_R - 1) + C_T \quad (14)$$

Where H is the height of the column (m), C is the plate spacing (m) and C_T is the Allowance at the Top By putting all the values in above equation, the column height to be 9.47 m

J. Determination of the column diameter

The flow factor was calculated as well as the tray space and the column were considered to be operated at 85% of the flooding capacity [3]. The column down-comer, net, and active areas were specified as well as the diameter of the column at 85% of the flooding velocity. Initially the liquid and the vapor flow rate above and below the feed were determined, followed by the determination of liquid-vapor flow parameter.

$$F_{L,V} = \left(\frac{M_L L}{M_V V}\right) \left(\frac{\rho_V}{\rho_L}\right)^{0.5} \quad (15)$$

The vapor flooding velocity is determined assuming a foaming fraction of 0.9 and with the terminal velocity parameter K_T

$$V_T = 0.9 K_T \left(\frac{\rho_V}{\rho_L}\right) \quad (16)$$

Where, L is liquid molar flow rate ($\text{kmol} \cdot \text{s}^{-1}$), V is vapor molar flow rate ($\text{kmol} \cdot \text{s}^{-1}$) $F_{L,V}$ is liquid vapor flow

TABLE 8

Flowrates of liquid and vapor from top	
Distillate flowrate(Kmol/hr), D	31.75
$V_{TOP} = D(R+1)$	143.07
$L_{TOP} = R \cdot D$	111.32
L_{bottom}	211.32
V_{bottom}	74.834

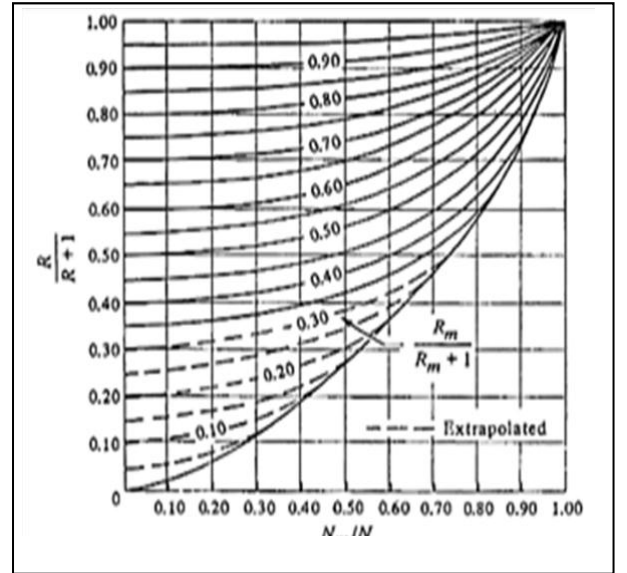

Fig.2 Erbar-Maddox correlation between reflux ratio and number of stages

Parameter M_L is liquid molar mass, M_V is vapor molar mass, ρ_V is vapor density, ρ_L is liquid density (kg m^{-3}).

To obtain the column diameter, an allowance must be made for down comer area (say 10%), and the vapor velocity

$$\text{Diameter} = \left(\frac{4M_V V}{0.9 \cdot 0.8 \cdot \pi \cdot \rho_V \cdot V_T}\right) \quad (17)$$

By Putting the values in above equation, the Column diameter is $\text{DIA}_T(\text{m})$ to be 0.58 and $\text{DIA}_B(\text{m})$ to be 0.68. The diameter was then determined for the top and bottom of the distillation column with respect to its flow rate parameters and terminal velocity parameters at the top and bottom of the column respectively. Verification of calculation could be verified by using Erbar-Maddox Correlation curve (Fig. 2).

III. SIMULATION USING DWSIM

A. Introduction

It is very difficult to produce results manually while designing multicomponent distillation column. And moving from shortcut method to rigorous method for distillation column, it is nearly impossible for a person to perform so many calculations. Hence there is a need for computer aided software to perform hundreds of iterations and obtain result in a finite time. DWSIM software was used which is an open-source CAPE-OPEN compliant chemical process simulator. It allows to conduct experiments and analyse data using advanced models and operations. The simulator allows to run the simulations and get a better understanding on a phenomenon. It has built-in thermodynamic models and unit operations as well as a large range of tools for managing reactions or creating components. Some popular property packages are also available, from which Peng-Robinson property was used by considering the pressure of 5 bars as stated in the problem. The simulator is preloaded with loads of information regarding various components which allows us

to view the properties of the pure component, calculate the critical point, perform hydrate calculations, as well as conduct the sensitivity analysis and multi-variate optimizations. DWSIM is capable of generating distillation curves petroleum characterizations and helps us to create new compounds that can be used in experiments, along with the existing ones. Also, it can be used for performing data regression studies for two compounds using various thermodynamics models and methods, generating conclusive graphs.

B. Procedure

Selection of organic components from the library of the simulator was made by searching ethane, propane, n-butane, n-pentane, and n-hexane. Peng-Robinson property was chosen from the package along with the algorithm loop and the system of units. Shortcut column was selected and placed to the designing field such that it should be in the center and material streams and energy streams can easily be connected to it. The basis of feed would be 100 Kmol/hr. Connections of material and energy streams to the distillation column were made. Propane and n-butane were taken as the lighter and heavier keys. Put the mole fraction of light key and heavy key in the bottom and the distillate respectively (Fig.3). These preliminary observations would be required by the rigorous column as its input. Delete the shortcut column and replace it with a rigorous column where the required input is to be fed. The useful parameters which were calculated using shortcut column and required by rigorous column are as follows:

- Minimum reflux ratio
- Minimum number of stages
- Actual number of stages
- Optimal feed stage
- Bottom product rate

C. Multicomponent Distillation sequencing

In the previous sections, designing of shortcut column and rigorous column for multicomponent organic mixture was performed for a single arrangement. For optimizing the multicomponent distillation sequence, it is therefore needed to arrange the distillation column in such a way that first column will be the feed for the second column which will be

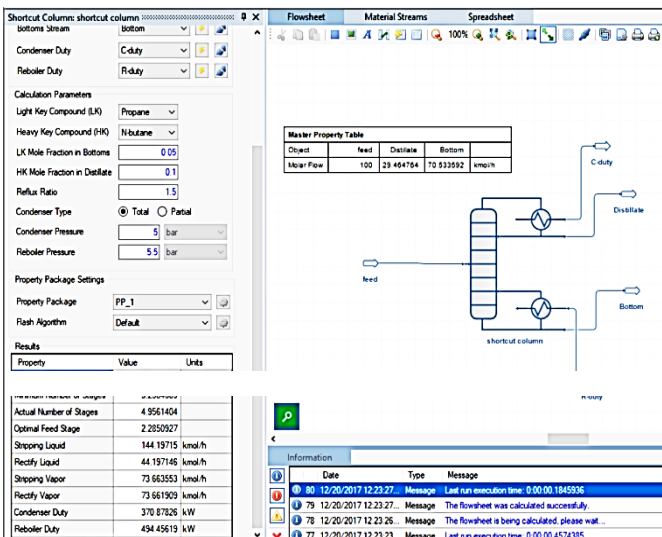

Fig. 3 Designing of shortcut column

the feed for third and fourth column (Fig. 4). This is the first sequence in which propane is recovered 95% in the distillate and 90% n-butane in the bottoms. Similar to this, 13 more sequences were performed and found to be inefficient while considering the heuristics. It is impossible to show those 13 sequences in this paper. The possible optimized sequence was found to be AB/CDE, C/DE, A/B, D/E.

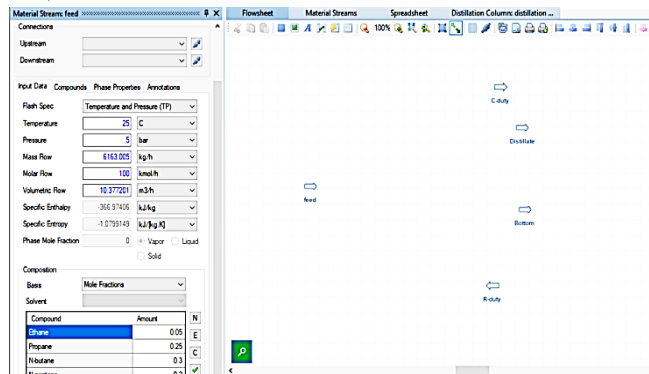

Fig. 4. Deleting Shortcut Column only

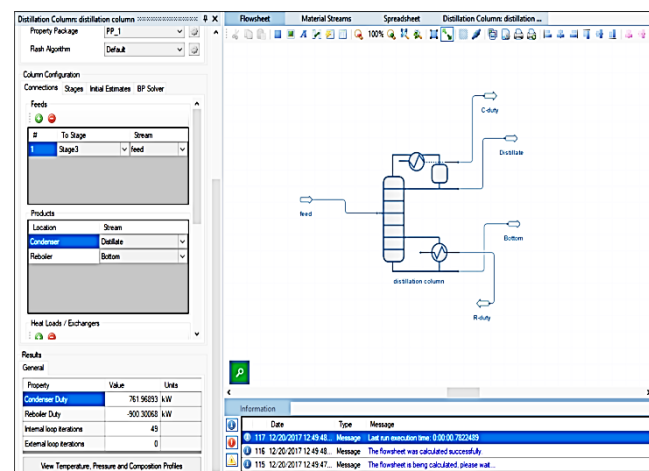

Fig. 5 Rigorous method for distillation column

IV. RESULT

After performing simulation using DWSIM it was found that the distillate and bottom flowrates as shown in Fig. 6 was nearly similar as compared with the calculations performed manually by using excel spreadsheets. Also, the minimum reflux and number of stages were found nearly

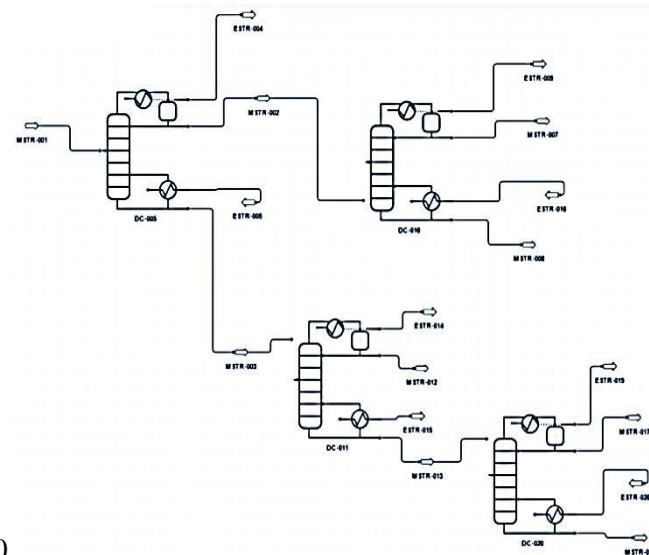

Fig. 6 Multicomponent assembly of distillation column using rigorous method

TABLE 9

Master Property Table for Molar Flow by DWSIM				
Object	M-018	M-017	M-013	M-012
Molar Flow (Kmol/h)	68.77	0.6682	69.44	1.0882
M-008	M-007	M-003	M-002	M-001
1.1356	28.33	70.53	29.46	100
Master Property Table for Energy Flow				
Object	E-004	E-005	E-009	E-010
Energy Flow (KW)	231.99	-349.53	1280.44	-1282.4
E-014	E-015	E-019	E-020	
12.40	-13.72	20.32	-21.14	

TABLE 10

Distillation columns data by DWSIM after sequencing				
Distillation Columns	DC-020	DC-011	DC-010	DC-005
Reflux Ratio	4.986	1.247	7.999	0.536
Distillate Molar Flow (kmol/h)	0.668	1.088	28.330	29.468
Number of Stages	5	6	11	10

equal which were 0.43 and 11 respectively. Condenser and reboiler duty was calculate using DWSIM are shown in table 8

V. CONCLUSIONS

The organic mixture of ethane, butane, n-pentane and n-hexane with propane being the lighter key component and butane being the heavy key component, was decided on the basis of heuristics. The bubble point and dew point of feed were found to be 296.366 K and 359.105 K by using Antoine's equation at fixed pressure 5 bar. For calculating top and bottom temperature of components it was found to be 270 K and 328 K respectively. Using Fenske's equation the minimum number of stages were 5.2 which is taken as 6.0. After the determination of minimum number of stages, proceed further to find the amount of the volume fraction of the lighter than light key and heavier than heavy key components which were assumed to be 0 in the first trial which turn out to be 4.999 in the distillate (ethane), 0.0001 in the bottoms (ethane), 0.006424 in the distillate (n-pentane) and 19.99358 in the bottoms (n-pentane).

The minimum reflux ratio was calculated with the help of underwood's equation which was found to be 0.4299 by making several trials to find the value of Θ which comes out to be 2.71 at the average temperature of 327.73K. The actual reflux ratio is to be chosen as 1.25 times the minimum reflux ratio due to the economic aspects and the optimization of distillation process. This reflux ratio gives the theoretical number of stages to be 11 with the help of Gilliland correlation. Overall efficiency of the column was found to be 0.835 and the number of real trays to be 13.16. Since the organic mixture may results in excess foaming, taking the plate spacing 0.45m which gives the height of the column to be 9.4758 m. After finding the height calculate

the distillate flowrate in the stripping and rectifying section. The flow parameter of top and bottom section was calculated which gave diameter of the column of top and bottom to be 0.58m and 0.68m respectively.

By using Kirkbride equation the number of trays in rectifying section and stripping section were found to be 5 trays and 6 trays respectively. Since it was cross checked by Erbar-Maddox correlation between reflux ratio and number of stages results to be 10.5 which is quite closer to calculated value of number of stages 11. At pressure of 10 bar for the same problem gives number of stages 17 [3] because increase in pressure results in relative volatility decrease so for the same purity of product more stages required. So height of distillation column will increase.

Multicomponent separation systems are found in widespread use in the chemical and petroleum industries. An important process design problem in multi component separations is the separation sequencing, which is concerned with the selection of the optimal method and sequence for the separation. Hendry and Hughes introduced the separation task concept, where the distillation network is decomposed into the individual separation tasks, which are evaluated using the ideal thermodynamic based Underwood-Fenske-Gilliland method. The major problem with column sequencing is the large number of possible sequences, which grows exponential by the number of products. The number of possible sequences for a desired number of products is given by $N_s = \frac{(2(P-1))!}{P!(P-1)!}$. This contribution presents a stepwise procedure to identify the optimal sequence. This problem is often solved by first arranging the components in the mixture to be separated in some ranked lists of appropriate physical and/or chemical properties such as relative volatility. All 14 sequences were performed, but the most optimized sequence and the possible sequence while using DWSIM was AB/CDE, C/DE, A/B, D/E.

VI. REFERENCES

- [1] Brooks, B. A. (1993). Modeling of a Distillation Column Using Bond Graphs, M. Sc. Thesis, University of Arizona, 70-88
- [2] Smith, R. (2005). Chemical process design and integration (Second ed.). Chichester, West Sussex, United Kingdom: John Wiley & Sons. Inc.
- [3] Thirumalesh, B.S. Ramesh, V. (2015). Case Study on Multicomponent Distillation and Distillation Column Sequencing. International Journal of Engineering Sciences & Research Technology, 609-623
- [4] Perry, R. H., Green, D. W., & Maloney, J. O. (1997). Perrys chemical engineers handbook. New York, NY: McGraw-Hill.
- [5] Geankoplis, C. J. (2015). Transport processes and separation process principles: (includes unit operations). New Delhi: Prentice Hall of India.
- [6] Gilliland, E. R. (1940). Multicomponent Rectification Estimation of the Number of Theoretical Plates as a Function of the Reflux Ratio. Industrial & Engineering Chemistry, 32(9), 1220-1223. doi:10.1021/ie50369a035

Chapter 2

Flowsheets

In this chapter, we provide a brief summary of 100 flowsheets, created mainly by students and faculty of top chemical engineering departments in India. All of them have been solved using the state of the art Free and Open Source Simulator (FOSS) DWSIM. Most of them have also compared their results with that from a commercial equivalent. We have also given a link for every flowsheet, from which, one may download and make use of the flowsheet.

About a year ago, we wrote to all chemical engineering departments, numbering about 350 in India, and asked them to learn DWSIM, solve any flowsheet and offer them for sharing. We created Spoken Tutorials on DWSIM, using which, one can self-learn the software. Many students responded to this invitation and helped create the flowsheets reported in this chapter.

The process of contributing is straight forward. One can visit <https://dwsim.fossee.in>, log into the system, and express their desire in participating in the flowsheet project. If the flowsheet is a reasonable one and provided it is not already solved by someone else, the FOSSEE team approves it. But for this, the flowsheet can be from any source: textbooks, research papers, other simulators, from industry, etc.

Once a flowsheet meets the above requirements, it gets approved. Students are expected to complete the flowsheet in a reasonable time using DWSIM after the approval. They have to upload their flowsheets on to our portal. Each flowsheet gets reviewed by the FOSSEE team for correctness and to check how it compares with published data, or with other simulators, or with lab data. After this process, the flowsheet is released under the CC license CC-BY-SA. Every participant gets a honorarium, a certificate and a mention on our website.

These flowsheets are arranged in the same order as it appears on the flowsheeting project of FOSSEE, namely <https://dwsim.fossee.in/flowsheeting-project/completed-flowsheet>. On this URL, we generally arrange the flowsheets in the order they are approved to be uploaded.

As mentioned earlier, we have selected flowsheeting through a FOSS process simulator DWSIM to improve the employment potential of our students in core industry and to provide trained professionals to the industry, especially those in small and medium companies. For a countrywide training, use of FOSS simulator is apt, as commercial simulators will be prohibitively expensive. FOSS simulators are also useful to small scale industry, which also cannot afford expensive simulators. Using FOSS simulators is any day better than not using any simulator at all.

Using Spoken Tutorials <https://spoken-tutorial.org>, we can easily train a large number of students from all chemical engineering departments how to use a FOSS chemical process simulator. We can easily accommodate students from tier 3 and tier 4 colleges as well, in this effort. Small and medium scale companies, on the other hand, have difficult in finding well trained man power. We hope to bridge this gap through our FOSSEE project in general and FOSS simulator project in particular. Students trained on the use of DWSIM, for example, can be of use to the chemical industry. If they can carry out material and energy balance,

The 100 flowsheets presented in this chapter demonstrate the benefits of collaboration amongst the community. These flowsheets cover a variety of topics, exhibiting the capability of the simulator DWSIM.

The fact the results match with those from commercial simulators will increase the confidence level of industry. At the time bidding for a project, engineering companies may find our collection useful to get a first cut answer. These simulations may also be useful in a chemical engineering course, such as Chemical Technology.

We hope that you can invite your colleagues/students to participate in the DWSIM based flowsheeting project.

2.1 Nitrogen Liquefaction using Linde Cycle

Author: Priyam Nayak

Institution: Indian Institute of Technology Bombay

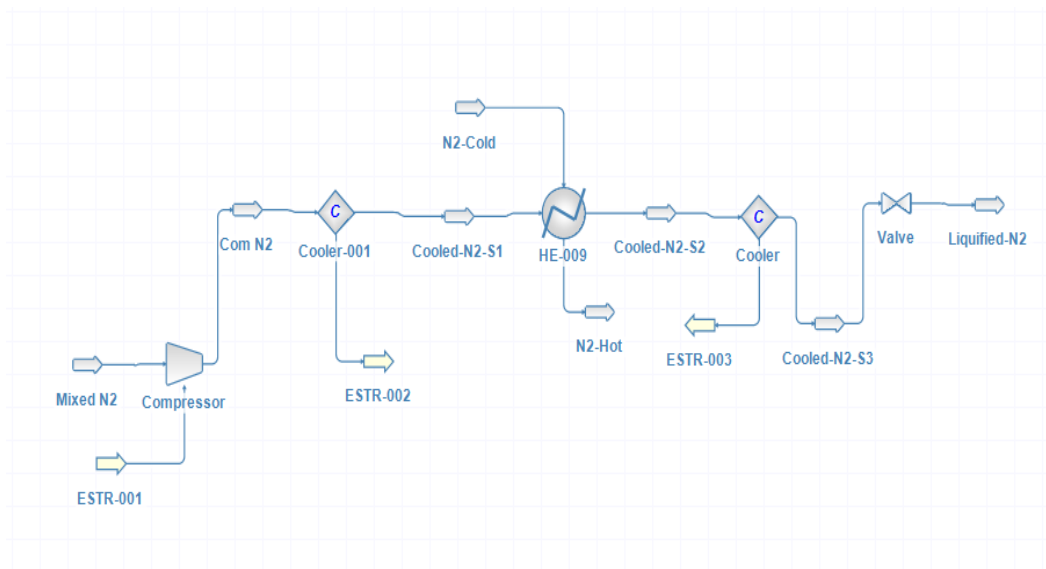

A process for gas liquefaction, particularly nitrogen liquefaction, which combines the use of a nitrogen auto-refrigeration cooling cycle with one or more closed-loop refrigeration cycles using two or more refrigerant components. The closed-loop refrigeration cycle provide refrigeration in a temperature range having a lowest temperature between about -125°F . and about -250°F . A nitrogen expander cycle provides additional refrigeration, a portion of which is provided at temperatures below the lowest temperature of the closed-loop or recirculating refrigeration cycle or cycles. The lowest temperature of the nitrogen expander cycle refrigeration range is between about -220°F . and about -320°F . The combined use of the two different refrigerant systems allows each system to operate most efficiently in the optimum temperature range, thereby reducing the power consumption required for liquefaction.

Gaseous nitrogen at 80°F , 1 atm is compressed to 25 atm pressure. Adiabatic compressor is employed for this purpose with 50% efficiency which also results in increasing the temperature of N_2 stream to 1577°F . The stream is further cooled to -306°F with the help of a series of cooler and heat exchanger. Cooled N_2 is further expanded by reducing the pressure to 1 atm using an isenthalpic valve to obtain liquified N_2 .

URL: <https://dwsim.fossee.in/flowsheeting-project/dwsim-flowsheet-run/4>

2.2 Production of Methane from Carbon Monoxide and Hydrogen(using Recycle)

Author: Pravinkumar Bharat Dalve

Institution: Indian Institute of Technology Bombay

A synthesis gas containing CO , H_2 , and a small amount of CH_4 with a CO to H_2 ratio of 1:2.9 is upgraded to a higher methane content via the reaction

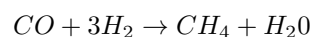

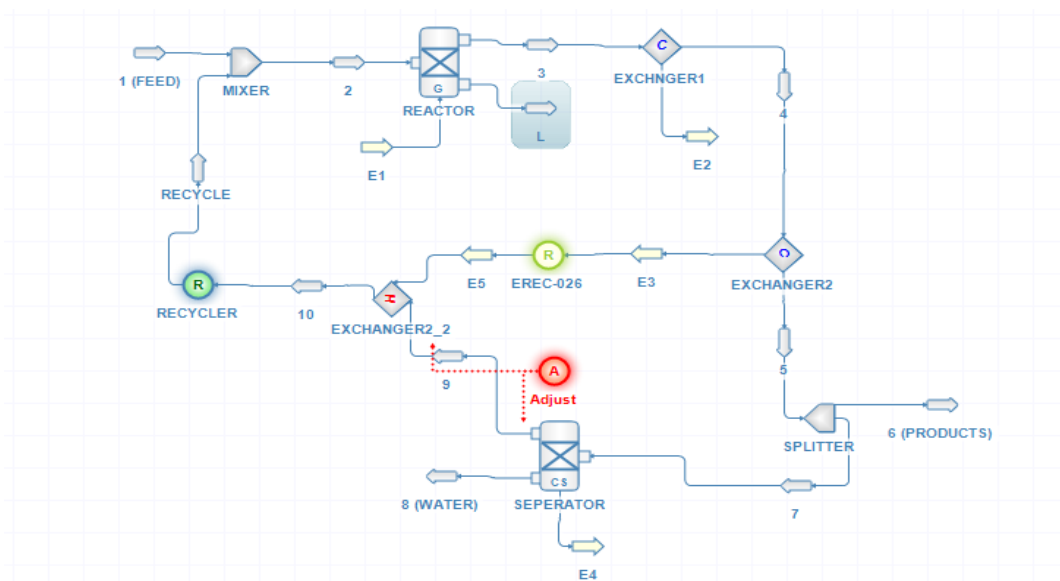

The reactor is operated adiabatically with a maximum outlet temperature of 1000°F to produce a product stream containing 50% CH_4 and 12% CO . The heat removal rate in the heat exchanger is adjusted to cool the reactor effluent stream to 500°F. The separator is operated so as to result in a recycle gas stream containing 1% H_2O and a pure liquid water stream, both at 100°F. The recycle gas stream is sent back to mix with feed and enters the reactor. Both the feed and the product streams are at 200°F. The entire system is operated at 100 psia. Separation in DWSIM has been achieved by using compound separator.

URL: <https://dwsim.fossee.in/flowsheeting-project/dwsim-flowsheet-run/5>

2.3 Production of Biodiesel

Author: Daniel Wagner

Institution: DWSIM Development Team

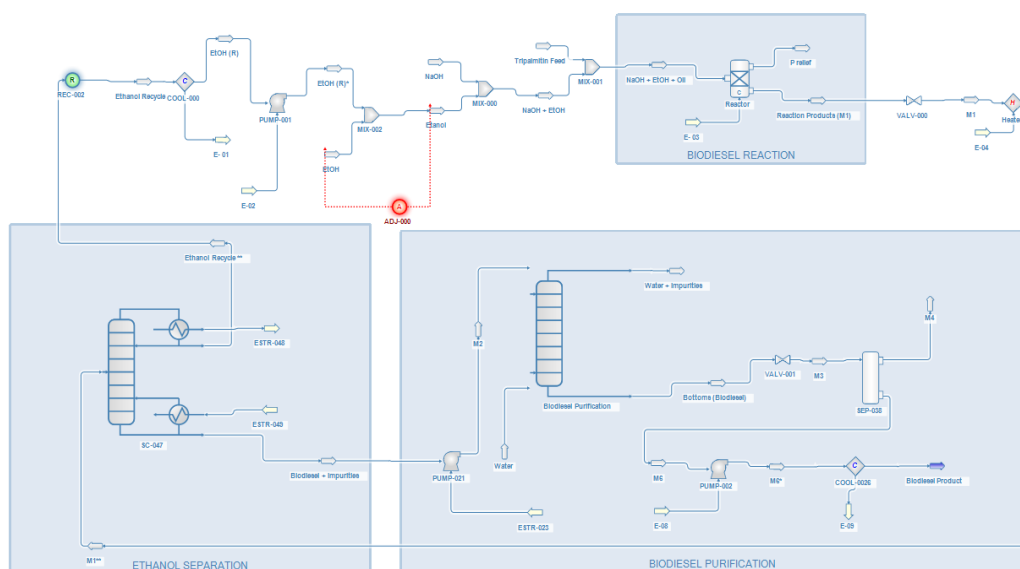

Biodiesel was introduced in South Africa before World War II to power heavy-duty vehicles. Recent environmental and domestic economic concerns have prompted a resurgence in the use of biodiesel throughout the world. Biodiesel can be produced through "transesterification"; a process that combines vegetable oils, animal fats, and/or microalgae oils with alcohol in the presence of a catalyst to form fatty esters. Products are separated into phases which provide easy removal of glycerol, a valuable industrial by-product, in the first phase. The remaining alcohol/ester mixture is then separated and the excess alcohol is recycled. Then the esters are sent to the clean-up or purification processes, which consist of water washing, vacuum drying, and filtration.

In this flowsheet, production of ethyl palmitate ($C_{18}H_{36}O_2$) from tripalmitin ($C_{51}H_{98}O_6$) has been demonstrated. Ethyl palmitate is a colourless solid with a wax-like odour. Chemically, ethyl palmitate is the ethyl ester of palmitic acid. Ethyl palmitate is used as a hair- and skin-conditioning agent. Tripalmitin feed along with ethanol is sent to a conversion reactor where reaction takes place between tripalmitin and ethanol to form ethyl palmitate and glycerol. The reactor is considered to have 95% conversion of tripalmitin. The product stream is first sent to a distillation column for ethanol separation. Ethanol recovered from top is recycled back to the mix with the feed stream. The bottom stream containing biodiesel along with other impurities are sent to an absorption column. Water is sent to the bottom of the column to absorb the other impurities from biodiesel while pure Ethyl Palmitate is obtained from the bottom.

URL: <https://dwsim.fossee.in/flowsheeting-project/dwsim-flowsheet-run/7>

2.4 Hydrogen Production through Methane Catalytic Steam Reforming

Author: Daniel Wagner

Institution: DWSIM Development Team

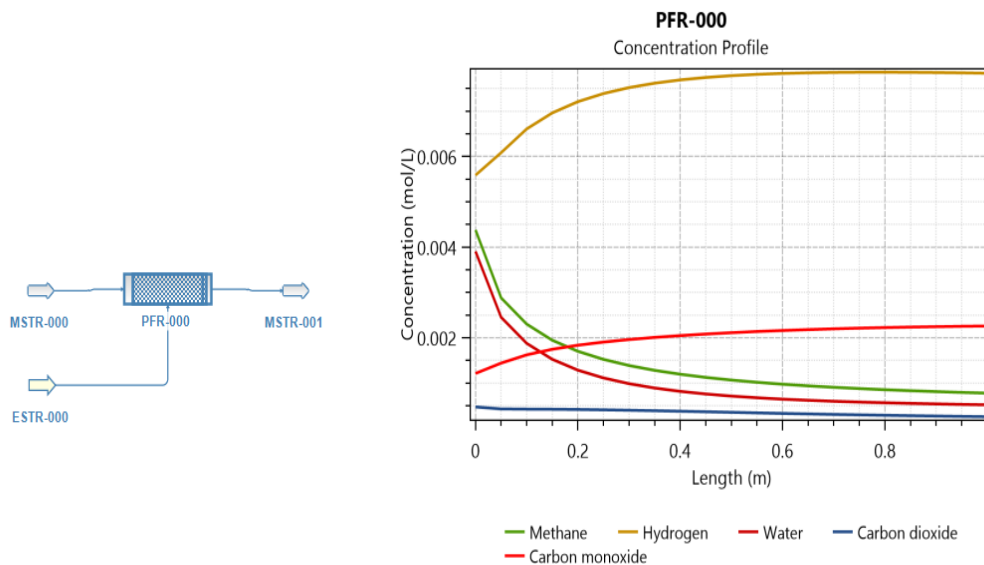

Natural gas has been proposed as a source of hydrogen for fuel cell vehicle applications because of the existing infrastructure. In a process known as steam reforming, natural gas and steam are reacted into mostly carbon monoxide and hydrogen with some carbon dioxide also produced. There can also be excess water in the reformat stream.

A feed consisting of 10000 mol/h CH_4 , 10000 mol/h H_2O , and 100 mol/h H_2 enters into a steam reforming reactor that operates at 1000 K and a 1 atm feed pressure. The reactions taking place in the

PFR are as follows:

The steam reforming reaction is given as:

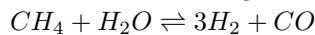

In the steam reformer, the water gas shift reaction also takes place as: $CO + H_2O \rightleftharpoons H_2 + CO_2$

Adding together the steam reforming and water gas shift reactions gives the overall reaction:

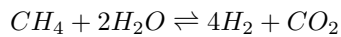

In the reactor, methane (CH_4) and water (H_2O) are fed as reactants and carbon dioxide (CO_2), carbon monoxide (CO), and hydrogen (H_2) are produced over a nickel catalyst on an alumina support. The weight of the catalyst is 386 g. The reaction takes place in isothermal mode with reactor volume of 1 m^3 . 75.62% conversion is obtained for methane.

URL: <https://dwsim.fossee.in/flowsheeting-project/dwsim-flowsheet-run/9>

2.5 Solid Carbon Combustion

Author: Daniel Wagner

Institution: DWSIM Development Team

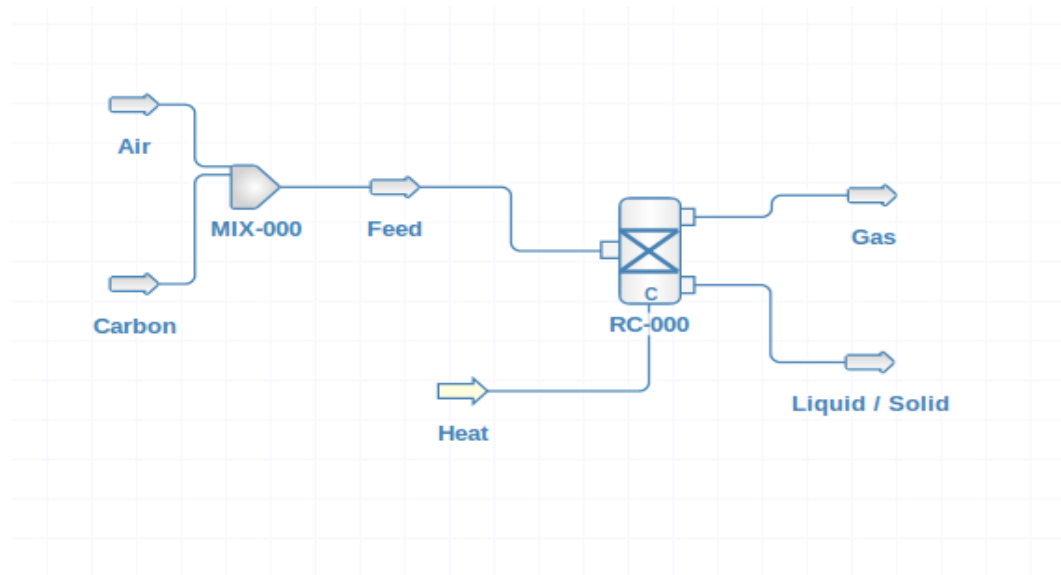

Combustion, or burning, is a high-temperature exothermic redox chemical reaction between a fuel (the reductant) and an oxidant, usually atmospheric oxygen, that produces oxidized, often gaseous products, in a mixture termed as smoke. Combustion in a fire produces a flame, and the heat produced can make combustion self-sustaining. Combustion is often a complicated sequence of elementary radical reactions. Solid fuels, such as wood and coal, first undergo endothermic pyrolysis to produce gaseous fuels whose combustion then supplies the heat required to produce more of them. Combustion is often hot enough that incandescent light in the form of either glowing or a flame is produced. In this process, solid carbon mixed with air at 298.15 K and 101325 Pa is sent to a conversion reactor. Reaction takes place between carbon and oxygen to form carbon dioxide where 100% conversion is considered for carbon.

URL: <https://dwsim.fossee.in/flowsheeting-project/dwsim-flowsheet-run/8>

2.6 Pressure Swing Azeotropic Distillation of Methanol-Acetone

Author: Priyam Nayak

Institution: Indian Institute of Technology Bombay

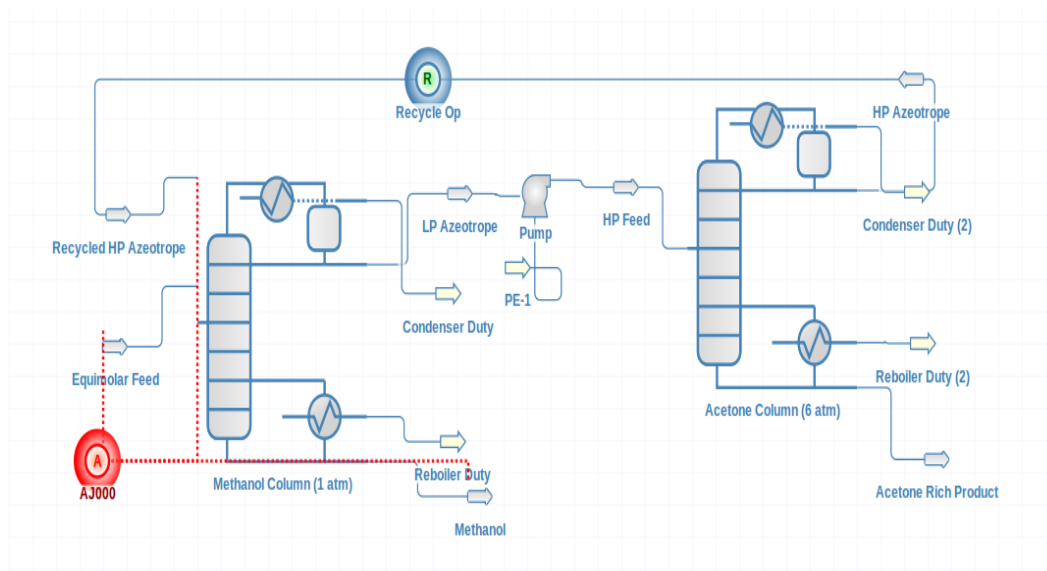

Pressure swing distillation is one of the most common methods for separating a binary homogeneous azeotrope. This method is preferred when the composition of the azeotrope changes with pressure.

In this process, equimolar amount of methanol - acetone mixture enters a low pressure column (LPC) at 300 K temperature and 1 bar pressure. The column consists of 52 stages including the condenser and reboiler. Feed enters at the 37th stage. The low pressure column operated at 1 bar. The column is operated at reflux ratio of 2.36. The distillate from the first column gives an azeotrope with 75% acetone (mol basis). The temperature of the top product is around 314 K. The bottoms from the column gives methanol with 99.5% purity. The top product from the LPC is pumped into a high pressure column (HPC) operating at 10 bar. The HPC consists of 62 stages with the pumped feed entering at 41st stage. The column is operated at reflux ratio of 3.11. The bottoms from the HPC gives 99.4% acetone. The distillate from the HPC comprising 60% methanol is recycled to the LPC at the 41st stage.

URL: <https://dwsim.fossee.in/flowsheeting-project/dwsim-flowsheet-run/10>

2.7 Natural Gas Processing Unit

Author: Daniel Wagner

Institution: DWSIM Development Team

One of the important processes in chemical engineering is the processing of natural gas. Moreover, improved production methods due to an increased supply and decreased cost of natural gas, have made the process much more significant. Though the composition of natural gas varies from source to source, it is mostly constituted by methane (70%) with a small amount of ethane, propane, n-butane, isobutane and heavier hydrocarbons. C_2 and heavier hydrocarbons are more valuable than methane and hence it is very important to recover them. C_2 and heavier hydrocarbons are called as 'Natural Gas Liquid'. Recovery is accomplished in a series of three distillation columns.

Recovery of hydrocarbons from the natural gas feed is achieved by using a series of distillation columns. First, industrial methane is separated in a high pressure cryogenic distillation column using expansion. The column is called demethanizer and is designed in a way to keep a low concentration of

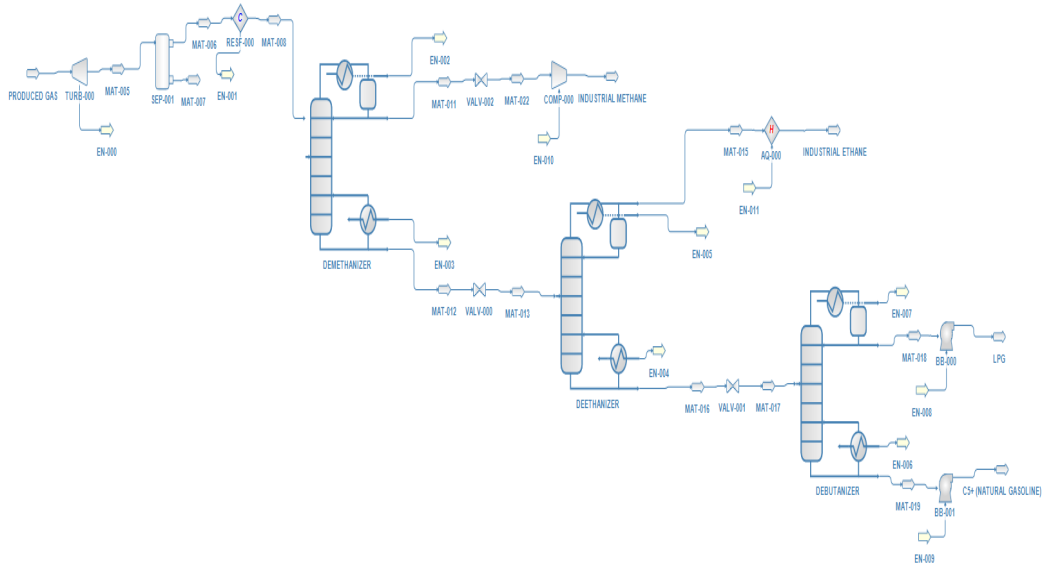

methane in its bottom product. The column is operated at 10 kgf/cm². Deethanizer is the second column, used in the process to recover industrial ethane. The column operates at 7 kgf/cm². Refrigeration is used in the condenser and the column is designed in such a way that the distillate only has a specified concentration of propane impurity. Debutanizer is the third column, used in the process to recover C₃ and C₄ which are in higher concentration as the distillate known as LPG. The column is operated at 5 kgf/cm². The bottom stream contains C₅ in high concentration along with traces of other hydrocarbons known as Natural Gasoline.

URL: <https://dwsim.fossee.in/flowsheeting-project/dwsim-flowsheet-run/11>

2.8 Simple LNG Exchanger Custom Unit Operation

Author: Daniel Wagner

Institution: DWSIM Development Team

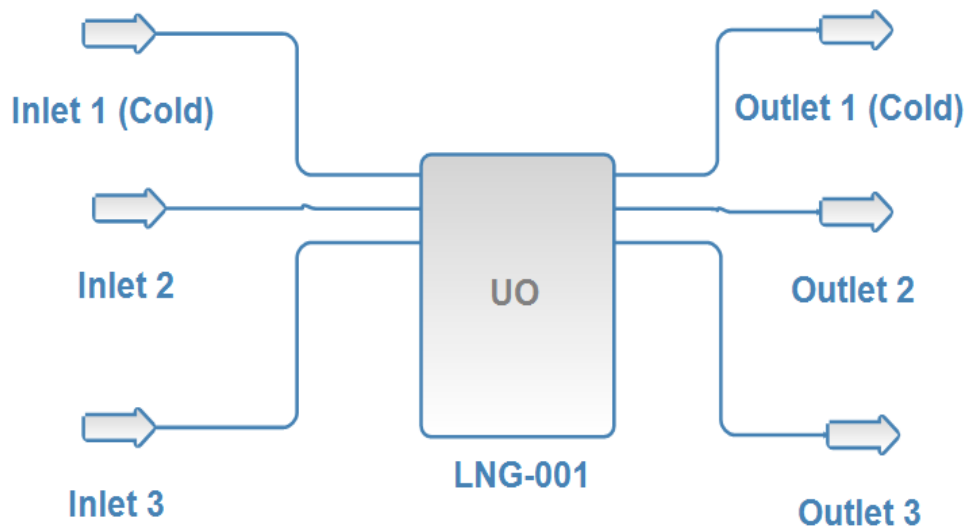

DWSIM is a free and open source steady state chemical process simulator. It follows the sequential modular approach. DWSIM has more than fifteen thermodynamic property packages built into it along with basic unit operations that can be used to build a process flowsheet. Furthermore, a user can also develop custom unit operations in DWSIM using Python scripts. This feature helps to develop unit operations that are otherwise not inherently available in DWSIM. This enhances the workability of the user to incorporate various features in DWSIM according to the needs of the user. This increases the versatility of DWSIM to be used in commercial process industries without the need for any proprietary tool.

This model of a simple LNG Plate-Fin Exchanger calculates the cold stream outlet temperature, provided that the user specifies all the other stream temperatures as input variables. Only the variables for existing streams need to be defined. The streams connected to the same port number on both inlet and outlet ports are considered to be the same, entering and leaving the exchanger without any mixing. The cold stream outlet temperature will be calculated only if the driving force (heat available for transfer) is lower than the heat required, indirectly specified by the user through the outlet temperatures. Python script has been used for the creation of custom module for calculation of cold stream outlet temperature.

URL: <https://dwsim.fossee.in/flowsheeting-project/dwsim-flowsheet-run/12>

2.9 Sour Water Stripping

Author: Daniel Wagner

Institution: DWSIM Development Team

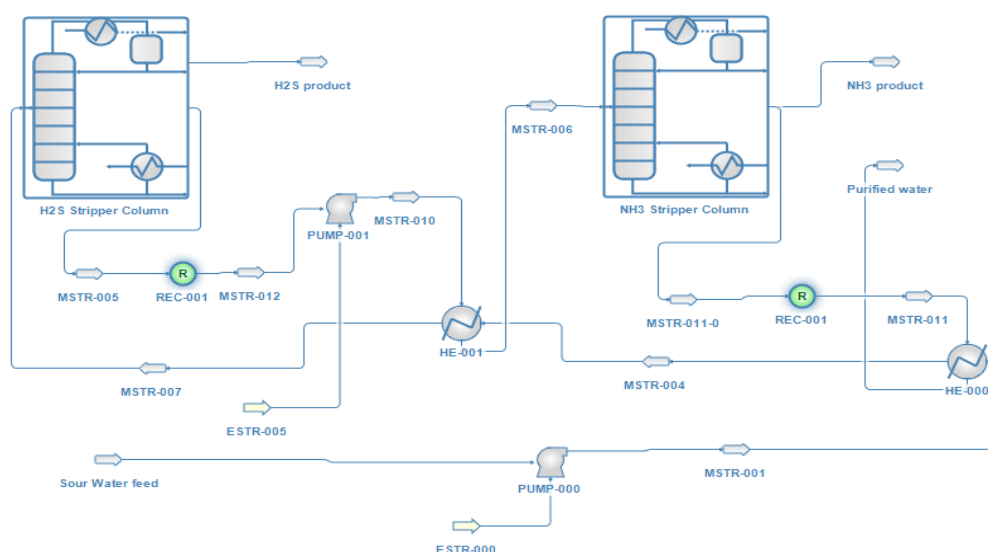

Sour Water is the wastewater that is produced from atmospheric and vacuum crude columns at refineries. Hydrogen sulfide (H_2S) and ammonia (NH_3) are typical components in sour water that need to be removed before the water can be reused elsewhere in the plant. Removal of these components is done by sending the sour water from the process to a stripping tower where heat, in the form of steam, is applied. The ammonia and hydrogen sulfide contained in the water is released by the heat and exits the top of the tower. The gases removed from sour water received from the refinery are known as sour Gas and are pumped off to the Sulfur Recovery Unit (SRU). This degassed sour water is pumped into a storage tank that serves to dampen the flow rate and facilitates removal of entrained oil and solids.

The first step in this process is known as hydrogen sulfide stripping. The degassed sour water is fed to the acid gas or H_2S stripper column, which is a steam-reboiled distillation column. The hydrogen sulfide, which is stripped overhead, is of high purity - an excellent feed for sulfur recovery units or sulfuric

acid plants. The column used for the purpose of H_2S stripping has 20 stages and is operated with reflux ratio of 2.

Next, the hydrogen sulfide stripper stream, containing all the ammonia in the feed water and some hydrogen sulfide, is fed directly to the NH_3 stripper column, which is a refluxed distillation column. In this column, essentially all ammonia and hydrogen sulfide are removed from the water. This column has 12 stages with feed entering at 2nd stage. After exchanging heat with the hydrogen sulfide stripper feed, the stripped water is cooled and sent off for either reuse or treating.

URL: <https://dwsim.fossee.in/flowsheeting-project/dwsim-flowsheet-run/13>

2.10 Removal of Isopentane in Gasoline Manufacturing Plant

Author: Priyam Nayak

Institution: Indian Institute of Technology Bombay

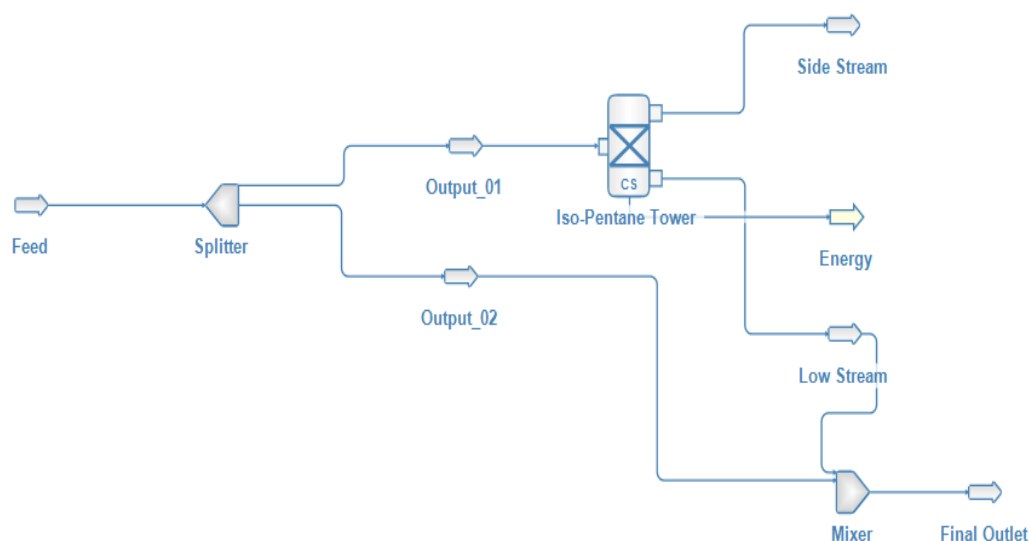

Bypass is an important type of process stream commonly encountered in process industries. It skips one or more stages of the process and goes directly to another downstream stage. A bypass stream can be used to control the composition of a final exit stream from a unit by mixing the bypass stream and the unit exit stream in suitable proportions to obtain the desired final composition.

In a feedstock preparation section of a plant manufacturing natural gasoline, it is important to remove isopentane from butane-free gasoline. In this process, butane-free gasoline consisting of N-pentane and isopentane which are obtained from the bottoms of the debutanizer in the ratio of 4:1 is used as feed. 44.5% of the butane-free gasoline directly proceeds to the next stage in the natural gasoline plant. Rest of the butane free gasoline is sent to isopentane tower where isopentane is completely removed as top product and N-pentane is obtained from the bottoms. The obtained pure N-pentane is directly sent to natural gasoline plant. Splitter unit of DWSIM is used to bypass a part of the feed stream and compound separator unit is employed for the isopentane tower.

URL: <https://dwsim.fossee.in/flowsheeting-project/dwsim-flowsheet-run/14>

2.11 Separation of Benzene from Air using Compression

Author: Rohan Adhikari S

Institution: National Institute of Technology Karnataka, Surathkal

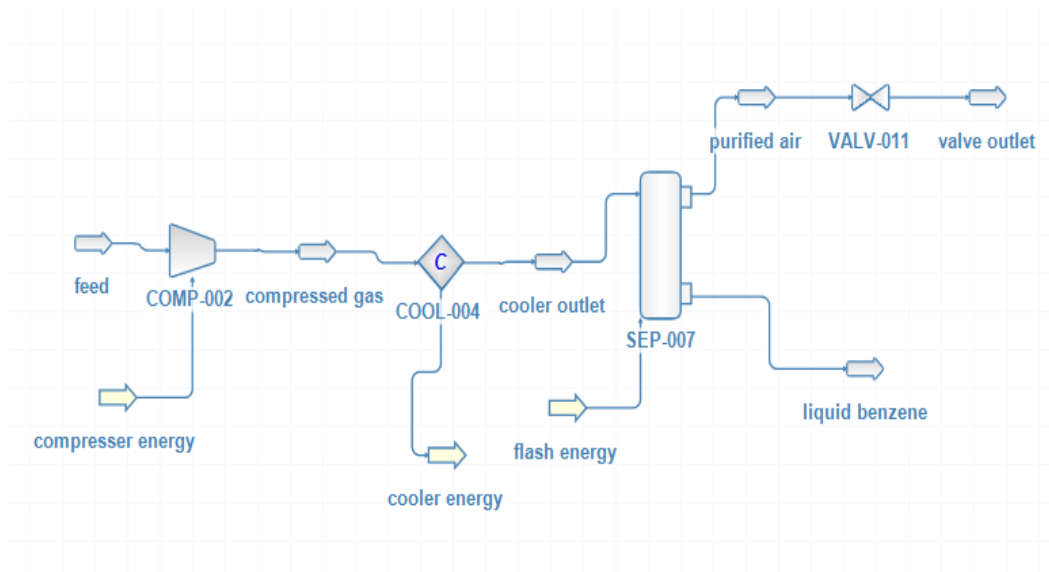

Emission of volatile organic compounds from processes is closely regulated. Both the Environmental Protection Agency (EPA) and the Occupational Safety and Health Administration (OSHA) have established regulations and standards regarding emissions and the frequency of exposure. This problem concerns the first step of the removal of benzene vapor from an exhaust stream, designed to recover 95% of the benzene from the air by compression. The exit pressure needs to be calculated using Raoult's Law.

In this example, the air-benzene mixture containing 0.982 mol fraction of air, at 26°C and 1 atm pressure is sent at the rate of 1kg/s(feed) to an adiabatic compressor. The increase in pressure is 142 atm, which is calculated using Raoult's Law. Next, the compressed mixture is sent to a cooler to bring its temperature down to 26°C . This brings about a condensation of benzene vapors, air is essentially non-condensable. The adiabatic compressor and cooler, together, act as an isothermal compressor. Next, the Vapor-Liquid mixture is sent to a flash separator to separate liquid benzene from the vapor. Purified air is sent to a valve which reduces its pressure from 143 atm to 1 atm. This air can be further purified or let out depending on the safety standards.

URL: <https://dwsim.fossee.in/flowsheeting-project/dwsim-flowsheet-run/15>

2.12 Distillation Of Aqueous Acetone

Author: Kg Srinidhi

Institution: National Institute of Technology Karnataka, Surathkal

Acetone is used as a solvent in various processes. It is economically viable to recycle used acetone, rather than using fresh acetone in a given industry. Hence, simple distillation can be carried out, especially if it's a mixture of acetone and higher boiling components (like water).

The feed enters at 10000kg/h with a mass fraction of 0.25 at 26.7°C , into a preheated heat exchanger, where it is heated for up to 38°C by the bottoms of the distillation column. The preheated feed then enters the 3rd stage of the 10 stage distillation column, which operates with a 1 atm condenser and a boiler pressure of a reflux ratio of 9.16.

The distillate obtained contains 0.95 mol fraction of acetone at 2386.13kg/h, and the bottoms is obtained at 7614kg/h at 96°C temperature, which is recycled to a heat exchanger and used to preheat the feed.

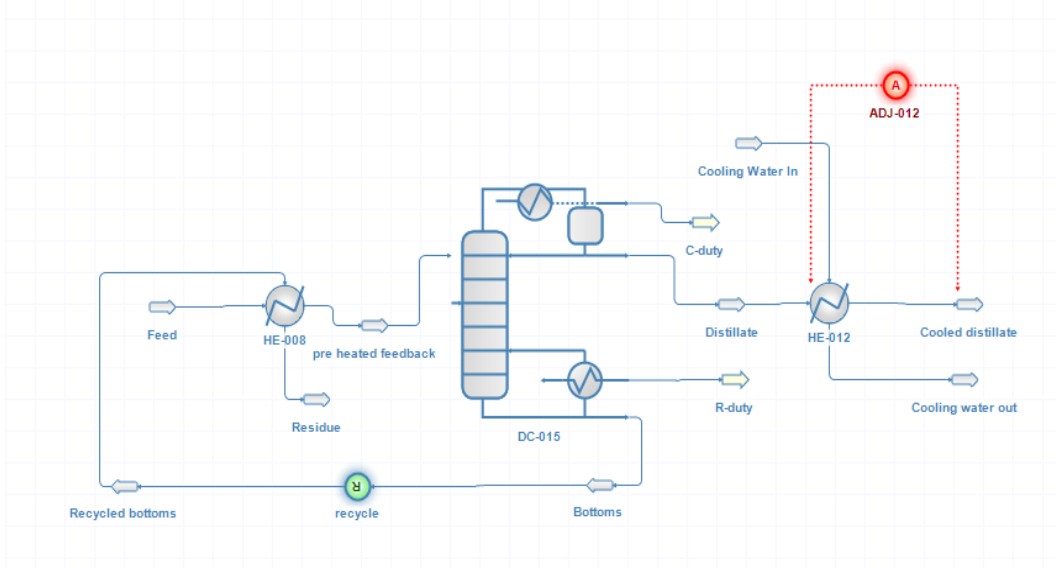

Also, the distillate obtained is cooled in a heat exchanger with cooling water at 26.7°C , where the heat exchanger is designed to provide purified acetone at 38°C temperature as the final product. The Roul't's Law property package is used in the flowsheet.

URL: <https://dwsim.fossee.in/flowsheeting-project/dwsim-flowsheet-run/16>

2.13 Open Cycle Steam Turbine

Author: Rohan Adhikari S

Institution: National Institute of Technology Karnataka, Surathkhal

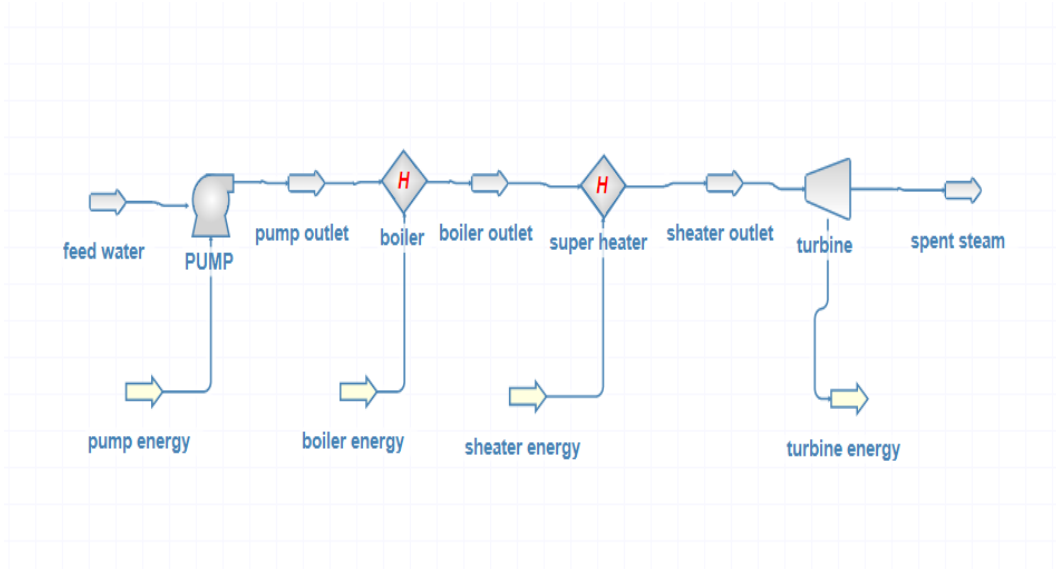

A steam turbine is a device that extracts thermal energy from pressurized steam and uses it to perform mechanical work on a rotating output shaft. Its modern manifestation was invented by Sir Charles Parsons in 1884. As the turbine generates rotary motion, it is particularly suited to be used

to drive an electrical generator. The steam turbine is a type of a heat engine that derives much of its improvement in thermodynamic efficiency from the use of multiple stages in the expansion of the steam, which results in a closer approach to the ideal reversible expansion process.

Water at $65^{\circ}F$, 14.7 psi and a mass flow rate of 2000 pound mass /hour is sent into a pump to increase its pressure to 250 psi. This water at high pressure is heated to its boiling point using a boiler ($401^{\circ}F$). This vapor is now super-heated in a heater to $550^{\circ}F$ to ensure that condensation of the steam doesn't occur in the adiabatic expander. This superheated vapor is sent to a turbine in which the steam expands adiabatically and rotates the shaft, which is connected to an electromagnet to produce electricity. The spent steam is recycled to be reused, at times.

URL: <https://dwsim.fossee.in/flowsheeting-project/dwsim-flowsheet-run/20>

2.14 Closed Loop Steam Turbine

Author: Kg Srinidhi

Institution: National Institute of Technology Karnataka, Surathkal

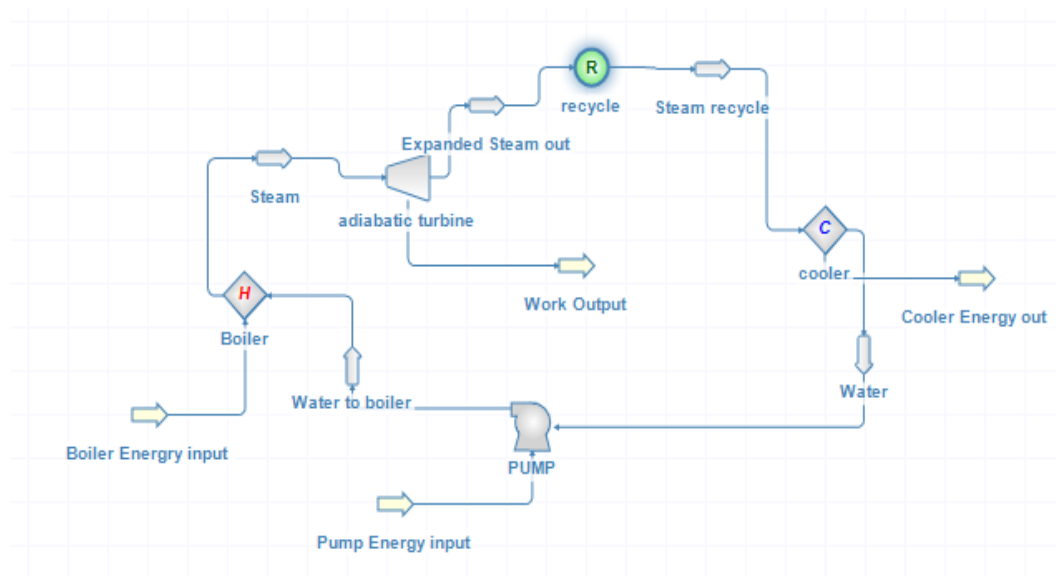

In thermal power plants closed loop steam driven turbines are used extensively to convert heat energy to electrical energy. This is simulation of basic steam power plant.

Steam at 8 kg/s enters the adiabatic turbine, at $500^{\circ}C$ and 10000 kPa pressure, and runs the turbine. The turbine operates at 75% efficiency and generates about 19858 kW of power. The expanded steam exits the turbine at $60^{\circ}C$ and 20kPa pressure. This steam is further cooled down to $40^{\circ}C$, where 6684 kW of energy is extracted. The steam is then condensed to water and is recycled again. This water output from the cooler is pumped into a boiler, with an increase in pressure back to its feed pressure of 10000 kPa. The pump used has 75% efficiency. Now the water which enters the boiler at elevated pressure is again heated up to $500^{\circ}C$ to get back the initial steam feed conditions. The energy input for the heater is 26441 kW which is used up to boil it to the feed conditions. Now this steam output from the boiler is fed to the adiabatic turbine to complete the closed cycle steam turbine system.

URL: <https://dwsim.fossee.in/flowsheeting-project/dwsim-flowsheet-run/19>

2.15 Methanol Water Distillation With Preheating

Author: Rohan Adhikari S

Institution: National Institute of Technology Karnataka, Surathkal

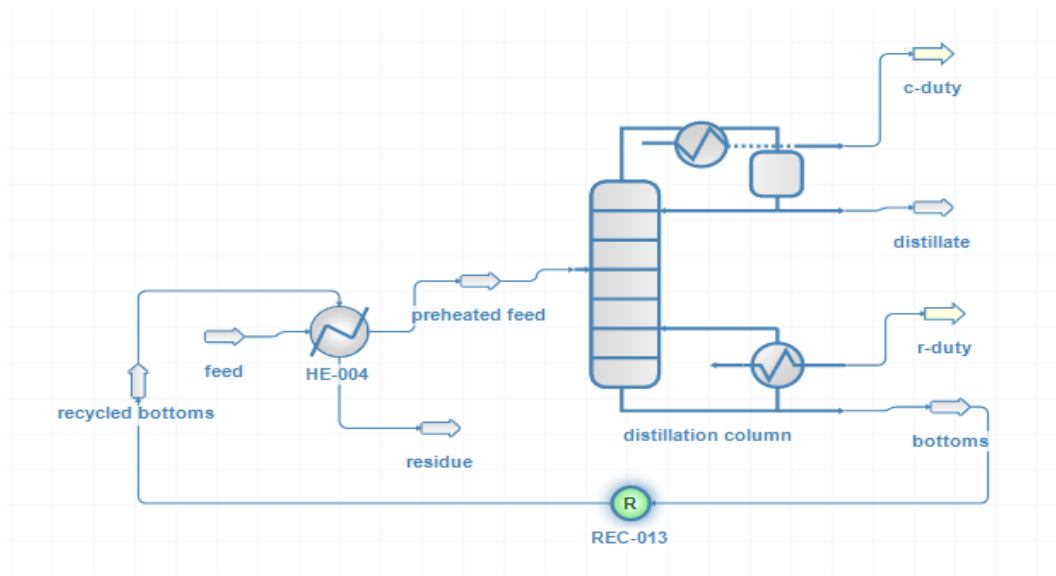

Preheating of the feed in distillation columns is usually carried out for the following reasons:

- To save energy: The feed pre-heater normally uses the residue/bottoms from the tower or uses waste heat or low pressure steam with little value. This saves more valuable re-boiler steam.
- Supplements re-boiler capacity: If the tower is not limited by the condenser, but limited by the capacity of the re-boiler, then more feed pre-heat will permit higher reflux rates and hence better fractionation efficiency.
- Stops flooding in bottom section trays: If the tower is limited by flooding or entrainments in the bottom stripping trays, then more feed preheat (which reduces the re-boiler duty) will improve fractionation.

The feed is sent to a heat exchanger where it is heated by the recycled bottoms from the distillation column. Preheated feed is now sent into the distillation column and the reflux ratio is changed, until the required output product composition is obtained.

URL: <https://dwsim.fossee.in/flowsheeting-project/dwsim-flowsheet-run/21>

2.16 Vapor Compression Refrigeration Cycle

Author: Rohan Adhikari S

Institution: National Institute of Technology Karnataka, Surathkal

The Vapor Compression Refrigeration system is one in which the refrigerant undergoes phase changes. It is one of the many refrigeration cycles and is a widely used method for air conditioning and for automobiles. It is used in domestic and commercial refrigerators, large-scale warehouses for chilled or frozen storage of foods and meats, refrigerated trucks and railroad cars, and in a host of other commercial and industrial services. Oil refineries, petrochemical and chemical processing plants and natural gas processing plants are amongst the many industrial plants that often utilize large vapor-compression

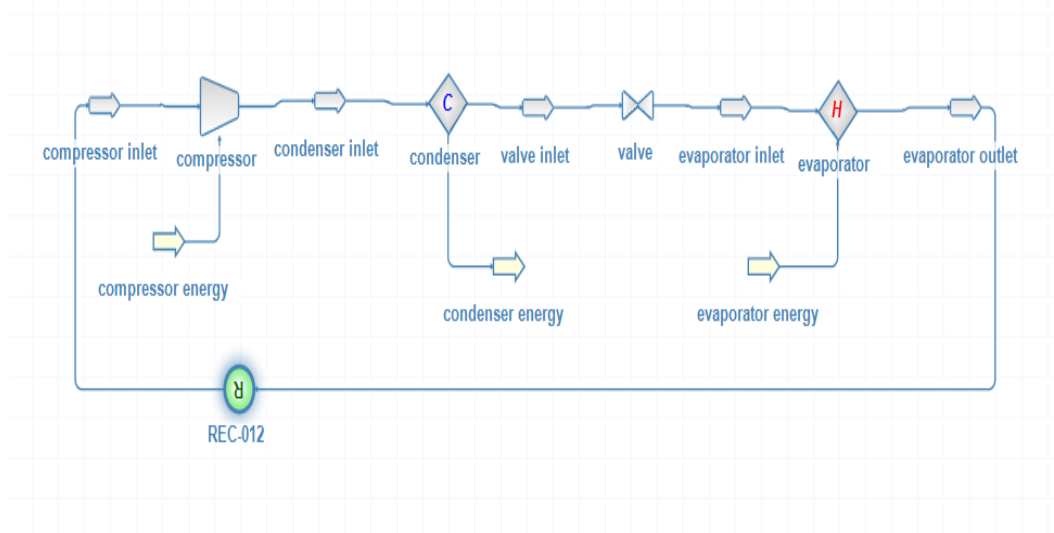

refrigeration systems. In very basic terms, refrigeration systems are used to remove heat from one area and transfer it to another area.

The vapor compression system simulated here uses propane as the liquid refrigerant medium because of its favorable properties. The circulating refrigerant enters the adiabatic compressor in the thermodynamic state known as ‘saturated vapour’. The compressor increases its pressure and temperature, and propane leaves the compressor in the super-heated vapor state. This super-heated vapor now enters the condenser, which converts it into a saturated liquid at the same pressure. Now this saturated liquid is at a high pressure and hence is throttled with the help of a valve. A vapor-liquid mixture at atmospheric pressure is sent to an evaporator which converts the mixture to saturated vapors, and the outlet stream from the evaporator is recycled. This is then sent as an input to the adiabatic compressor.

URL: <https://dwsim.fossee.in/flowsheeting-project/dwsim-flowsheet-run/23>

2.17 Carnot Engine

Author: Rohan Adhikari S

Institution: National Institute of Technology Karnataka, Surathkal

A Carnot engine is an engine which operates on the reversible Carnot cycle. The basic model for this was developed by Nicolas Sadi Carnot in 1824.

Gas at a high temperature (in this case Helium at 600 K) absorbs heat from the heat reservoir reversibly, and hence undergoes an isothermic expansion. This is modeled with the help of a valve (also called the isothermal expander). The outlet from this is then sent to an adiabatic expander, where the gas undergoes an expansion. Therefore, there is a decrease in its temperature till it reaches the temperature of the cold reservoir.

The gas now rejects heat isothermally into the cold reservoir (reversibly) and this can be modeled as an isothermal compression using a valve (also called the isothermal compressor). The gas is sent to an adiabatic compressor where its temperature and pressure are increased until its properties are identical with that of the inlet stream. This is accomplished using the recycle block.

URL: <https://dwsim.fossee.in/flowsheeting-project/dwsim-flowsheet-run/24>

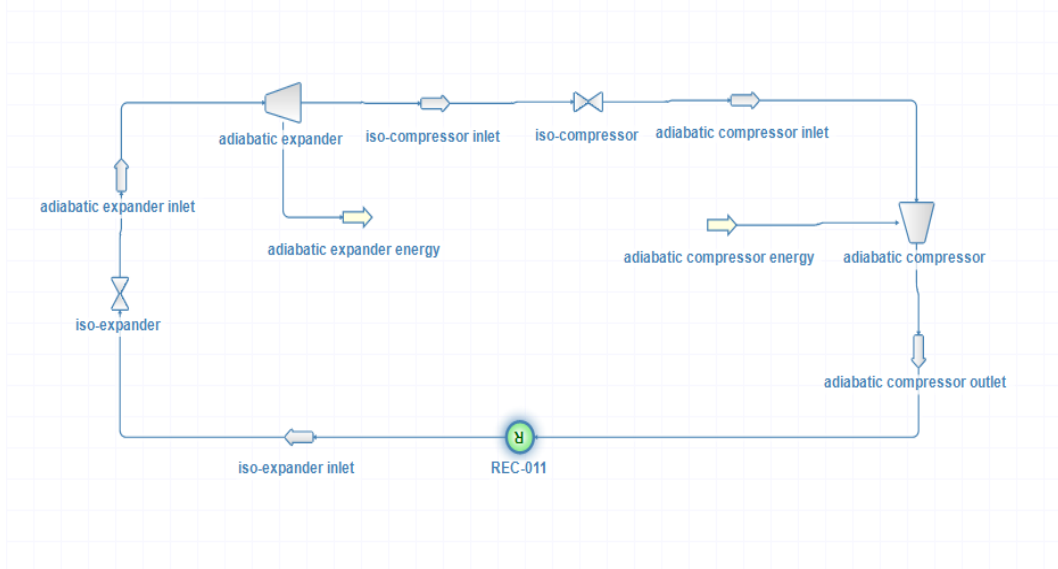

2.18 A Simple De-Humidification System

Author: K G Srinidhi

Institution: National Institute of Technology Karnataka, Surathkal

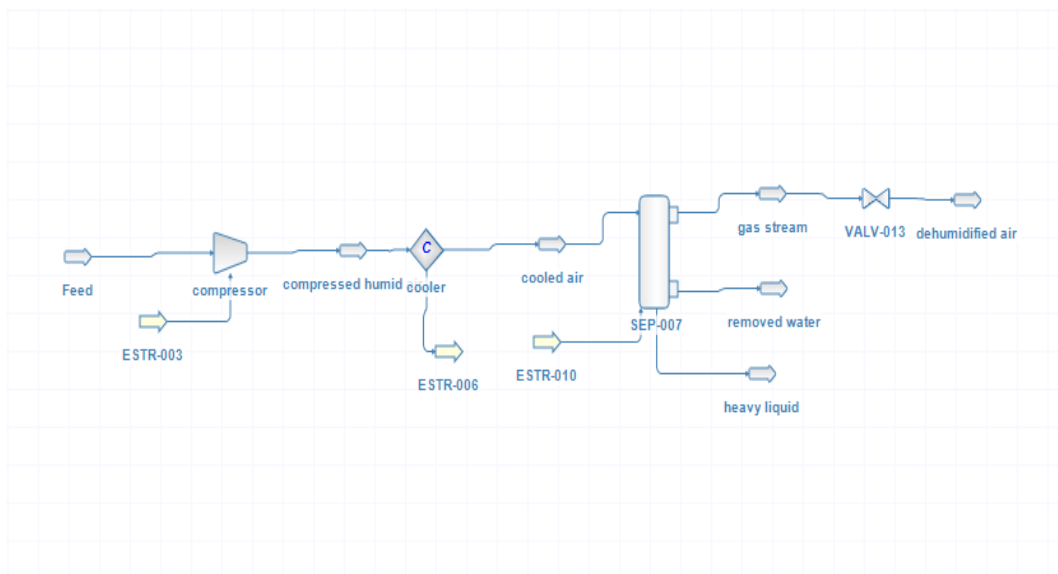

The process in which the moisture/water vapours/humidity is removed from the air, keeping its dry bulb (DB) temperature constant, is called the ‘dehumidification process’. Relative humidity in dwellings should preferably range from 30% to 50%. Dehumidifiers reduce the levels of humidity, making a room less hospitable to allergens (such as dust mites, mold, and mildew).

Dehumidifiers are used in industrial climatic chambers to reduce the relative humidity and the dew point in many industrial applications (from waste and fresh water treatment plants to indoor grow rooms), where the control of moisture is essential.

The feed enters at a flow rate of 3600 kg/h and a relative humidity of 68% at 100 kPa pressure and a temperature of 20°C . This feed air enters the compressor which increases the pressure to 275 kPa. The compressed air is cooled to a temperature of 20°C using a cooler. This cooled air is passed on to a gas liquid separator, where the condensed water can be separated. The gas-liquid separator separates

the condensed liquid, which is at a flow rate of 16.85 kg/h. The top product of the gas-liquid separator is depressurised to 100 kPa using a valve. The product obtained from the valve is the dehumidified air, which has a relative humidity of 36.3%.

URL: <https://dwsim.fossee.in/flowsheeting-project/dwsim-flowsheet-run/22>

2.19 A Heat Pump System using CO_2 as Refrigerant(R744)

Author: K G Srinidhi

Institution: National Institute of Technology Karnataka, Surathkal

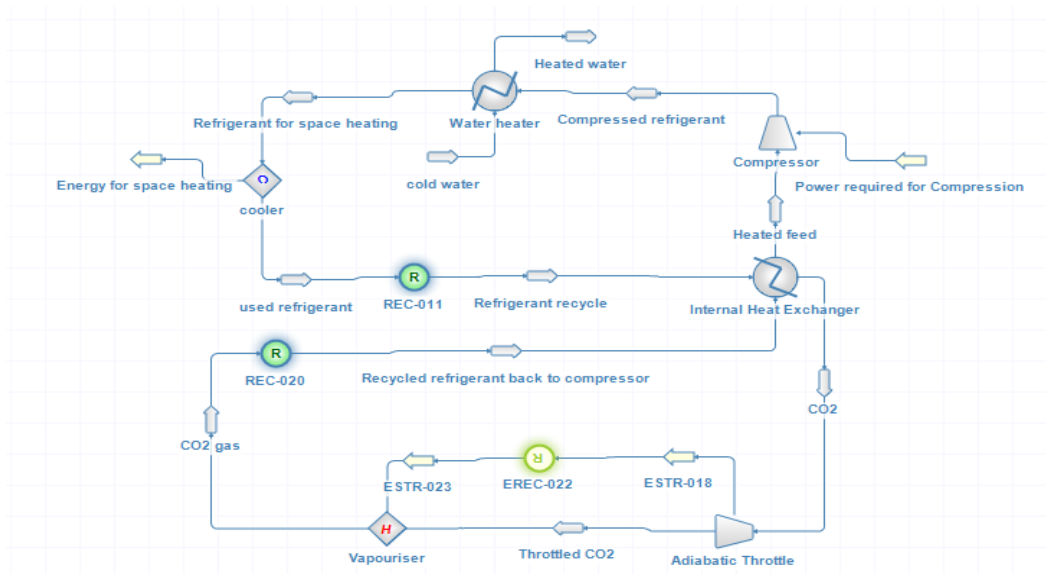

The return to carbon dioxide as a refrigerant has been the latest hot topic. The two seemingly major problems of high pressure and high compressor temperature are found, in fact, to be advantageous. The very high cycle pressure results in a high fluid density throughout the cycle, allowing miniaturization of the systems, for the same heat pumping power requirements.

The CO_2 refrigerant enters an adiabatic compressor at $30^\circ C$ at 3.5 MPa and 50 kmol/h. It is compressed to 13 MPa, which results in a temperature of $162^\circ C$. This compressed refrigerant is used for heating water at 1000 kg/h, from $25^\circ C$ to $70^\circ C$.

The refrigerant at $70^\circ C$ is further used for space heating and hence, is cooled to $45^\circ C$. This refrigerant is further recycled to preheat the initial refrigerant that enters the compressor in a heat exchanger. The recycled refrigerant is then throttled adiabatically to 3.5 MPa and vaporized (through the process of heating by a heater).

The energy output from the throttling can be recycled to the heater to vaporize the refrigerant. The regenerated and recycled refrigerant is obtained, which is preheated and sent to the compressor (as explained).

URL: <https://dwsim.fossee.in/flowsheeting-project/dwsim-flowsheet-run/25>

2.20 Benzene Toluene Fractionation Unit

Author: K G Srinidhi

Institution: National Institute of Technology Karnataka, Surathkal

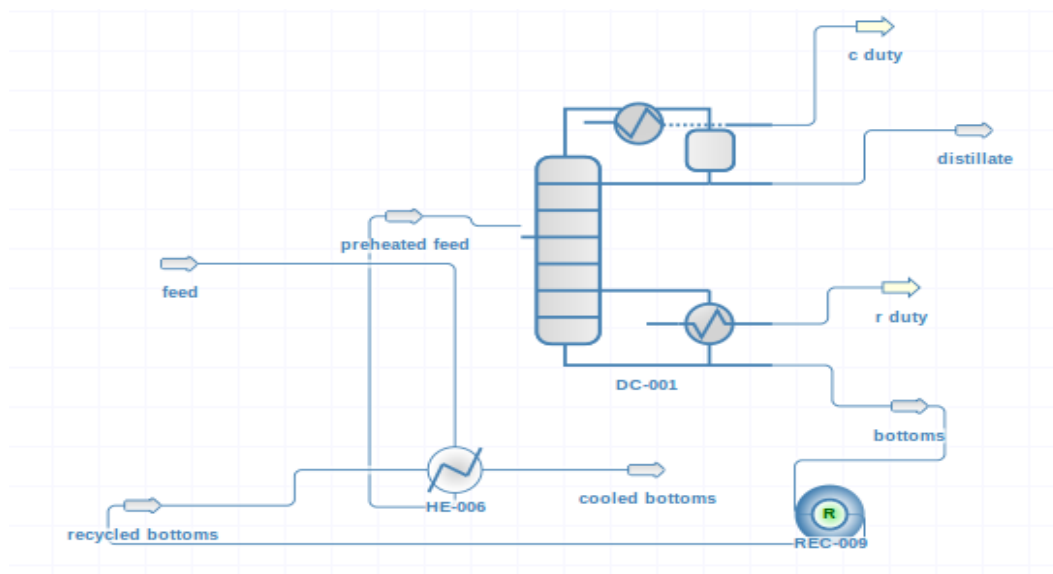

Benzene Toluene Fractionation is a process that produces pure benzene via Benzene Distillation, which has been carried out since the past decade. The Benzene/Toluene fractionator is part of an aromatics extraction unit. The aromatics are extracted from an aromatics rich stream using liquid/liquid extraction. The benzene is separated from the aromatic extract in a distillation column.

The equimolar mixture of benzene and toluene feed enters at 100 kmol/h at 25°C into a preheated heat exchanger, where it is heated up to 40.32°C by the bottoms of the distillation column. The preheated feed then enters the 11th stage of the 24 staged distillation column, which operates with a 1 atm condenser, and the boiler pressure at a reflux ratio of 10. The distillate obtained has 0.91 mol fraction of benzene at 55 kmol/h and the bottoms is obtained at 45 kmol/h at a temperature of 110.4°C, which is recycled to a heat exchanger and used to preheat the feed. The distillate thus, is purified benzene, which is obtained at 82°C and is the final product. The cooled bottoms at 83°C is highly pure toluene with a mol fraction of 0.999, which is also of immense importance to the industry. The Rault's Law property package is used in the flowsheet.

URL: <https://dwsim.fossee.in/flowsheeting-project/dwsim-flowsheet-run/26>

2.21 Azeotropic Distillation of Butanol and Water

Author: Koona Prabhu Teja

Institution: National Institute of Technology Karnataka, Surathkal

The recent surge in crude-oil prices and issues of energy independence and carbon dioxide emissions have generated a new interest in bio fuels. Traditional bio based processes produce n-butanol amongst the other isomers. Butanol forms an azeotrope with water at 0.5 atm, 780°C, with compositions of around 77.85% water, 22.15% n-butanol. Breaking the azeotrope, the vapor from two absorbers coupled with a decanter forms the basis for the separation.

The feed at 780°C is admitted to a re-boiled absorber at an intermediate stage of a 10 stage column. The aqueous liquid from the decanter (Recycle to the 1st column) at 700°C is fed to the top stage. A small fraction of vapor in the feed at a higher temperature, and the liquid, undergo a flash at each stage. The feed composition of 0.98 water and 0.02 butanol on the right extreme of the azeotropic composition ensures that the fraction of water in the vapor is reduced, leaving the over-head product richer in butanol as compared to that in the feed.

The organic phase from the decanter (also a recycle), is fed to a 10 stage re-boiled absorber. The

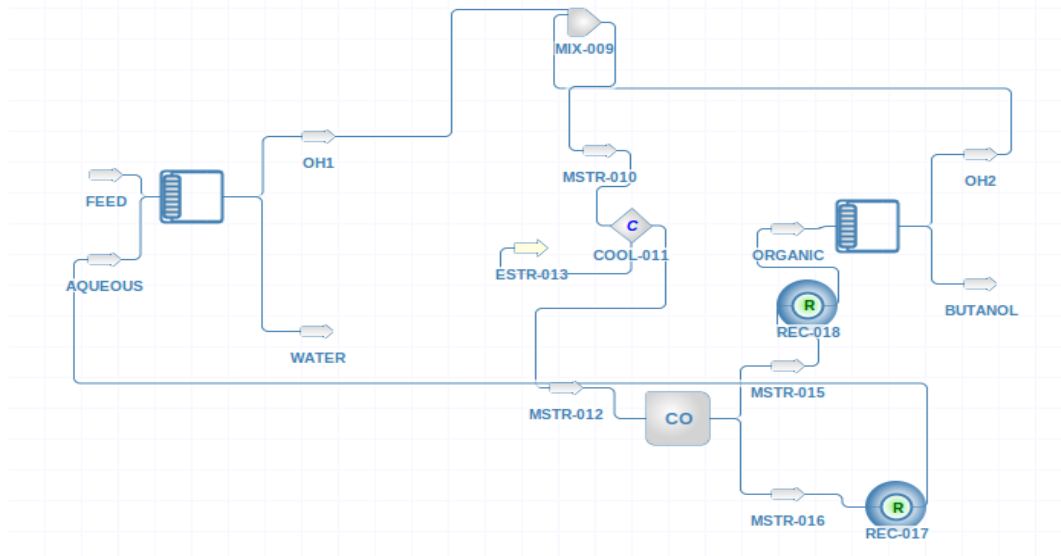

composition of the over-head vapor is close to the azeotrope. The vapors from the 2 columns are fed to a mixer, which in turn is cooled to 700°C , to bring it to a liquid-liquid phase.

Now, the liquid is fed to a decanter (with appropriate models defined for Liquid-Liquid Separation) where the aqueous and organic phases are separated, which in turn are used as reflux for the respective columns.

URL: <https://dwsim.fossee.in/flowsheeting-project/dwsim-flowsheet-run/31>

2.22 Separation of Refinery Light Ends

Author: K Prabhu Teja

Institution: National Institute of Technology Karnataka, Surathkal

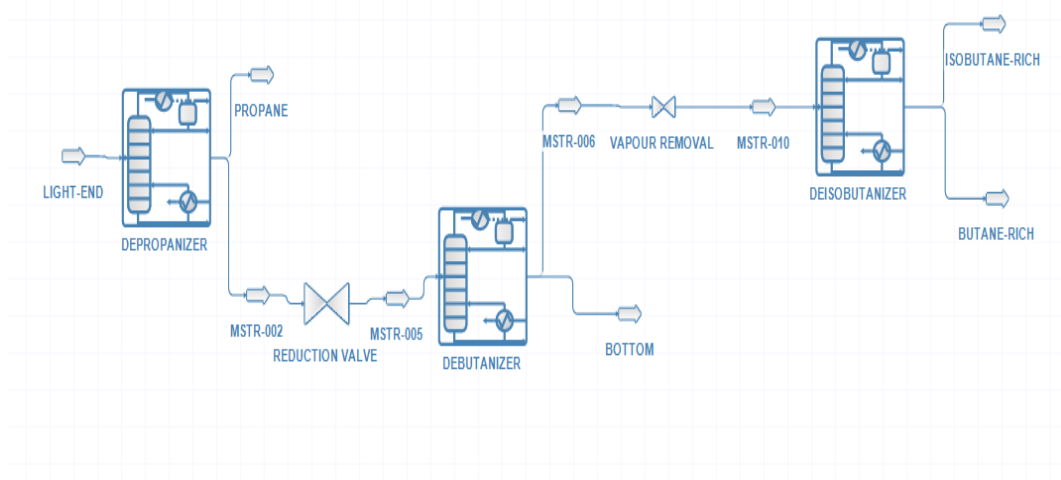

A large amount of carbon dioxide in natural gas from the well dictates the use of an extractive distillation system to separate ethane from the carbon dioxide, due to an azeotrope. The bottoms from

the ethane recovery column is called ‘natural gas liquid’ (NGL) and is fed to three distillation columns operating in series. The feed is a mixture of ethane (C_2), propane (C_3), iso-butane (iC_4), n-butane (nC_4), iso-pentane (iC_5), and n-pentane (nC_5). Propane, butane and iso-butane are removed successively in high pressure 3 stage distillation columns.

The first column is a de-propanizer. The separation of propane from the butane isomer mixture is a bit difficult. The column has 50 stages with a condenser pressure at 17 atm. The top and bottom pressures are 17.1 atm and 17.5 atm respectively. The high pressure in the condenser allows the usage of cooling water for temperature reduction. The feed enters the 18th stage at 17.4 atm. Design specifications for this column are 0.01% iso-butane, all ethane in distillate; 0.1 mol% propane in bottoms. The second column is a de-butanizer. Its function is to take the iC_4 and nC_4 components overhead for subsequent separation in the downstream column. The separation in the debutanizer is between the nC_4 and the iC_5 , which is fairly easy with a relative volatility of 2.2 at 322 K. A column with 31 stages is used, operating at 7.1 atm, with the feed reduced to a pressure of 7.3 atm at stage 16. The design specifications are 0.2 mol % iC_5 in the distillate, and 0.2 mol % nC_4 in the bottoms. The third column is a de-isobutanizer. The separation of the iC_4 and nC_4 is relatively difficult, so a 80 stage column is used. It operates at 6.6 atm, with the feed admitted to stage 39. The design specifications are 2 mol % nC_4 in the distillate, and 2 mol % iC_4 in the bottoms.

URL: <https://dwsim.fossee.in/flowsheeting-project/dwsim-flowsheet-run/32>

2.23 Extractive distillation of Methylal from Methanol using DMF

Author: Koona Prabhu Teja

Institution: National Institute of Technology Karnataka, Surathkal

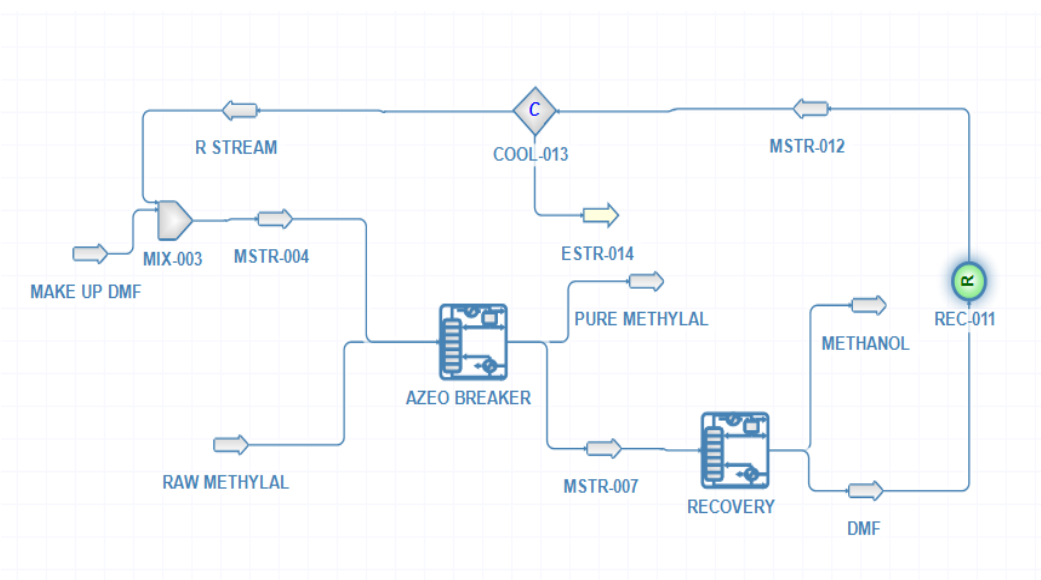

Methylal, also called dimethoxymethane, is an important intermediate that is widely used in many fields for its exceptional dissolving ability, extremely low viscosity, amphiphilic characteristics, low surface tension and particularly high evaporation rate. Unfortunately, methylal and methanol form a minimum-boiling azeotrope at atmospheric pressure, with 94.06 wt % of methylal. Thus, a methylal-methanol mixture cannot be completely separated through a simple distillation process. Extractive distillation can be an alternative. It involves adding a third substance (entrainer/solvent) that can alter the molecular properties of the two compounds of interest. Since it has different affinities to the key components, addition of the entrainer causes an increase in the relative volatility of the light and heavy key components.

The mixture "Methylal/Methanol/Water" is fed to the 42nd stage of the 52 stage extractive distillation column with the solvent DMF (Di-Methyl Formamide) fed to the 4th stage. The presence of the entrainer alters the relative volatility between the two, causing pure Methylal to move towards the top, and the mixture towards the bottom of the column. The mixture is fed into the 9th stage of a 22 stage recovery column to produce almost pure Methanol at the top, and almost pure solvent at the bottom. It is recycled back to the extractive distillation column and merged with one additional pure make-up stream to account for the solvent losses.

URL: <https://dwsim.fossee.in/flowsheeting-project/dwsim-flowsheet-run/33>

2.24 BTX Separation Chain and Energy Optimization

Author: Koona Prabhu Teja

Institution: National Institute of Technology Karnataka, Surathkal

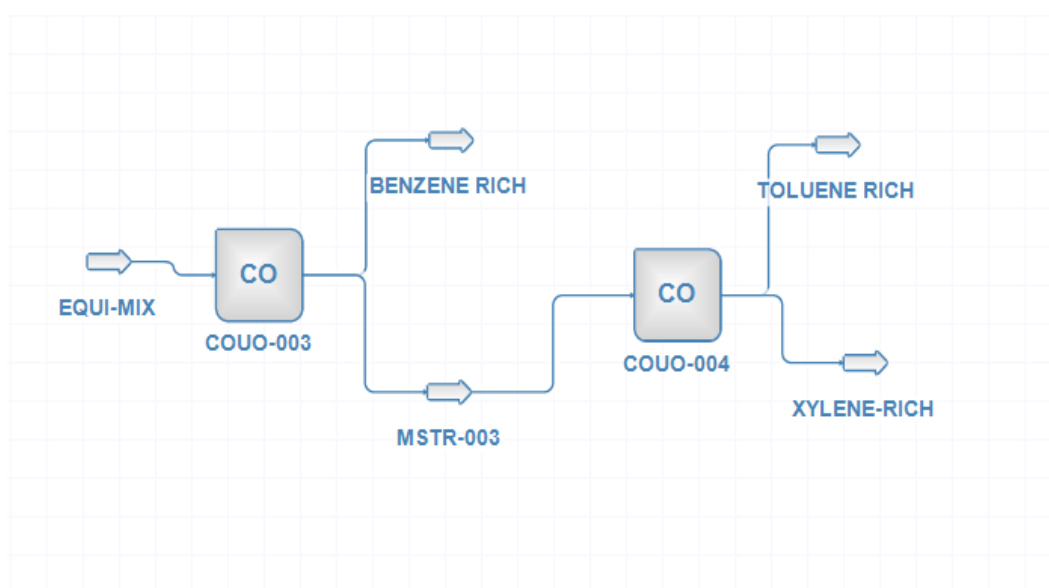

Benzene-Toluene-Xylene (BTX) are the major feedstock for a large number of intermediates which are used in the production of synthetic fibres. Styrene, linear alkyl benzene and cumene are major consumers of benzene. Toluene is majorly used as a solvent and as raw material in the manufacture of benzoic acid, chloro derivatives, nitro toluenes and benzaldehyde.

Amongst xylenes, about 80% of the production is constituted by that of para xylene, which is used in the manufacture of terephthalic acid. 'Catalytic reforming' is a refining process that uses selected operating conditions and selected catalysts to convert high value aromatic hydro carbon into BTX.

The conventional procedure for a simple separation can begin by introducing feed to a flash drum where light component(s) are vaporised and discharged from the top, and the liquid exits from the bottom. The bottom product will then be preheated either with warm products of the tower using several heat exchangers, or just by using a furnace (heater). The top product of the flash drum will meet the preheated liquid again, upon entrance to the tower where they are inserted as one single stream. An equi-molar mixture of BTX is sent to a 20 stage distillation column that operates at 1 atm pressure. The overhead is pure benzene (60°C-90°C), with the bottom containing a mixture of Toluene (90°C -110°C) and Xylenes (110°C -140°C), which are further distilled in a 30 stage column to yield pure products respectively. The emphasis is on the optimisation of feed tray and vapor fraction in the feed, which reduces reboiler load and a portion of energy that might be recovered through a condenser.

URL: <https://dwsim.fossee.in/flowsheeting-project/dwsim-flowsheet-run/34>

2.25 Esterification of Acetic Acid with Methanol to Methyl Acetate

Author: Priyam Nayak

Institution: Indian Institute of Technology Bombay

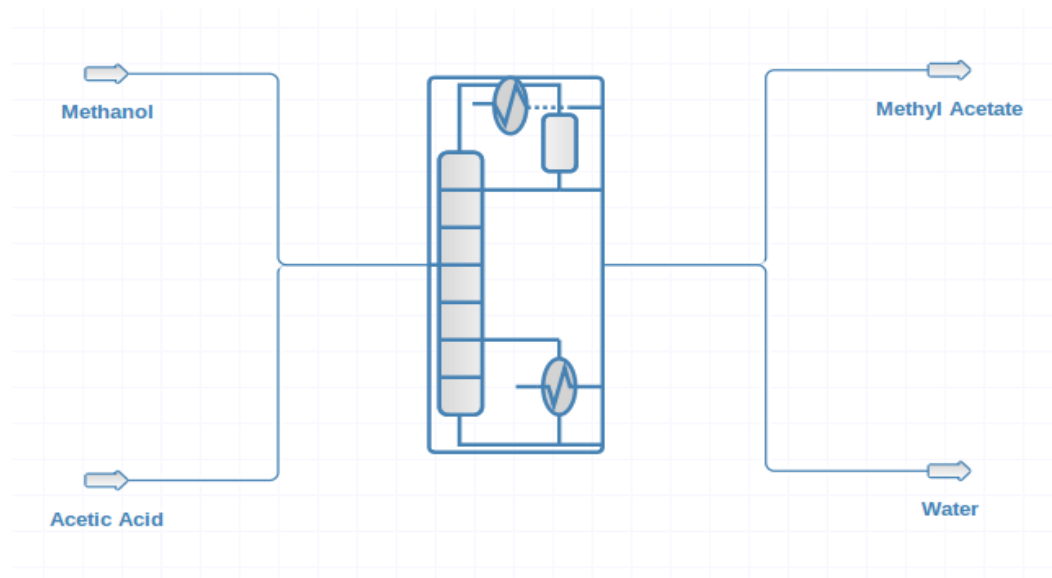

Fischer esterification is the formation of ester (along with water) when carboxylic acid is treated with alcohol, along with an acid catalyst. In the reaction, the hydroxyl group of carboxylic acid is replaced by the alkoxy group of alcohol. The reaction is an equilibrium reaction.

In this flow-sheet, methyl acetate is the ester being produced, a weak polar flammable liquid which is occasionally used as a solvent. Two separate streams of pure methanol and pure acetic acid of equal molar flow rate are fed into a reactive distillation column at 1 atm pressure and 298 K temperature. The reactive column used here has been ported from ChemSep, using the CAPE-OPEN Unit Operation and is a simple distillation column.

The UNIQUAC model of activity coefficient has been used to account for non-ideal vapor-liquid equilibrium. The Extended Antoine model has been used for vapor pressure. The values of interaction parameters have been adapted from literature. The reaction is an elementary, pseudo-homogeneous, reversible reaction. In a 40 stage simple distillation column, acetic acid is fed in the 3rd stage and methanol is fed in the 27th stage. The column is operated at a constant pressure. Methyl acetate is obtained as the top product with a composition of 98.7% (mol basis) at 330 K. Water is obtained as the bottom product with a composition of 99.5% (mol basis) at 373 K. The reflux ratio of the column is specified at 1.966 and the bottom product flow rate is specified at 49.65 kmol/h.

URL: <https://dwsim.fossee.in/flowsheeting-project/dwsim-flowsheet-run/37>

2.26 Process Development for the Production of Mono Propylene Glycol from Propylene Oxide

Author: Jayaram Ganesan

Institution: SASTRA Deemed University, Thanjavur

Mono Propylene Glycol (MPG) is an industrially important chemical, widely used in the manufacture of unsaturated polyester resin, food, drugs, cosmetics and personal care products. It is also known as

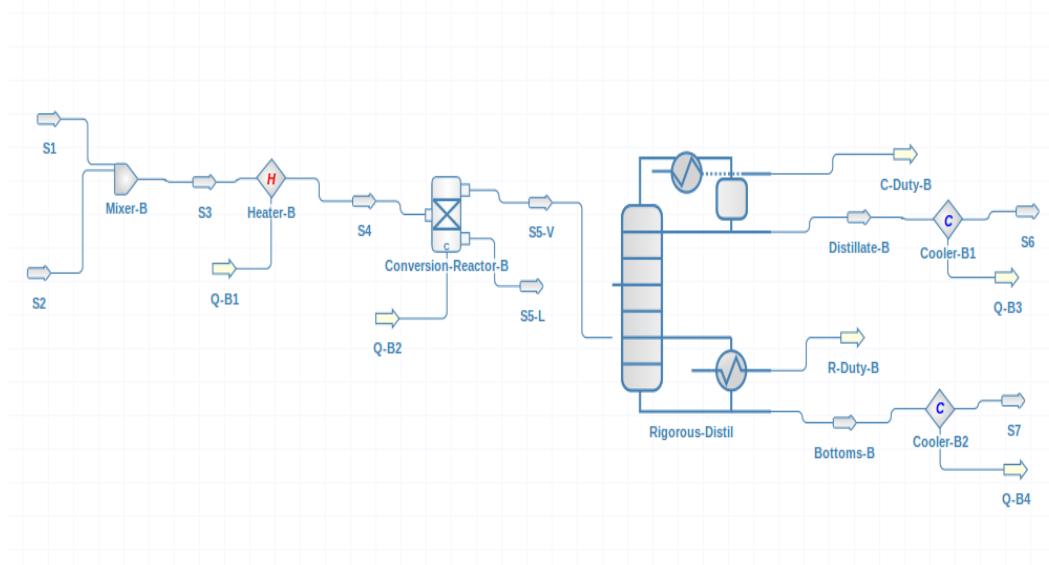

1, 2-Propanediol. It is a colorless organic liquid, with the molecular formula- $C_3H_8O_2$. MPG has a huge global demand, especially in the field of pharmaceuticals and in the food industry. The worldwide consumption of MPG was about 2.8 million tonnes in 2013. Dow, Lyondell Chemical Company and Shell Eastern Petroleum are the major players in the market. The present work focuses on the production of MPG by hydrolysis of Propylene Oxide (PO).

The process water and PO from storage are pumped into a buffer drum. The mixture is pre-heated to 200°C and then fed to the conversion reactor, in which the vapor phase hydrolysis of propylene oxide to MPG takes place. The exit stream from the reactor is fed to a distillation column, where PO, water and traces of MPG are recovered at the top stream and the rest is obtained as bottoms. Thus, 99% product is recovered in the bottoms of the distillation column. The product streams are cooled to room temperature and sent to the storage vessel.

URL: <https://dwsim.fossee.in/flowsheeting-project/dwsim-flowsheet-run/38>

2.27 Separation of Natural Gas

Author: Priyam Nayak

Institution: Indian Institute of Technology Bombay

One of the important processes in chemical engineering is the processing of natural gas. Moreover, improved production methods due to an increased supply and decreased cost of natural gas, have made the process much more significant. Though the composition of natural gas varies from source to source, it is mostly constituted by methane (85%) with a small amount of ethane, propane, n-butane, isobutane and heavier hydrocarbons. C_2 and heavier hydrocarbons are more valuable than methane and hence it is very important to recover them. C_2 and heavier hydrocarbons are called as 'Natural Gas Liquid'. Recovery is accomplished in a series of five distillation columns.

Recovery of hydrocarbons from the natural gas feed is achieved by using a series of distillation columns. First, methane is separated in a high pressure cryogenic distillation column using expansion. The column is called de-methanizer and is designed in a way to keep a low concentration of methane in its bottom product. The column is operated at 25 atm and 180 K. De-ethanizer is the second column, used in the process to recover ethane. The column operates at 21 atm and 264 K. Refrigeration is used in the condenser and the column is designed in such a way that the distillate only has a specified concentration of propane impurity.

De-propanizer is the third column, used in the process to recover propane as the distillate, operating at 17 atm and 322 K. Cooling water is used in the condenser and designed in such a way that the bottom

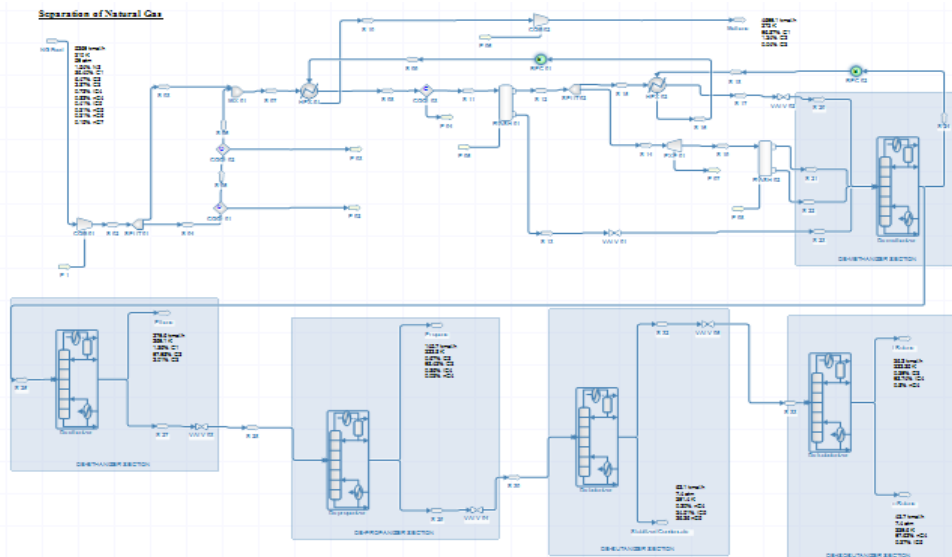

only has specified concentration of propane impurity. Debutanizer is the fourth column, used to carry n-butane and isobutane as overhead products for further separation in another column. Due to lowest relative volatility of iC_4/nC_4 , its separation is the most difficult. Hence this separation is performed after all the lighter and heavier components are removed. It also makes the process more economical. The column is operated with a reflux drum temperature of 322 K and 7.1 atm pressure.

The last column is the de-isobutanizer. It separates isobutane as the distillate and n-butane as the bottom. The column is designed in a way such that n-butane has a specific concentration as impurity in the distillate, and isobutane as impurity in the bottoms. The column is operated at 322 K temperature and 6.6 atm pressure. The Peng-Robinson thermodynamics model is employed in this flow-sheet.

URL: <https://dwsim.fossee.in/flowsheeting-project/dwsim-flowsheet-run/40>

2.28 Extractive Distillation of Toluene and Methylcyclohexane using Phenol

Author: Priyam Nayak

Institution: Indian Institute of Technology Bombay

Extractive distillation is the process of distillation that uses a high-boiling, miscible, non-volatile solvent, which doesn't form any azeotrope with the other components in the mixture. A solvent with a higher boiling point than that of feed mixture is chosen, so that the formation of a new azeotrope is impossible. MethylCycloHexane (MCH) along with toluene, forms a close boiling mixture and therefore, the conventional method of distillation cannot be carried out to separate them. Hence, Phenol is used as a solvent to separate them.

20 mol/s of the toluene and MethylCycloHexane (MCH) mixture in equimolar composition is fed to an extractive distillation column in its 25th stage. A stream of phenol, with the molar flow rate of 50 mol/s, is fed to the 10th stage of the column. On separation, MCH is obtained as the top product while the mixture of toluene-phenol is obtained as the bottom.

The extractive column has 40 stages. Further, the toluene-phenol mixture is sent to another distillation column called 'solvent recovery', to obtain toluene as the top product and to recover phenol from the bottom. The solvent recovery column has 20 stages and the feed enters at the 12th stage. The recovered phenol is then recycled to the makeup mixer. A pure stream of phenol enters the makeup mixer to act as excess phenol makeup, to maintain the constant molar flow rate of 50 mol/s, as feed to the extractive column.

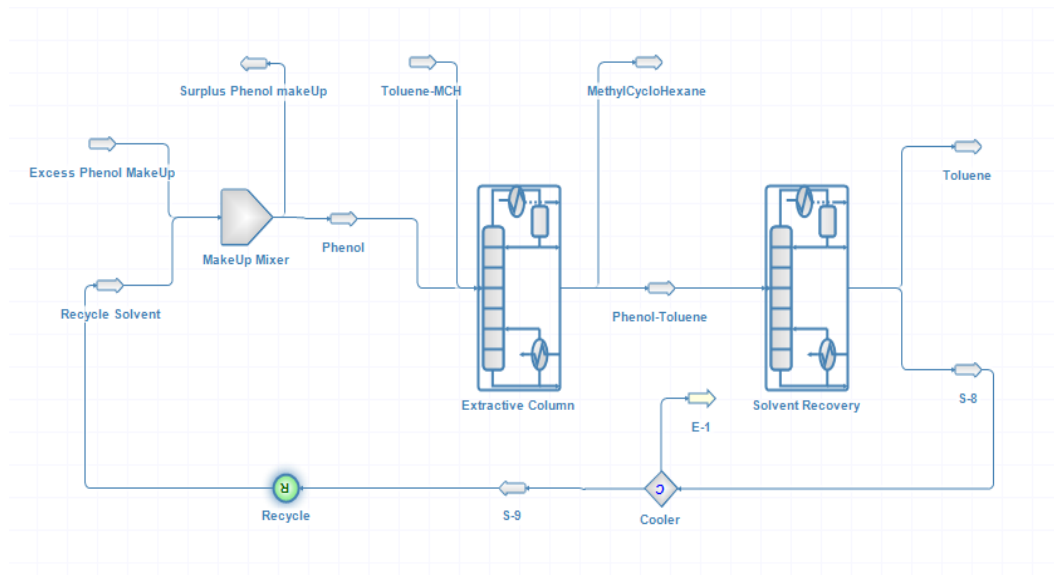

URL: <https://dwsim.fossee.in/flowsheeting-project/dwsim-flowsheet-run/43>

2.29 Production of Ammonia through Haber's Process.

Author: Indranil Banerjee

Institution: MVJ College of Engineering

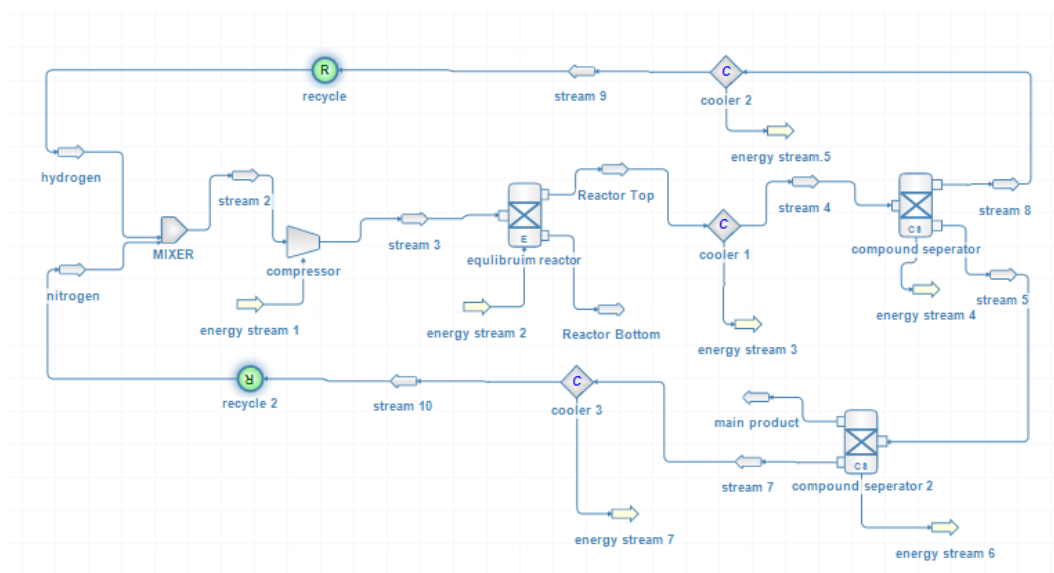

Ammonia is one of the most important chemicals used in industries for the commercial production of fertilizers, and for many other purposes. It contributes significantly to the nutritional needs of terrestrial organisms, by serving as the precursor to food and fertilizers. The global production of ammonia was 176 million tonnes in 2014.

The process starts with mixing the two streams of hydrogen at 1 bar, and nitrogen at 8 bars, which are introduced at 27 K. These are then fed to the compressor, where the pressure is increased by 10 bar. They are then introduced into the equilibrium reactor, where in the presence of an iron catalyst at

a temperature of around 850 K and at a pressure of around 100 bar, occurs an exothermic reversible reaction:

Ammonia is formed along with some unconverted hydrogen and nitrogen. The ammonia that is formed is then passed through a cooler, where it is cooled by extracting heat from it. Then, the stream, containing the mixture of ammonia, hydrogen and nitrogen, is sent to the component separator. Here, the upper stream consisting of hydrogen is recycled back to the main stream of hydrogen through a cooler, where the temperature is reduced from 857 K to 300 K. The other stream from the component separator, consisting of a mixture of nitrogen and ammonia, is given to another component separator. Here, the pure stream of ammonia comes out as the main product and the nitrogen is recycled back to the main stream through the cooler.

URL: <https://dwsim.fossee.in/flowsheeting-project/dwsim-flowsheet-run/29>

2.30 Process Development for the Production of Propylene Glycol Monomethyl Ether

Author: Ragul A S

Institution: SASTRA Deemed University, Thanjavur

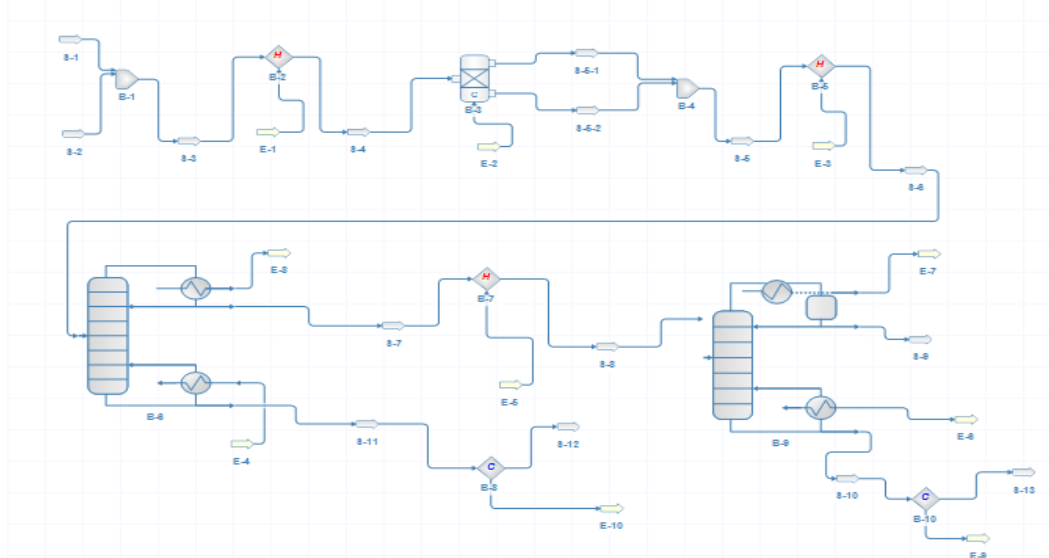

Propylene Glycol Monomethyl Ether (PGMME) is a methoxy alcohol derivative, classified under the p-series glycol ethers. PGMME is largely demanded in the sector of paints and coatings. It is also known as 1-Methoxy-2-Propanol. It is a colorless and a highly flammable liquid, with a molecular formula of $C_4H_{10}O_2$. The major producers of PGMME across the world are Dow Chemicals, Hualun Chemicals and Eastman. Manali Petrochemicals is the dominant producer of PGMME in India. The present work focuses on the production of PGMME by the reaction of methanol and PO in the presence of the tri-ethyl amine catalyst.

The process involves the reaction of Propylene Oxide (PO) and methanol (MeOH) in the presence of the tri-ethyl amine catalyst in a continuous flow reactor. The reaction is exothermic in nature, with the formation of a by-product- Di-Propylene Glycol Monomethyl Ether (DPGMME). The product stream from the reactor is sent to the first distillation column (Shortcut column, B-6) where large amounts of PO, MeOH and PGMME are recovered at the top, along with small traces of DPGMME. DPGMME is removed from the bottom. The distillate stream from the first distillation column is sent to the second distillation column (Rigorous distillation column, B-9) where the PGMME stream is recovered as the bottom. All outlet streams are cooled to an ambient temperature.

2.31 Synthesis of Methanol

Author: Nikhil Kodela and K. Pramod Kumar

Institution: National Institute of Technology Warangal

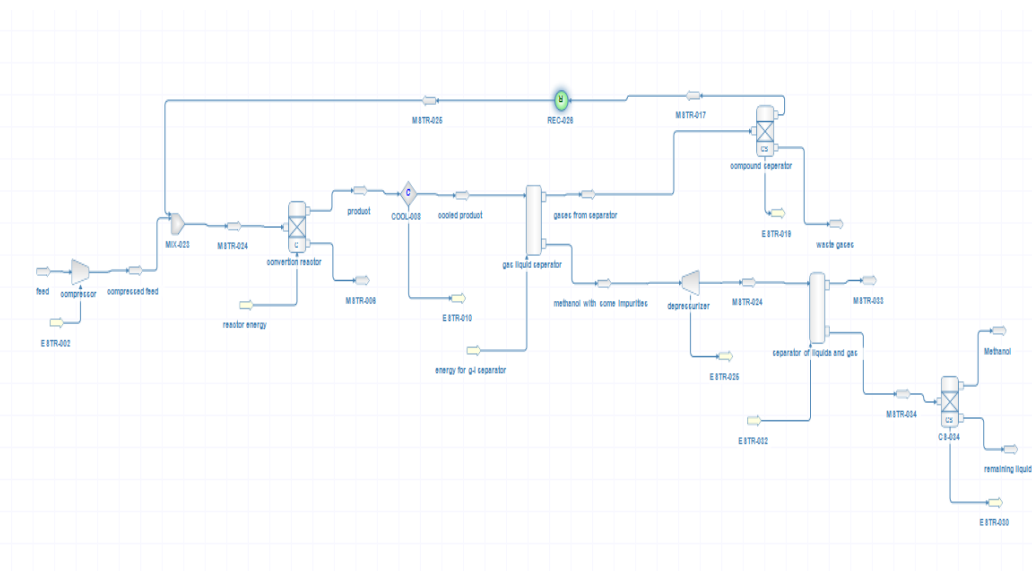

The hitherto dominating production method of methanol synthesis is through the synthesis gas process, first developed during 1920. A gas mixture of hydrogen and carbon monoxide (and also carbon dioxide) known as synthesis gas (syngas), is the basis for almost all methanol production today. The production of methanol basically consists of three main steps: syngas preparation, methanol synthesis and methanol purification

The flow-sheet used for methanol synthesis consists of a mixer to mix the recycle stream and feed stream, conversion reactor, the cooler to cool the products, separator to separate gases and the liquids, and a purifier to purify the methanol. First, the feed consists of H_2 and CO in the ratio of 2.25. The reactants are fed along with the recycling of CO and H_2 in to the conversion reactor.

The products from the reactor are then sent to a cooler unit, where the products are cooled. The gases and liquids that are formed by cooling are separated, and these gases are sent to get recycled. H_2 and CO are sent into the mixer to mix with the feed stream. The liquid products are then sent to a decompressor, to decompress them to 14atm. After decompressing, these are sent to the gas liquid separator to separate gases and liquids. The liquid products are sent to the (CS) compound separator, to separate methanol from the remaining components that are present. We get methanol as the product.

2.32 Production of Benzene via the Hydrodealkylation of Toluene

Author: Shailesh Agrawal

Institution: Visvesvaraya National Institute Of Technology, Nagpur

The process flow diagram for the process is shown in the figure. The fresh toluene feed (no.1) along with the recycle stream (no.11) is pressurized and mixed with hydrogen (no.3 and no. 5). The mixture

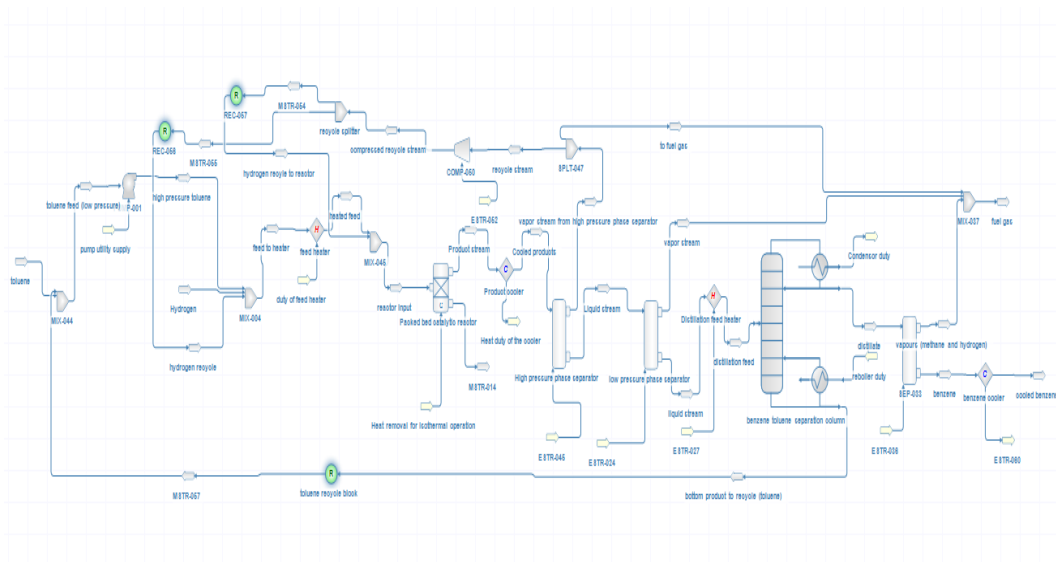

is fed to a heater (E-101), followed by the furnace heater (H-101) to increase the temperature to around 600°C . The heated stream (no.4) along with a small fraction of recycled hydrogen stream (no. 7) is introduced into a packed bed catalytic reactor (R-101). The reactor effluents are cooled and fed to phase separators (V-102 and V-103) to separate un-reacted hydrogen along with methane. A part of the separated gases is recycled back, and the rest is collected as fuel gas (no.16). The liquid stream (no. 10) from the second phase separator is fed to the distillation column after passing through the feed heater (E-103). The distillation column separates the light key component (benzene) which is subsequently cooled and stored (no.15). The bottom heavy component (toluene) is recycled back to the toluene vessel.

URL: <https://dwsim.fossee.in/flowsheeting-project/dwsim-flowsheet-run/47>

2.33 Esterification of Acetic Acid with 1-Butanol to N-Butyl Acetate

Author: Devesh Sharma

Institution: Pacific School of Engineering, Surat

Esterification is a chemical process used for making ester. The most common method of making esters is by heating carboxylic acid with an alcohol and removing water from it. Esters are normally produced by a batch process in industries, using mineral acid catalysts like H_2SO_4 .

The reaction is a reversible reaction. N-Butyl acetate is used as a flavoring ingredient and as a solvent in the production of lacquers and other products. It is also used in synthetic fruit flavoring.

Two pure streams of 1-butanol and acetic acid were fed into reactive distillation column at 50 kmol/hr, 1 atm and 298.15 K. The reactive distillation column was introduced from CAPE-OPEN, and Chem-Sep was used to input the data. In a 34 stage simple distillation column, acetic acid was fed at stage 13 and 1-butanol at stage 16. Water, and a small fraction of N-butyl acetate, is obtained from top and from the bottom. To separate the water and N-butyl acetate, a decanter is used. The decanter was introduced from CAPE-OPEN using Chem-Sep data. The reflux ratio to operate the column is 2. The molar flow rate of the product (N-butyl acetate) is 50.036 Kmol/hr and for the by-product (water) is 49.96 Kmol/hr.

URL: <https://dwsim.fossee.in/flowsheeting-project/dwsim-flowsheet-run/48>

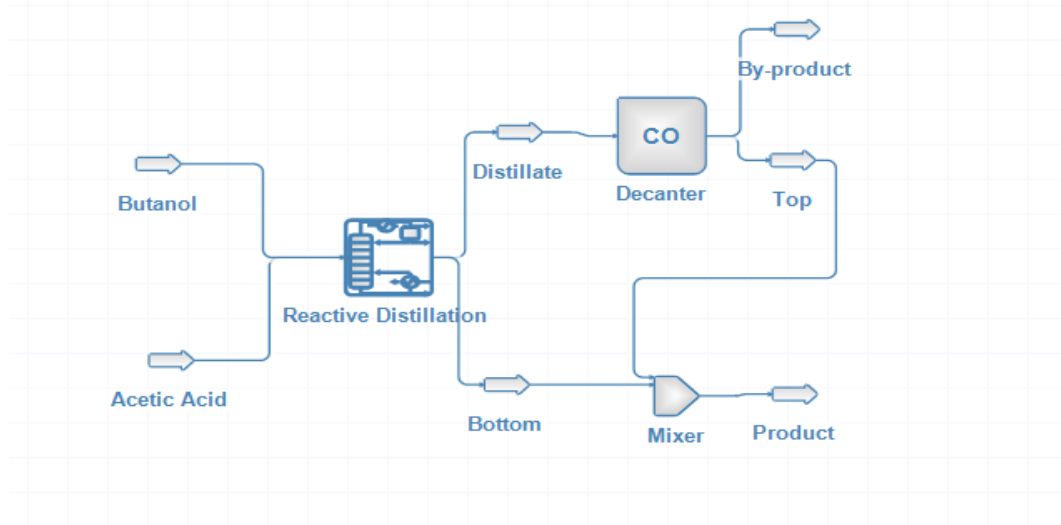

2.34 Cumene Production from Benzene And Propylene

Author: Priyam Nayak

Institution: Indian Institute of Technology Bombay

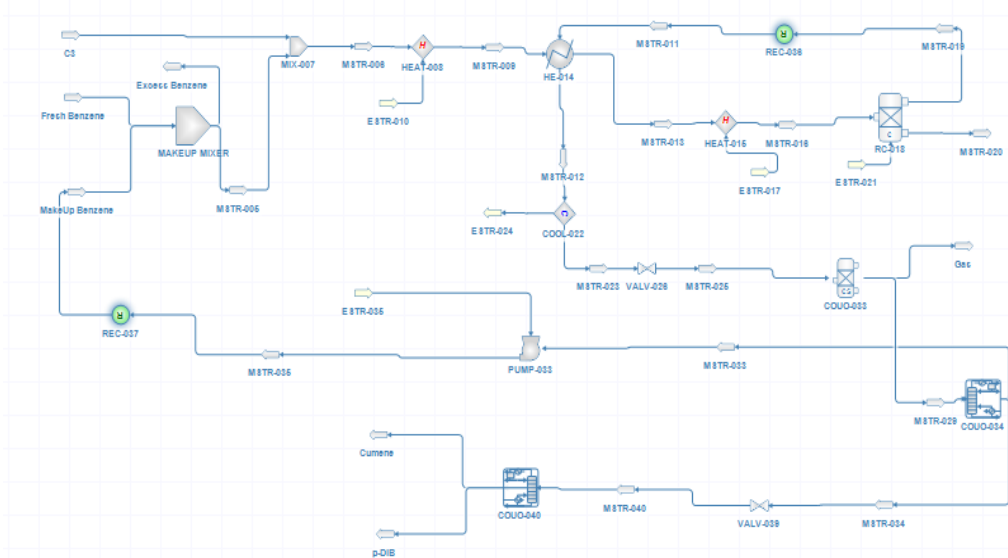

Cumene, also known as isopropylbenzene, is used as a thinner in paints, lacquers and enamels. It is a component of high octane motor fuels. Cumene is used to manufacture other chemicals such as phenol, acetone, acetophenone and methyl styrene. It is also used in the manufacturing of rubber, iron and steel, and pulp and paper.

Fresh feed streams of benzene and mixed C3 enter the process as liquids. Feed streams after being mixed, are fed to the vaporizer and they leave at 483.15 K and 25 bar. This is pre-heated in the two heat exchangers. The first recovers heat from the hot reactor, effluent at 692.15 K. The second adds additional heat to bring the reactor inlet temperature up to 647.15 K. Then, the stream enters a tubular reactor which leaves as a reactor effluent at 692 K and is cooled to 607K through the feed effluent heat exchanger. The reactor effluent is further cooled down to 363 K, using a condenser, and is sent to a flash drum by reducing the pressure to 1.7 atm through a pressure reduction valve.

The gas stream obtained from the tank is used as fuel and the liquid stream is fed to the first distillation column. The first column comprises of 15 stages, with the feed being fed in the 8th stage. Benzene is obtained as distillate in the top, which is recycled back to the reactor. The stream obtained as bottoms is fed to another distillation column. The second column has 20 stages, and the feed is sent in the 12th stage. Cumene of higher purity is obtained as distillate and p-diisopropylbenzene is obtained in the bottoms

URL: <https://dwsim.fossee.in/flowsheeting-project/dwsim-flowsheet-run/44>

2.35 Air Separation Unit

Author: Priyam Nayak

Institution: Indian Institute of Technology Bombay

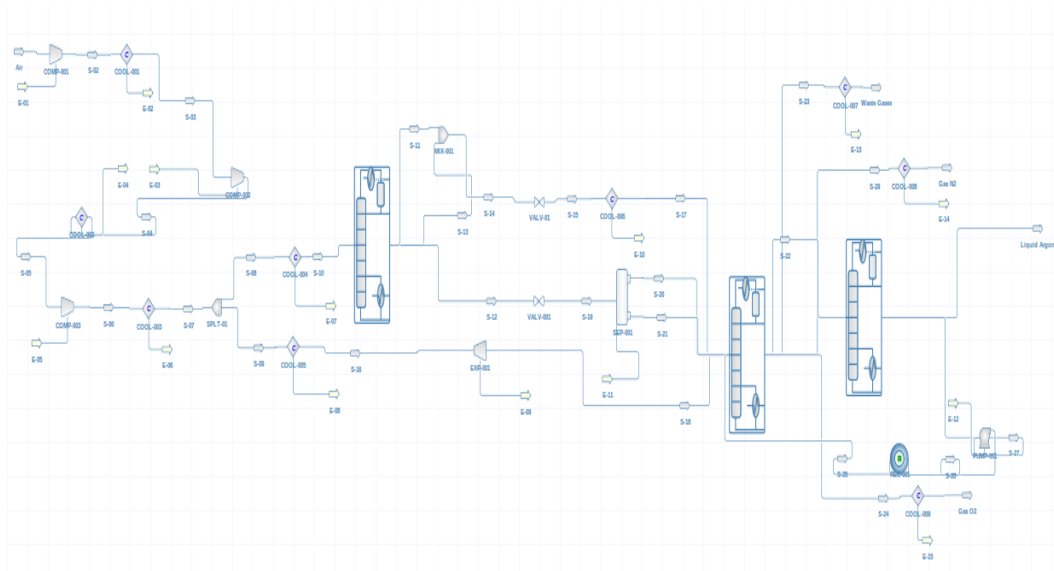

Air separation process is an integration of separation columns and the heat exchanger. The process is driven by compressing air at the inlet of the unit. Compressed air is cooled and partially liquefied against the leaving product streams. In the first column, nitrogen is separated at a pressure of 6 bar and then is condensed against boiling oxygen, at a pressure of around 1.2 bar. In the high pressure column, the liquid bottom product is rich in oxygen. The rich liquid is cooled using the Joule-Thomson effect to run the condenser of a side rectifier that separates argon from oxygen. It is fed with vapor side draw from low pressure column. A part of the air leaves the unit as a waste stream, due to the additional requirement of cooling which is obtained using the Joule-Thomson effect in an expander. This feeds compressed air directly into the low pressure column. Gaseous oxygen, nitrogen and liquid argon are obtained as products.

The purity of gaseous oxygen ranges from 97.5% to 99.5%. The Peng-Robinson Model was used to solve the flow-sheet with the binary interaction parameters as $N_2/O_2 = -0.0133$, $N_2/Ar = -0.0026$, $O_2/Ar = 0.0089$. The liquid stream from the argon column is fed back to the low pressure column. This serves as a tear stream for the flow-sheet.

URL: <https://dwsim.fossee.in/flowsheeting-project/dwsim-flowsheet-run/62>

2.36 Extractive Distillation of Isopropanol and Water System using DMSO as Entrainer

Author: Koona Prabhu Teja

Institution: National Institute of Technology Karnataka, Surathkal

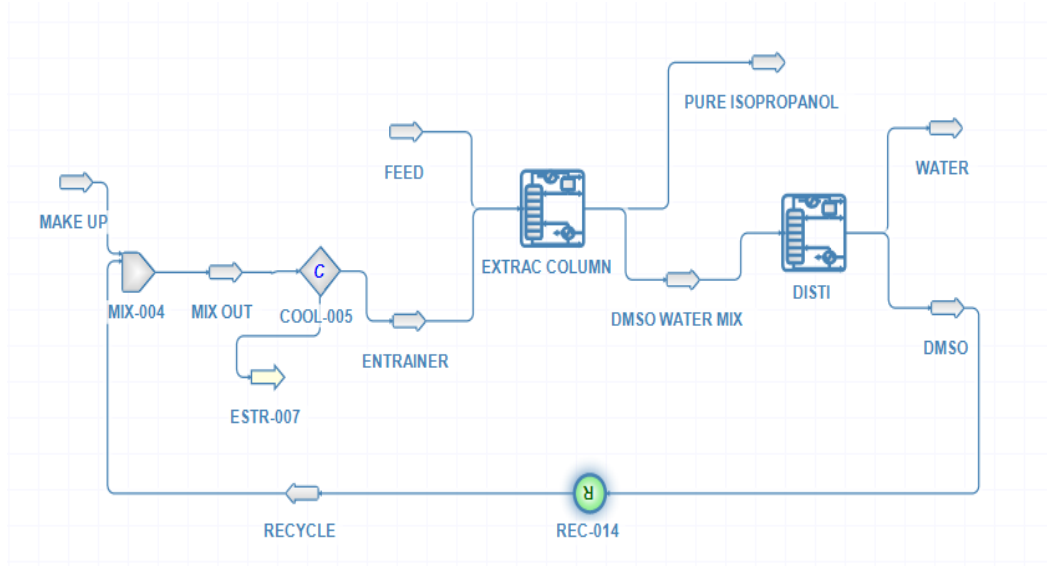

The demand of Isopropyl alcohol (IPA) is projected to increase with respect to its application as a solvent in automobile industries. It is also used along with propyl alcohol as a cleaning solvent. It forms a low boiling hetero-azeotrope with water. Methods for the recovery of IPA were suggested, which involves bringing the feed close to azeotropic conditions and subsequent separation through a decanter. However, this method involves multiple steady states, sensitivity in the selection of thermodynamic models, a longer time lag and non-linear dynamics that interferes with controlling the feed disturbances. Extractive distillation with Dimethyl Sulfoxide (DMSO) introduces a higher boiling mixture and an increased separation factor which is feasible for separation.

An equi-molar mixture of isopropanol/water is fed to the 35th stage of the 41 stage extractive distillation column with the solvent DMSO (Di-Methyl Sulfoxide) fed to the 7th stage. The presence of the entrainer alters the relative volatility between the two, causing pure IPA to move towards the top and the DMSO/Water mixture towards the bottom of the column. The mixture is fed into the 9th stage of a 24 stage recovery column to produce almost pure water at the top and an almost pure solvent at the bottom. It is recycled back to the extractive distillation column and merged with an additional pure make-up stream, to account for the solvent losses.

URL: <https://dwsim.fossee.in/flowsheeting-project/dwsim-flowsheet-run/42>

2.37 Extractive Distillation of Acetone-Methanol Mixture using Dimethyl Sulfoxide

Author: Koona Prabhu Teja

Institution: National Institute of Technology Karnataka, Surathkal

Acetone is used as a direct solvent and as a pioneer to the production of Methyl Methacrylate (MMA), Methacrylic Acid, bisphenol-A, aldol chemicals, to name a few. The use of MMA in LCD and polycarbonate dental fillings from bisphenol, play an indirect role of demand for acetone in consumer

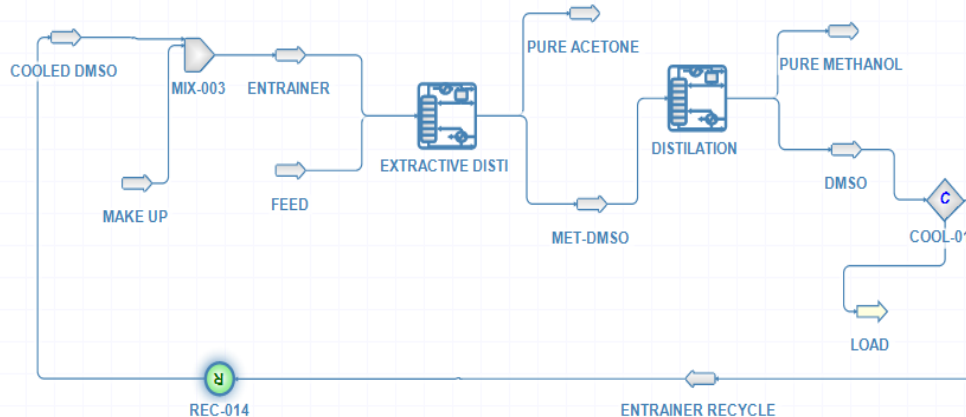

electronics and industrial chemicals. Acetone and methanol have very similar normal boiling points (329.2 K and 337.5K) and form a homogeneous minimum boiling azeotrope at 1atm, with a composition of 77.6 mol% acetone at 328 K.

Three solvents that have different normal boiling points (373 K for water, 464 K for DMSO, and 405 K for chloro-benzene) have been explored. The first and the second solvent drive the acetone overhead, while chloro-benzene drives the methanol overhead in the extractive column.

540 kmol/hr of an equal molar acetone -methanol mixture is fed to 24th stage of a 36th stage extractive distillation column. The entrainer from the recovery column, along with the makeup stream, is fed to the 4th stage giving an overhead pure acetone. The DMSO, heavy key (methanol) along with traces of acetone, is fed to the 8th stage of a 16th stage entrainer recovery column. High purity methanol is obtained at the overhead with pure DMSO at the bottom, which is recycled back to the extraction column.

URL: <https://dwsim.fossee.in/flowsheeting-project/dwsim-flowsheet-run/65>

2.38 Heterogeneous Azeotropic Distillation of Ethanol and Water

Author: Madhur Vachhani

Institution: Pacific School of Engineering, Surat

EtOH is naturally produced by the fermentation of sugars by yeasts, or via petrochemical processes. Its chemical formula is C_2H_6O . The first use of ethanol was to power an engine in 1826, and in 1876, Nicolaus Otto, the inventor of the modern four-cycle internal combustion engine, used ethanol to power an early engine. Ethanol is mostly used in the beverage industry. Other industries in which ethanol is used are paint, pharmaceuticals, etc.

EtOH and water azeotrope mixture (0.87 EtOH and 0.13 H_2O) at 100 Kmol/hr and temperature 311K is fed to the distillation column at stage 1. A mixture of EtOH, H_2O and benzene from the make-up mixer is also fed to the column at stage 5. From the bottom of column, a stream of ethanol is obtained, which has 0.99 EtOH at 65.49Kmol/hr. A stream from the bottom of decanter is fed to the second distillation column at stage 1. From the bottom of the second distillation column, a stream is obtained having 0.99 mol fraction of water at 18.26 kmol/hr. Top products from both the columns are fed to a mixture, followed through a cooler. The cooled stream is fed to a decanter.

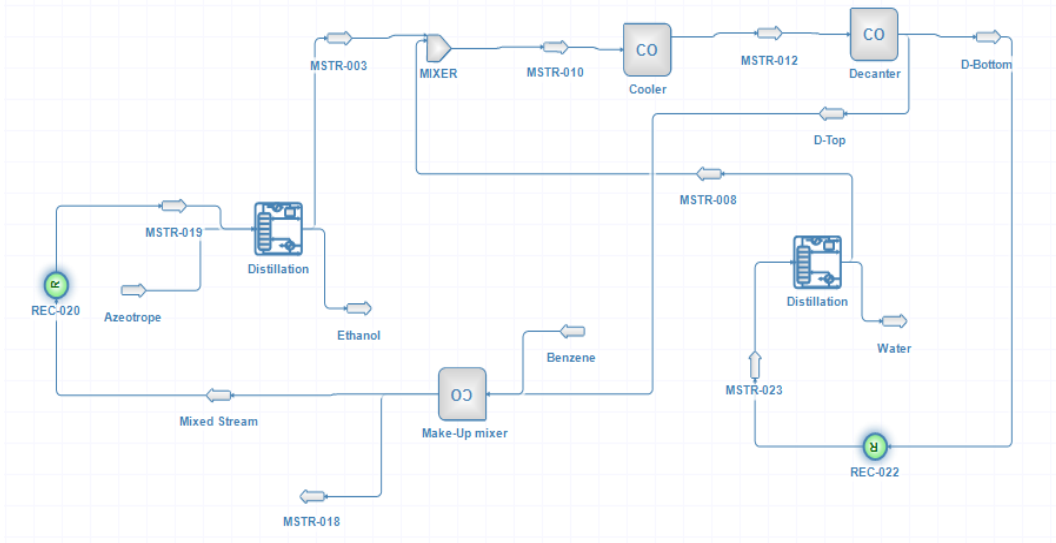

URL: <https://dwsim.fossee.in/flowsheeting-project/dwsim-flowsheet-run/52>

2.39 Production of Formalin from Methanol

Author: Ankit Ashok Kamdi

Institution: Visvesvaraya National Institute of Technology, Nagpur

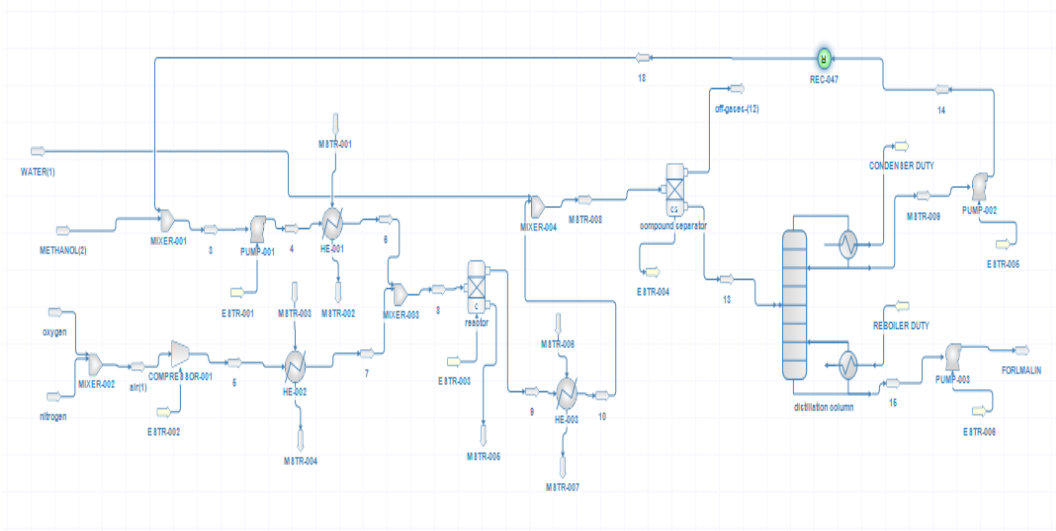

Formalin (37 wt% of formaldehyde in water) is majorly produced from methanol. Fresh Methanol (stream 2) mixes with recycled methanol (stream 18) in the mixer (mixer-001) and is pumped by pump (PUMP-001) and then passed through the heat exchanger to vaporized methanol. Stream 6 is at temperature 423.15 K and 314.7 kPa pressure. Fresh air, which is a mixture of oxygen and nitrogen, is available at 250°C and 1 atm. It is compressed (COMPRESSOR001) to 300 kPa and is preheated by passing through heat exchanger (HE-002) to a temperature of 200°C and is mixed with vaporized methanol from stream 6 in the mixer (MIXER003) with is then fed to a reactor.

An exothermic reaction occurs in the reactor which is operated at a defined outlet temperature with an energy stream (ESTR-003). Conversion of methanol is around 80% for an oxidation reaction and 25% for a decomposition reaction. The output of the reactor is again sent to the heat exchanger (HE-003), which decreases the temperature of the stream to 360 K. The outlet of the heat exchanger (stream 10) is mixed with water (stream 1) in a mixer (MIXER-004). Then, it is given to the compound separator, where the hydrogen produce during the decomposition of methanol is separated, along with nitrogen present in the air, utilizing the energy stream (ESTR-004).

Some traces of formaldehyde, methanol and oxygen are also separated in the separator. Now, the outlet of the separator is given to the distillation column, where the separation of methanol from the reaction mixture takes place. The condenser and reboiler duties are attached to the column. The heavy component is water, and the light component is methanol. Formaldehyde will follow water, as it is associated with it. The top product from the column that is the distillate is pumped through a pump (PUMP-002) which is passed through a recycle loop and sent to the mixer (MIXER-001). The bottom product is collected and pumped through to a higher pressure. The composition of the product is around 32 mol% of formaldehyde, with some traces of methanol present.

URL: <https://dwsim.fossee.in/flowsheeting-project/dwsim-flowsheet-run/61>

2.40 Claude Refrigeration Of Methane

Author: Nemmani Rama Gopal

Institution: Bapatla Engineering College

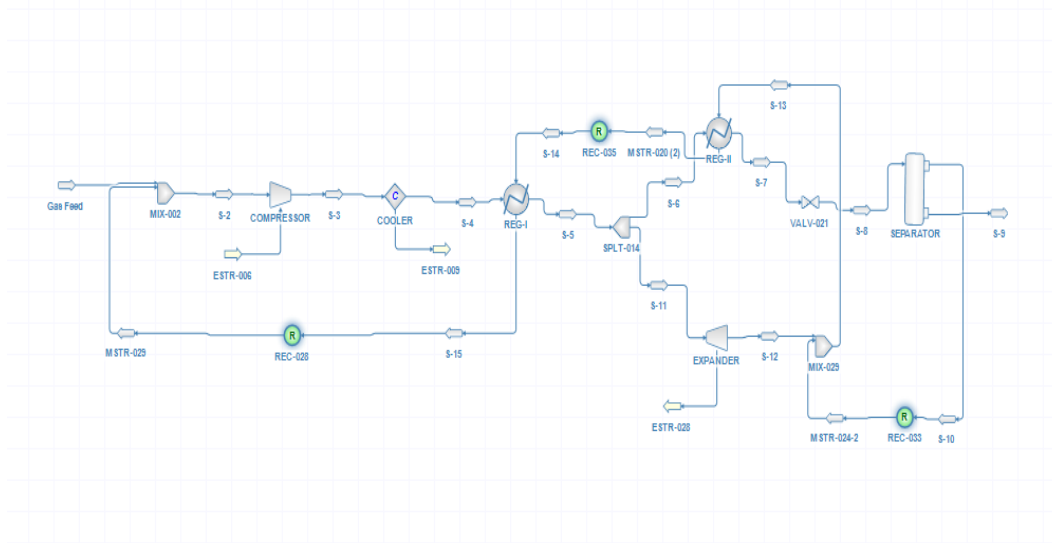

Natural gas is predominantly methane. Liquefying natural gas has several advantages, the main one being its ease of transportation and safety. Claude refrigeration cycle is the basis of various improvisations for liquefying natural gas. The Claude cycle consists of all three processes for liquefying gases, namely, isobaric cooling, throttling and expansion, from which work is obtained.

The flow-sheet requires three recycle blocks. The objective is to find what fraction of stream that enters the regenerative system is liquefied. The lesser the temperature before throttling, more is the fraction of methane liquefied. One can also study the effect of split ratio on liquefaction process.

URL: <https://dwsim.fossee.in/flowsheeting-project/dwsim-flowsheet-run/56>

2.41 Production of Cyclohexane through Catalytic Hydrogenation of Benzene

Author: Sruti Dammalapati

Institution: National Institute of Technology, Tiruchirappalli

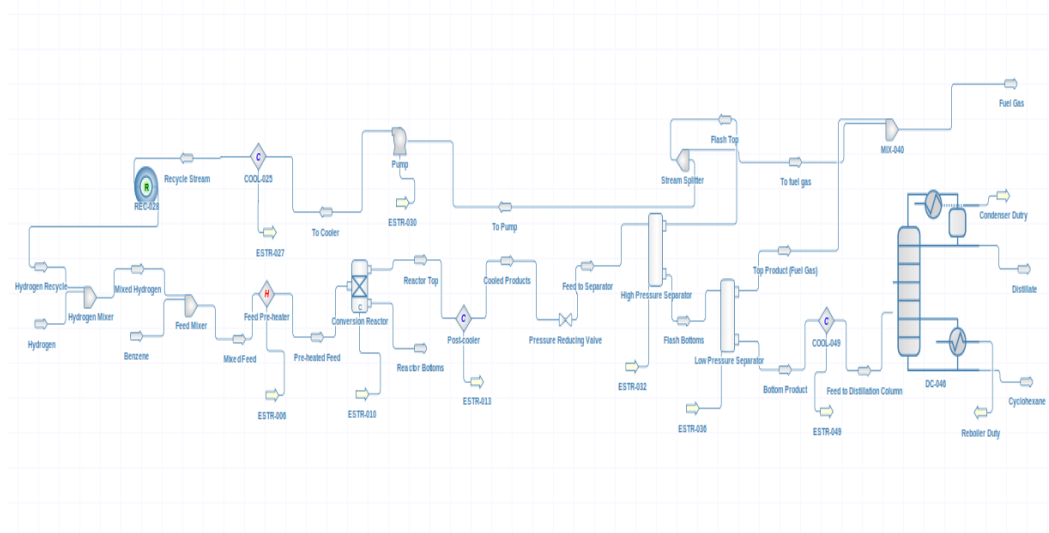

Cyclohexane is industrially produced from Benzene, as it is not a naturally available resource. Cyclohexane undergoes oxidation reactions yielding cyclohexanone and cyclohexanol, which are precursors for the production of adipic acid and caprolactum. Caprolactum is the raw material used for producing polymer Nylon-6. Benzene reacts with a mixture of hydrogen and methane in contact with a nickel based catalyst producing cyclohexane. The conversion of this vapour phase reaction is almost 99%.

Fresh benzene (370 kmol/h) and excess hydrogen (1460 kmol/h) is preheated to a temperature of 422 K and sent to a packed bed reactor. A vapor phase reaction in the reactor at 497 K, which converts benzene to cyclohexane through the catalytic hydrogenation of benzene. The conversion of this reaction is about 99%. The reactor products are cooled to 370 K and sent through a pressure reduction valve, which reduces the pressure of the stream from 26 atm to 24 atm.

A two stage separator separates the product cyclohexane from the unreacted hydrogen and methane first at a high pressure (24 atm) and then at a lower pressure (3 atm). The unreacted hydrogen-methane mixture is recovered from the top of the flash column, and is sent to a splitter having a splitting ratio of 9:1. The smaller stream is sent as a recycle stream and mixes with fresh hydrogen, while the rest is drawn out as fuel gas for incinerators. The bottom stream of the flash column having 99% (wt/wt) cyclohexane is sent as feed to a distillation column for further purification. The column consists of 12 stages operating at a reflux ratio of 5:1. The residue from the column has our desired product, with a purity of 99.5% (wt/wt) cyclohexane.

URL: <https://dwsim.fossee.in/flowsheeting-project/dwsim-flowsheet-run/80>

2.42 Dehydration of Ethanol using Glycerol as Entrainer

Author: Koona Prabhu Teja

Institution: National Institute of Technology Karnataka, Surathkal

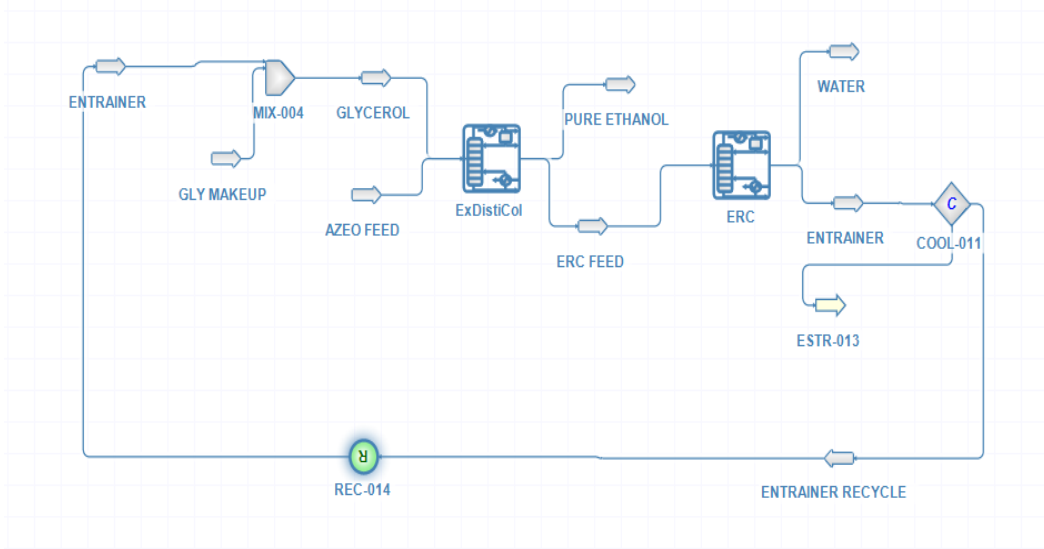

Ethylene glycol is cheap, due to its extensive production as a part of manufacturing bio diesel. It also has the potential to modify the liquid-vapour equilibrium, which helps in removing the water-ethanol azeotrope. Ethanol–water mixture at atmospheric pressure has a minimum-boiling homogeneous azeotrope at 78.1°C of composition 89 mol% ethanol. Thus, this mixture cannot be separated in a single distillation column, and if it is fed to a column operating at atmospheric pressure, the ethanol purity in the distillate cannot exceed 89 mol% while high purity water can be produced from the bottom.

100 kmol/hr of an azeotropic feed is sent to the 10th stage of an 18 stage extractive distillation column. The entrainer make up, along with the recycle from the entrainer recover column, is sent to the 3rd stage. Glycerol changes the liquid activity coefficients, thereby the relative volatility leading to pure ethanol to the top and Glycerol- water mixture to the bottom. They are sent to the 4th stage of a 7 stage recovery column operating at a reduced pressure to separate the respective entrainer and water. Glycerol at the bottom is cooled, recycled back to the extractive column, and a small makeup is added to account for entrainer losses.

URL: <https://dwsim.fossee.in/flowsheeting-project/dwsim-flowsheet-run/91>

2.43 EthylBenzene production from Ethylene and Benzene

Author: Pragneshsinh Sindha

Institution: Pacific School of Engineering, Surat

Ethylbenzene is almost exclusively (99%) used as an intermediate, for the manufacture of the styrene monomer. Styrene production, which uses ethylbenzene as a starting material, consumes approximately 50% of the world's benzene production. Less than 1% of the ethylbenzene produced is used as a paint solvent, or as an intermediate for the production of diethylbenzene and acetophenone. Ethylbenzene was first produced on a commercial scale in the 1930s in Germany and United States. Almost all ethylbenzene is produced commercially, by alkylating benzene with ethylene, either in the liquid phase with aluminium chloride catalyst or in the vapor phase with a synthetic zeolite.

The ethylbenzene process involves the reaction of benzene with ethylene to form the desired ethylbenzene (EB) product. Herein, the undesirable product DEB (di-ethylbenzene) is also formed due to a side reaction. The benzene stream is fed, at rate of 630.6 kmol/h at 320 K, to the mixer in which the ethylene stream also mixed with the same molar flow rate at 1 atm pressure. The well mixed slurry is fed to conversion reactor-1 at 20 atm pressure, where EB and DEB is formed. Further, this slurry is fed to conversion reactor-2, with a recycle stream of DEB at 19 atm pressure, where DEB reacts with benzene

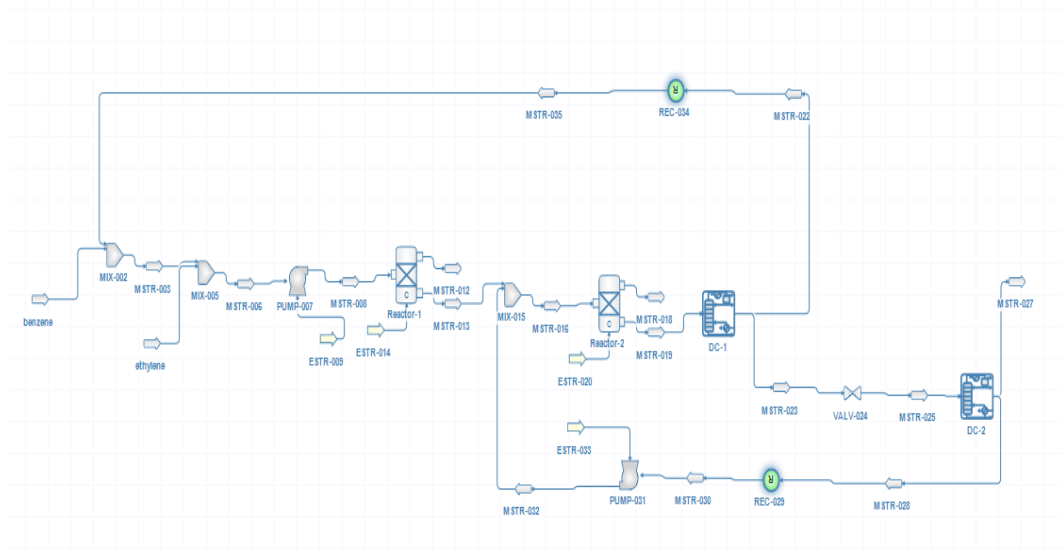

to give EB. Here, for the separation of EB, two distillation columns are used. In the first DC-1 column, benzene is recovered as distillate and recycled to the mixer and at the bottom, EB and DEB are found in proportion, which is further separated in the DC-2 column. In the DC-2 column, EB is found in the top product, at the rate of 630.6 kmol/h and DEB is found as a bottom product, which is recycled to the reactor-2 at 281.9 kmol/h.

URL: <https://dwsim.fossee.in/flowsheeting-project/dwsim-flowsheet-run/54>

2.44 Production of Cumene: Demonstration of Closed Cycle Utility Loop

Author: K. Gopinath

Institution: SASTRA Deemed University, Thanjavur

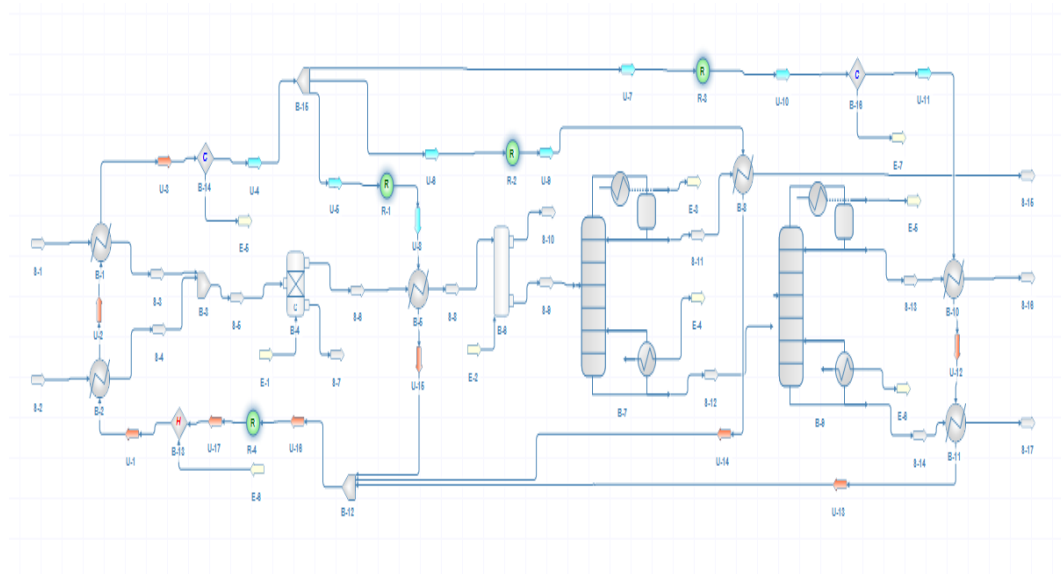

Cumene or Isopropylbenzene is an aromatic compound manufactured from propylene and benzene. Essentially, most of the cumene produced is further converted to cumene hydroperoxide. Cumene hydroperoxide is an intermediate in the synthesis of other industrially valuable chemicals, such as phenol and acetone. Cumene is a clear colorless liquid with an aromatic odor. Mostly cumene is produced through the Q-max (UoP, Inc.) wherein benzene and propylene are converted to high quality cumene using a zeolite catalyst. In the present work, simulation of a typical cumene production process through direct alkylation of benzene with propylene is performed.

Alkylation reaction converts benzene and propylene to cumene and di-isopropylbenzene in the presence of the zeolite catalyst. It is an endothermic reaction and occurs at a high temperature 250°C and at atmospheric pressure. The feed stream consisting of 1:1 molar ratio of benzene and propylene is pre-heated to 250°C and is fed to the reactor. The reaction occurs in the vapor phase. The exit stream from the reactor is cooled to a temperature below the boiling point of benzene. The stream is then passed to a flash column operated at vacuum condition of 0.96 atm. The propylene is recovered, as vapors stream along with some traces of benzene. A liquid stream from the flash column is fed to the primary distillation column. The primary column removes maximum amount of Benzene as distillate. The bottom stream from the primary distillation column is further sent to the secondary column to separate cumene and di-isopropylbenzene. Cumene, of 98% purity, is obtained as the distillate stream. It is then cooled to an ambient condition. Steam and water are used as heating and cooling utility streams in the process. Energy recovery is achieved by the closed cycle utility loop.

URL: <https://dwsim.fossee.in/flowsheeting-project/dwsim-flowsheet-run/95>

2.45 Methanol Synthesis from Syngas as described by Luyben

Author: Pragneshsinh Sindha

Institution: Pacific School of Engineering, Surat

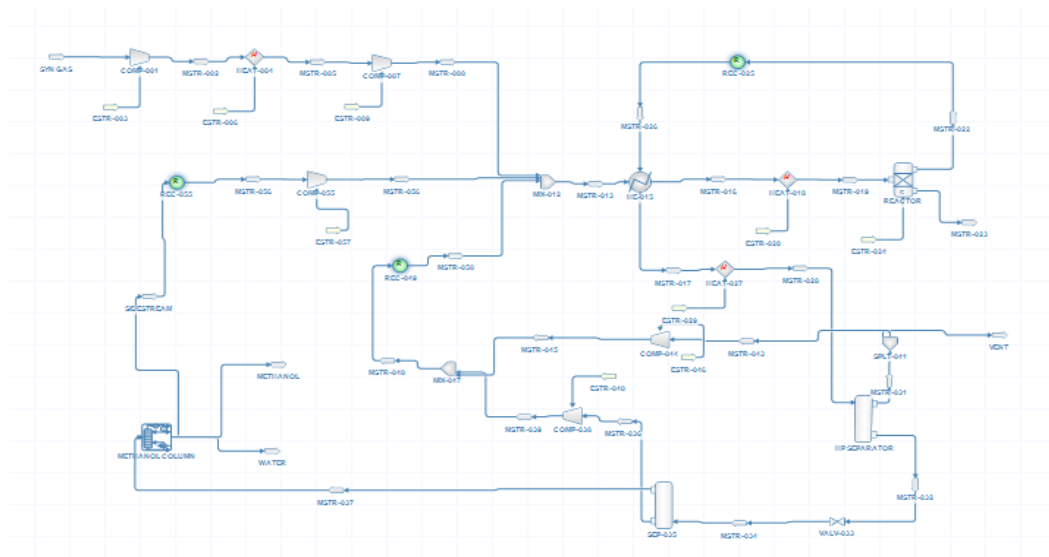

In the present day, methanol is considered to be an important fuel because it may provide various petroleum based-liquid fuels and its extensive used is done because of its availability. It can be formed by any renewable biomass hydrocarbon source, by partial oxidation to produce synthesis gas which is then converted into methanol. Here, simulation is carried out for a process which converts synthesis gas into methanol. The process conversion reactor is used to make hydrogen react with the carbon monoxide and carbon dioxide in the synthesis gas to produce methanol.

In this process, a fixed amount of synthesis gas is used for the feed. The “Peng-Robinson” property model is used, except in the distillation column. The process can be divided into four sections: (1) Compression and Reactor Preheating, (2) Reactor, (3) Separator, Recycle, and Vent, (4) Flash and Distillation

During compression, the synthesis gas at 51.2 bar is compressed in a two-stage compression system to 110 bar. Then, three recycle gas streams are added, and the gas stream enters the heat exchanger at 53.78°C. Here, the reaction conversion reactor is used, in which two reactions are carried out with 64% and 17% conversion of carbon monoxide and carbon dioxide respectively. After the complete reaction, the reactor effluent is cooled to 175.51°C in heat exchanger. It is further cooled to 38°C. Then, most of the vapor stream is compressed back to 110 bar and fed into a high pressure separator, from which a small fraction is vented off at a flow rate of 840 kmol/h. For removing light components from the stream flash, a separator is used, which operates at 2 bar. The liquid from the separator is fed to a 42-stage distillation column at stage 27. The column operates at 1 bar; a small vapor side stream from the column is recycled and is compressed back to 110 bar. From the column, highly pure methanol (about 99%) is obtained as a top product, and as the bottom (99%), water is obtained.

URL: <https://dwsim.fossee.in/flowsheeting-project/dwsim-flowsheet-run/98>

2.46 Separation of Acetonitrile-Methanol-Benzene Ternary Azeotrope

Author: Koona Prabhu Teja

Institution: National Institute of Technology Karnataka, Surathkal

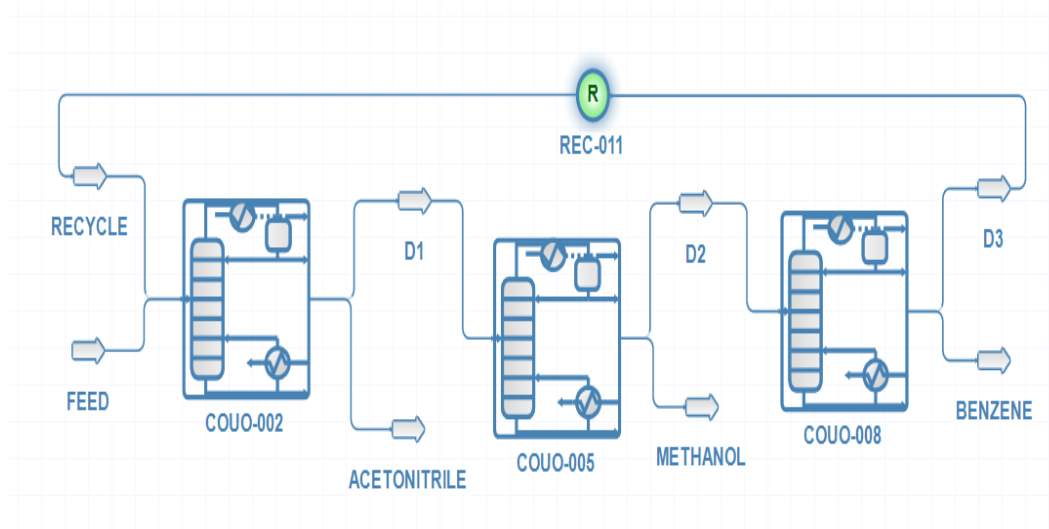

A complex and common ternary mixture of acetonitrile-methanol-benzene is encountered in chemical and pharmaceutical industries. Acetonitrile is used in lithium ion batteries, methanol (with the recent implementations to blend with petrol) is used to mitigate pollution and benzene is used in the polystyrene industries. Exposure to these chemicals causes irritation of the central nervous systems. Therefore, it is necessary to separate and reuse these chemicals, in order to protect the environment and to conserve resources. It is difficult to attain this separation through conventional distillation, due to the presence of a ternary azeotrope with varied distillation boundaries.

The influence of pressure on the azeotropic composition and temperature is a decisive factor and residue curve maps, at different operating pressures, are used to ascertain the optimization parameters

for this multi-component separation. A pressure swing moves the distillation boundaries that lie between the corresponding purity values of the desired products, thereby making the separation feasible.

The process consists of 3 pressure swing columns (referred to as C1, C2, C3) operating at 608-101.326-608 KPa pressures respectively. 1000 kg/hr of feed (0.7 M - 0.2A- 0.1B) is fed to the 37th stage of a 47 stage distillation column (C1) along with the recycled stream of the C3 that is fed to 28th stage. The bottom has pure acetonitrile, while the distillate (D1) is sent to C2 where it is faced with a reduced pressure. D1 is fed to the 18th stage of a 50 stage column with the bottoms yielding pure methanol and overhead (D2) fed to C3. D2 is fed to the fourth of 14 stage column where the bottoms is pure benzene and the overhead is recycled back to C1. The residue curve map for the compositions at the given pressure is shown below.

URL: <https://dwsim.fossee.in/flowsheeting-project/dwsim-flowsheet-run/99>

2.47 Tetrahydrofuran-Water Pressure Swing Azeotropic Distillation

Author: Harshil B. Vekariya

Institution: Pacific School of Engineering, Surat

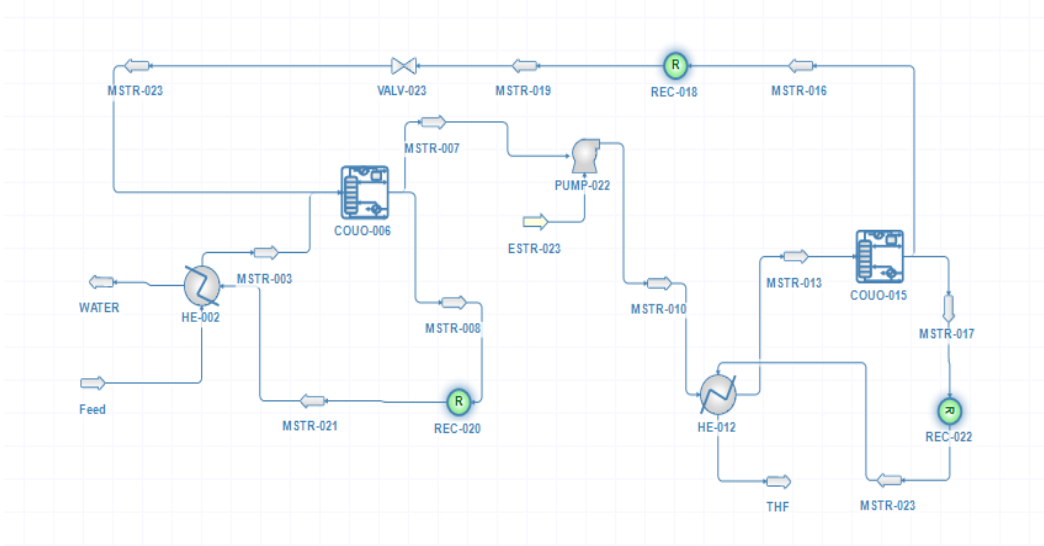

Simulations were performed to obtain highly pure tetrahydrofuran (THF) with over 99.9 mol% from the mixture of THF and water. Pressure swing distillation (PSD) was used, since the azeotropic point between tetrahydrofuran and water can be varied with pressure. A commercial process simulator, PRO/II with PROVISION release 8.3, was used for simulation studies. The Wilson liquid activity coefficient model was used to simulate the low pressure column, and the Peng-Robinson equation of state model was added to correct the vapor phase non-idealities for modelling of the high pressure column.

The water pressure swing azeotropic distillation process involves the separation of tetrahydrofuran (THF) and the water mixer, to form the desired water product and tetrahydrofuran product. No side products are produced during the process. Here, the mixer of raw materials is fed to the heat exchanger1 (H/E1) with 2000kmol/h at 308K and 1 atm pressure. The outlet of H/E1 is fed to the distillation column1 (DC1) and the top product of DC1 is fed to the H/E2 through the pump. The bottom product of DC1 is further fed to the H/E1 and to the outlet of the H/E1 that has 0.99999 water. From the H/E2, the material is fed into the distillation column2 (DC2) and the top product of DC2 is fed into DC1 with 274.82 kmol/h. The bottom product of DC2 is fed into the H/E2 and the outlet of H/E2, which has 0.09999 THF.

2.48 TEALARC LNG Refrigeration Cycle for Natural Gas

Author: Pragneshsinh J Sindha

Institution: Pacific School of Engineering, Surat

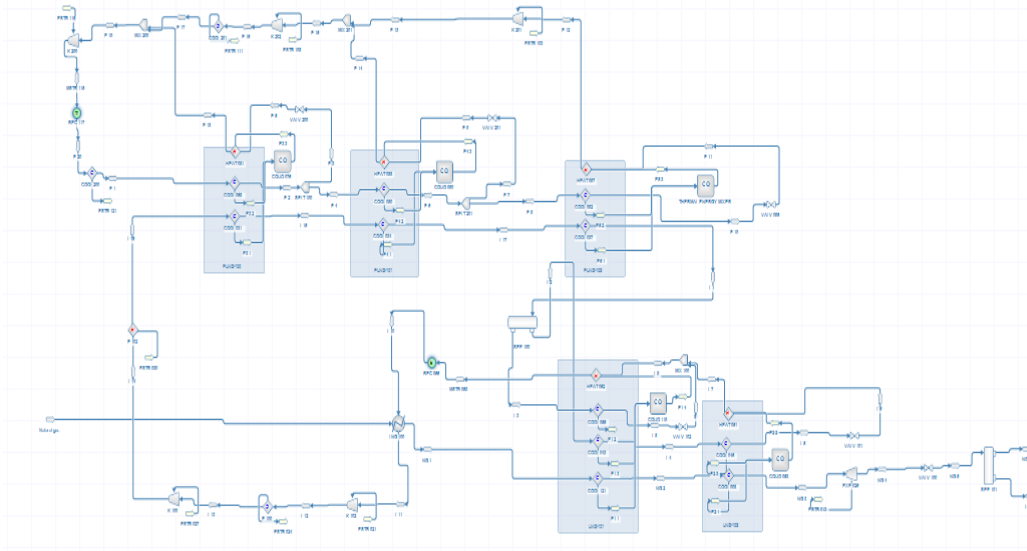

Herein, process simulation is carried out for the TEALARC LNG Plant, in which liquefied natural gas (LNG) is produced. The LNG is produced by the use of the refrigeration cycle, which is made up of four major components: compressor, evaporator, expansion valve and condenser. Basically, the refrigeration system removes energy from a low-temperature region and transfers heat to a high-temperature region. Mainly, there are two types of refrigeration cycles; here we have considered the vapor compression cycle.

In the TEALARC LNG plant there are two sections to be considered:

- Pre-cooling cycle
- Liquefaction cycle

Pre-cooling cycle: This cycle primarily consists of propane and ethane gas, which is cooled from a temperature of about 86°C to -64°C at a five pressure level. This cooling is achieved by the use of a cooler and energy is recycled by the use of the thermal energy mixer, which can provide further energy to the heater for heating purposes. Herein, the flow-sheet is noted with PLNG100, PLNG101, and PLNG102. The adiabatic compressor is used to compress the vapor to about 2260 KPa at three pressure level. The compressed stream is further condensed and recycled back to the cooler to continue the circulation.

Liquefaction cycle: The liquefaction cooling cycle consists of two compressors and a gas-liquid separator. There is also a heating and cooling arrangement, which is controlled by the use of a thermal energy mixer which is noted as LNG100; LNG101; LNG102. In the separator, vapor and liquid fraction is split. In this process, treated natural gas is fed into a heat-exchanger, where, it is cooled from 30°C to about -52°C , while the second outlet stream of the exchanger is superheated from about -56°C to about -1.7°C . This stream is compressed by compressors (K102 and K101) and subsequently cooled and recycled to the pre-cooling plant. The natural gas feed is further sub-cooled in the cooler and partially liquefied. After that, it is further cooled and liquefied at a temperature of -157°C , which is around the boiling point temperature of methane gas. The pressure of the natural gas stream is further reduced to the atmospheric pressure with the help of the expander, thereby reducing the temperature to

about -163°C . Then, the liquefied natural gas is flashed. From the simulation, the following results are obtained:

URL: <https://dwsim.fossee.in/flowsheeting-project/dwsim-flowsheet-run/101>

2.49 BTX Divided Wall Column

Author: Keval J Bhuva

Institution: Pacific School of Engineering, Surat

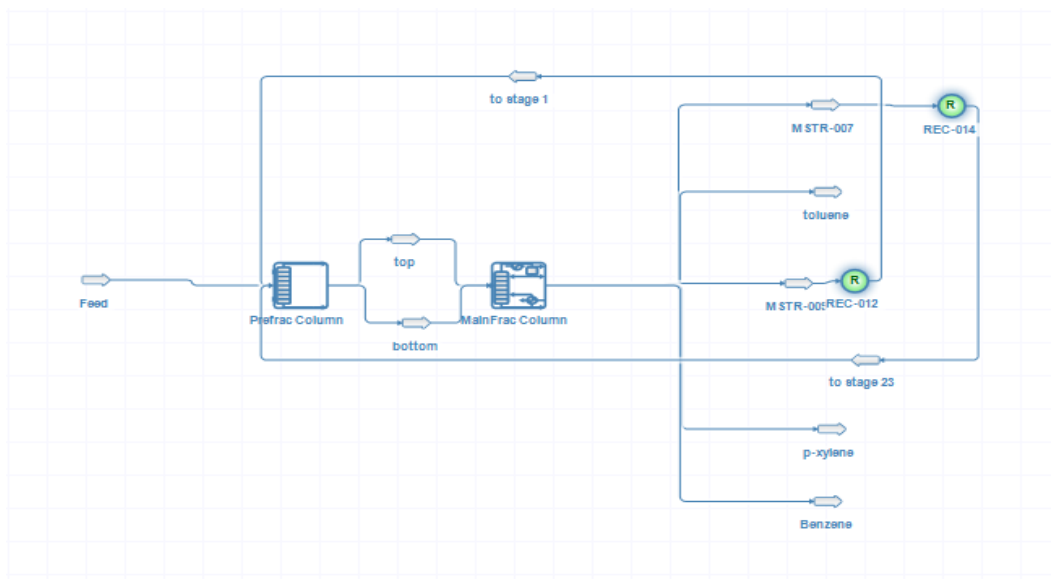

The divided-wall column is a practical way to implement the topology of the Petlyuk column that features two columns with interconnected vapor and liquid streams arising from a single reboiler and a single condenser. The dynamic control of the divided-wall column has been explored in relatively fewer papers. Control is more difficult, than with a conventional two-column separation sequence, because there is more interaction among the controlled and manipulated variables (since the four sections of the column are coupled).

The BTX involves the separation of benzene, toluene and p-xylene mixture to form the desired products. In the process, three side streams are produced. Here, raw material is fed to the prefrac column with 1 kmol/s, 358 K and 1atm pressure. The top product of the column is fed to the mainfrac column with 0.64140174 kmol/s, 141.08182 K temperature and 0.37000049 atm; the bottom product fed to the mainfrac column with 1.3116154 kmol/s, 357.6269 K temperature and 0.37000049 atm pressure. There are three side stream outlets from the mainfrac column, in which one of the side stream gave the final product of toluene with 0.296 kmol/s, 351.2307 K temperature and 0.37000049 atm. Two streams are further connected in the prefrac column. The top product of the mainfrac column is benzene, with 0.29779501 kmol/s, 323.25563 K temperature and 0.37000049 atm pressure. The bottom product (p-xylene) of the mainfrac column with 0.40416887 kmol/s, 377.64258 K temperature and pressure was 0.37000049 atm.

URL: <https://dwsim.fossee.in/flowsheeting-project/dwsim-flowsheet-run/105>

2.50 Energy Efficient Hybrid Separation Process for Acetic Acid Purification

Author: Abhinandan Nabera

Institution: National Institute of Technology, Tiruchirappalli

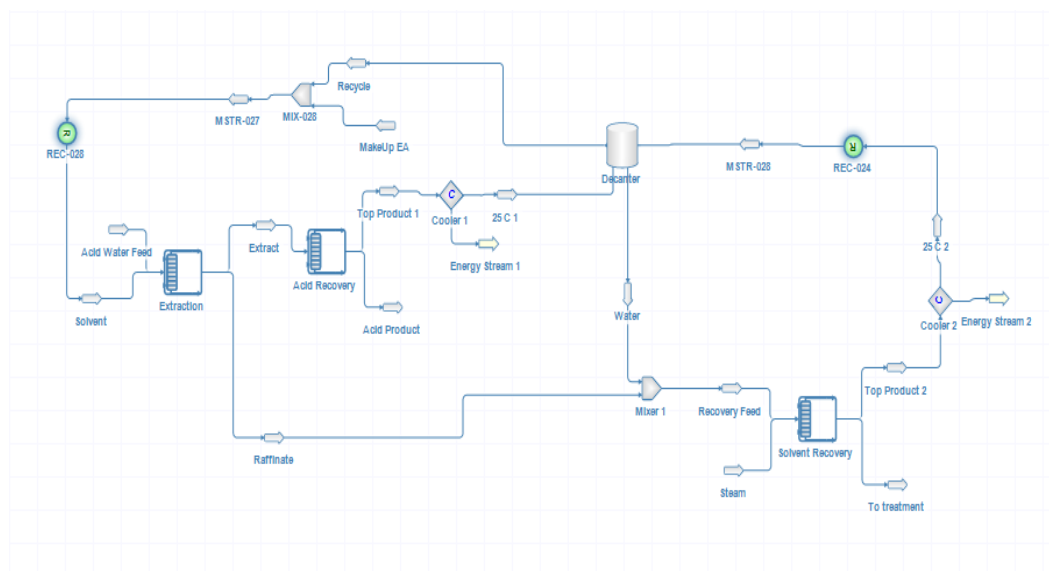

First, the acid water feed is fed into the extractive distillation column at a temperature of 298.15 K and 101325 Pa pressure. The solvent recycled from the decanter is also added to this column. At the end of this process, we have an extract and raffinate. The extract is sent to the acid recovery column to produce a top product and an acid product. The acid product is removed and the top product is cooled using a cooler to 298.15 K. This mixture is then sent to a decantation unit. The raffinate is sent to the mixer, where water from the decanter is mixed and it goes to the solvent recovery unit, in which steam is added at 373.15 K and 101325 Pa pressure. The top product is sent to a cooler, which, after cooling is sent to the decantation unit. Therefore, there are two feeds entering the decantation unit, both cooled to 298.15 K.

In this flow-sheet, the final product, pure acetic acid, which is produced by the methods of energy efficient hybrid separations of acetic acid and water, using ethyl acetate as a solvent. Hybrid separations utilize distillations, extraction, absorptions and other concepts. These methods increase the efficiency with reducing costs of production.

After Decantation takes place, the bottom product which is water, is sent to the mixer for further use in the solvent recovery unit and the top product is sent to a mixer where make up ethyl acetate is added. This mixture is recycled back to the first distillation column, and enters the distillation column with the acid water feed. The molar flow rate of acetic acid, ethyl acetate and water is shown in the table of results below. Therefore, high purity acetic acid is obtained by the hybrid separation processes which are energy efficient, considerably reducing costs.

URL: <https://dwsim.fossee.in/flowsheeting-project/dwsim-flowsheet-run/107>

2.51 Natural Gas Processing Simulation

Author: Course on Wheels (2017-2018)

Institution: Indian Institute of Technology Bombay

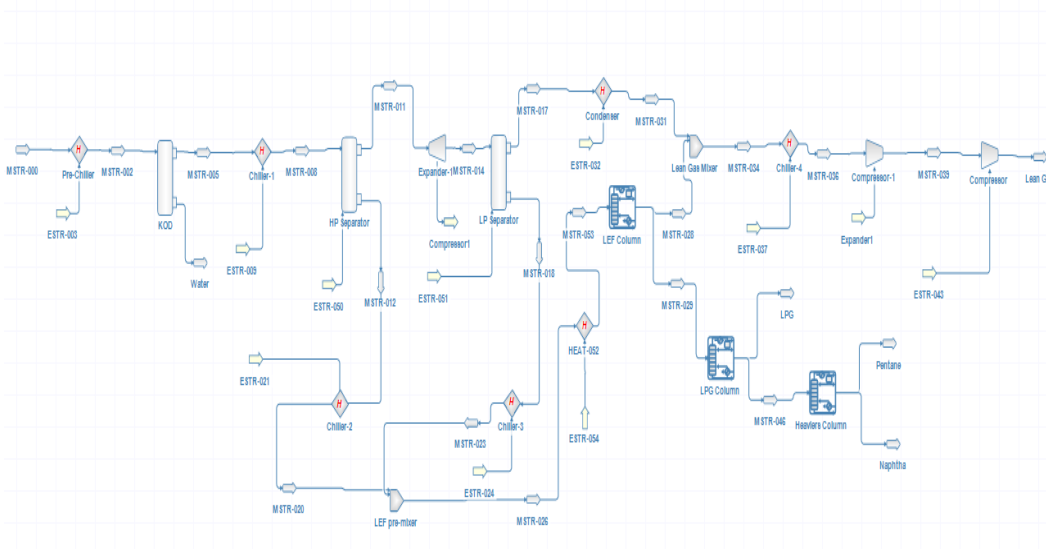

GAIL, Gandhar plant is one of the major plants of Gas Authority of India Ltd (GAIL). Natural gas being one of the most important raw materials containing light hydrocarbons with different uses has to be processed to get the desired light hydrocarbons for designated usage. In the Gandhar plant, Natural Gas supplied by ONGC is processed to get LPG, pentane and lean gas as output. The design capacity of the plant is 5.0 MMSCMD, though it is currently running at 4.2 MMSCMD due to a decreased supply of Natural Gas (due to its lesser availability currently). This plant is designed by Engineers India Ltd. (EIL). Many of the plants' equipments have been licensed by various licensing companies, including SOLAR Turbines Inc., Linde, ROTOFLOW, PSA Nitrogen Limited, while the Plant Control Interface Software was licensed by Honeywell automation. The cost of the project is Rs. 356 crores, generating sales of 82 lakhs per day from LPG, 30 lakhs per day from Naphtha and 3.5 lakhs per day from Pentane, leading to a consolidated turnover of 3332 lakhs per month. The expenditures amount to 2323 lakhs per month. Thus, GAIL earns a net profit of around 900 lakhs PM.

The plant design, made of equipments that come from different licensors and currently handles such large volumes of natural gas input, makes the simulation necessary to look for various areas of improvement possible. One of the major regions of concern before building such a plant on a large scale is whether the plant will work in the given conditions of equipment working, as well as of the raw material. This can first be investigated theoretically by simulations, to verify the validity of the process flow-sheet. Another important motivation behind this project was aimed towards analyzing the usage of Open Source process simulation software DWSIM, as compared to a normal licensed software like ASPEN, which is one of the most preferred softwares for such applications in the industry. The software licensing costs are quite high and using the open source software could considerably decrease these expenses which are significant towards developing chemical plants. To comprehend the level of reliability and versatility of open source softwares, one good way would be to simulate existing plants that demonstrate the same, using them. Thus, the need for improvement for getting better profits as well as to analyze and comprehend the robustness of the open source software DWSIM makes the project a good thing to work upon.

All the data pertaining to the process were input at the required place. The following assumptions were taken:

- The input raw material has zero water vapors. This was assumed to remove the dryer as a component in the flow-sheet, as water would not affect any process ahead and adding a complex component like dryer is difficult in DWSIM.
- The heat integration and energy integration implemented in the chiller as well as the compressor-expander system was not done, as the efficiency of its working was not known. Since, the parameters of input and output streams of these sections were known, we were able to take the streams ahead for further processing in the software.

- 4 Chiller streams are provided as per need, but separately and not in one common unit for the purpose of simplicity.

The product specifications are close to the ones the plant gives as an output. The irregularities in the data are due to unaccounted inefficiencies of the various components. The most important product, LPG has primarily C_3 , C_4 in its stream as was expected in the complete process. The successful and quite accurate simulation of the complete project implies that the open source software DWSIM could be a reliable software for the simulations of plants like the Natural Gas Processing unit at GAIL, Gandhar. The software has a diverse nature that simulates complex separation processes. Though the robustness of it, in case of the inclusion of chemical reactions in the process, is yet to be explored. The existing simulation can now further be used to try out various iterations to optimize the output flows as per theory results. Thus, this works as a miniature safe version of the complete plant to try out, before one actually tries some variations in the real plant, which could cost millions if the results go wrong.

URL: <https://dwsim.fossee.in/flowsheeting-project/dwsim-flowsheet-run/122>

2.52 Industrial Production of Acetone by Dehydrogenation of Isopropanol.

Author: Indranil Banerjee

Institution: MVJ College of Engineering

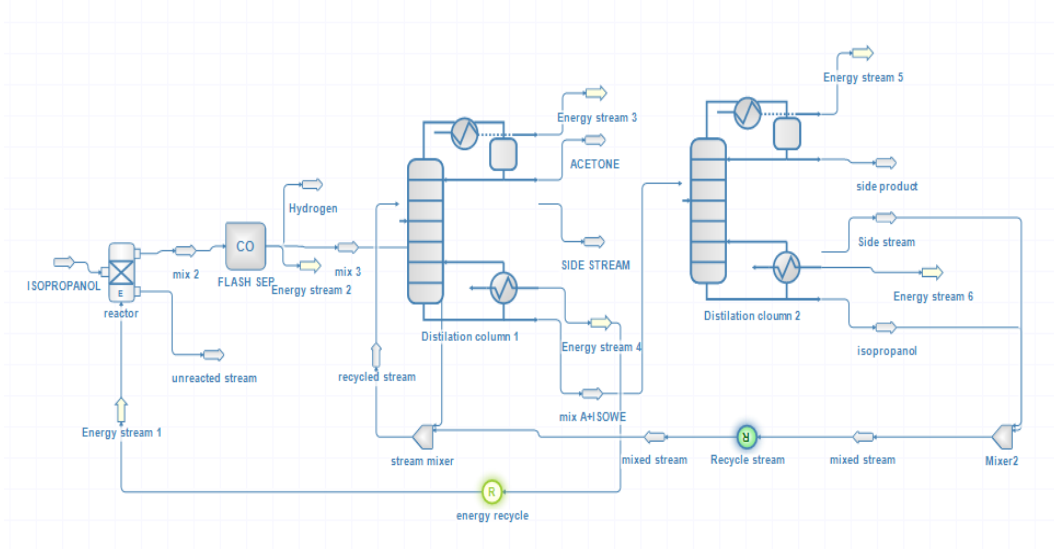

Acetone is one of the most important industrial solvents being used in industries since a long time. A lot of interest is being generated towards acetone derived chemicals. It is widely used as a volatile compound in paints and varnishes. The global requirement of acetone in India is estimated to be 55000 tons annually. It was initially prepared by dry distillation of metal acetates, but recently a number of methods have been devolved including biosynthesis, cumene process etc. One of the most economical processes by which it is prepared is the dehydrogenation of isopropanol, followed by fractionation.

The process starts with a pure stream of isopropanol being introduced into an equilibrium reactor, where a temperature of 530 K and a pressure drop of 10 bars is maintained. On this account, an endothermic reaction takes place and heat is absorbed during the process. The top product of the reactor is given to a flash separator, where a pressure drop of 2000 pa is maintained and hydrogen is separated as a lighter product at the top and a mixture of isopropanol and acetone is taken as the bottom product

.This product is then mixed with the stream from the end process and is fed to a 12 stage distillation tower, where a pressure of 1 atm and a reflux ratio of 1.5 is maintained. The top product contains pure acetone (that is 99% pure) and the side stream and the bottom product contain a mixture of isopropanol and traces of acetone. These are again given to a distillation column, where the same conditions are maintained. The bottoms and the side stream of this column contain isopropanol, which is recycled back and mixed with the feed of the distillation column. In this process, 99% of acetone is produced with most of the unreacted isopropanol being recycled, and the energy is recycled wherever feasible.

URL: <https://dwsim.fossee.in/flowsheeting-project/dwsim-flowsheet-run/67>

2.53 Pressure Swing Distillation of Isobutanol and N-Heptane

Author: Pragneshsinh Sindha

Institution: Pacific School of Engineering

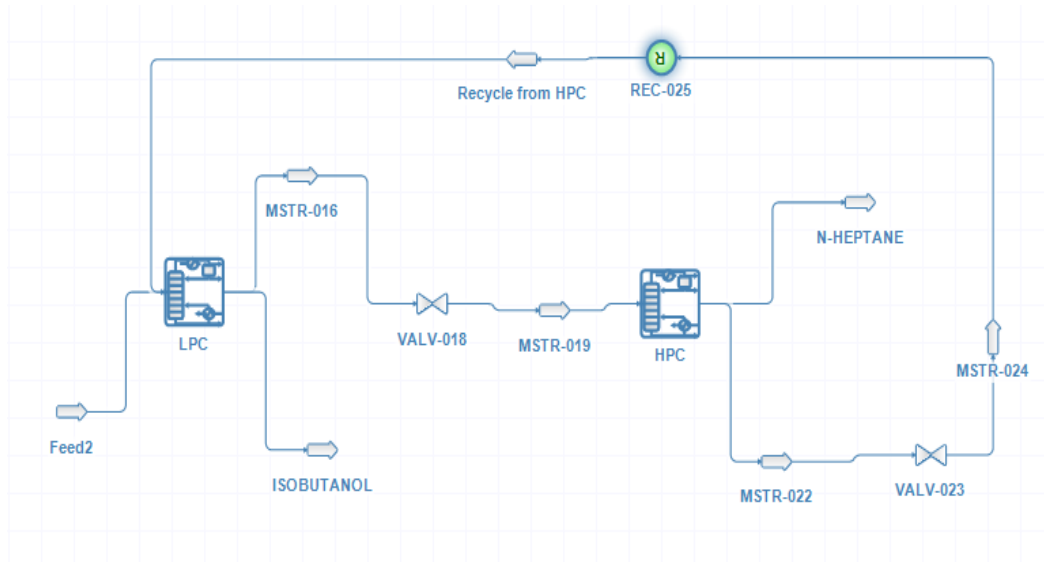

Here, simulation is carried out for the separation of isobutanol and N-heptane, which is generated during the production of triisobutyl vanadate. This mixture is separated for the reuse of the reactants, to reduce the cost of raw material. For the separation of this mixture, special distillation techniques like azeotropic distillation, Extractive distillation, Pressure Swing distillation etc. may be used. But amongst this, pressure swing distillation (PSD) has received research attention because of its advantages like simple configuration, possibility of heat integration and majorly the fact that it does not require a third component (as used in azeotropic distillation). Pressure Swing Distillation is commonly used for azeotrope separation, in which based on the changing pressure, the separation is made easier. As the pressure is changed, the composition of the mixture also changes, which then forms a minimum or maximum azeotrope. In the case of isobutanol, if the pressure is increased, the minimum azeotrope will move to the maximum azeotrope .

Here two flow-sheets are simulated for the separation of isobutanol and N-heptane. For simulation, data is obtained from Yinglong Wang's works .Two flow-sheets are simulated- One for the conventional pressure swing distillation, and the second for the unusual pressure swing distillation. Both are the same, except in the unusual pressure swing distillation, where one of the products is carried out from top of the column, while in the conventional pressure swing distillation, all the products withdrawn from the bottom of columns. In both flow-sheets, the feed contains 0.2 mol N-heptane and 0.8 mol isobutanol. However, the recycled stream has different proportions of mol fractions and molar flow of

both components. For getting results that are nearer to literature, here the NRTL method is used and the coefficient data is fitted.

URL: <https://dwsim.fossee.in/flowsheeting-project/dwsim-flowsheet-run/113>

2.54 Maleic Anhydride Production from Benzene

Author: Sanchit Badodekar

Institution: Visvesvaraya National Institute of Technology

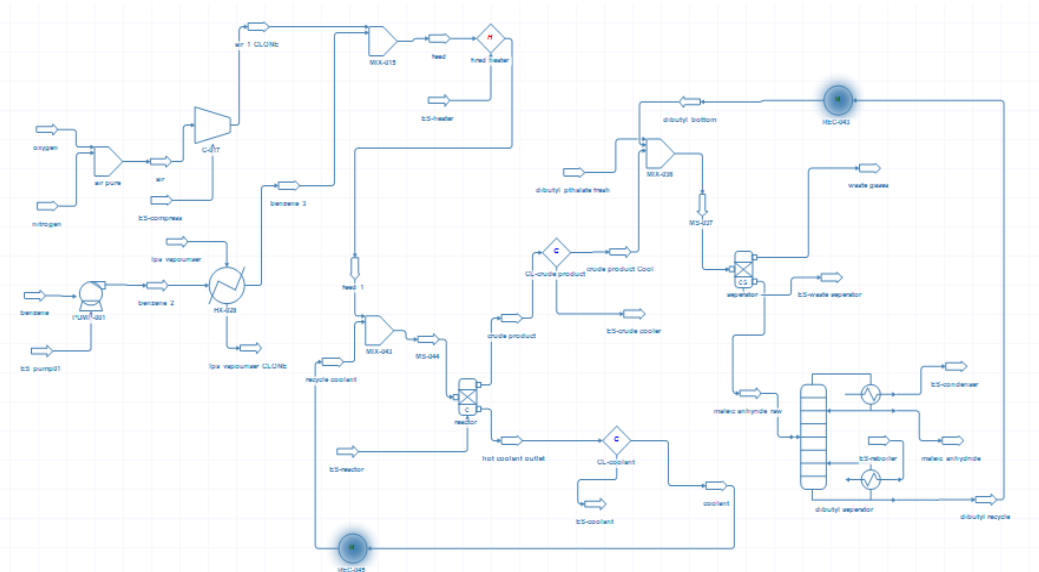

Maleic anhydride is an important raw material used to manufacture phthalic type alkyd and polyester resins, surface coatings, lubricant additives, plasticizers (qv), copolymers (qv), and agricultural chemicals. Asia-Pacific is the largest as well as the fastest-growing market for maleic anhydride, whereas North America and Europe are the second and the third largest markets respectively. Rapid growth in the end use industries, the improved standard of living, and strong foothold of the major market players are the key factors that drive the growth of the maleic anhydride market in Asia-Pacific.

On an inert support, benzene is vaporised in the heat exchanger E601 and then mixed with compressed air. The mixture is sent to a fired heater to heat the feed to the desired temperature inlet conditions. The reaction is highly exothermic and hence the ratio of air to benzene in the feed mixture is kept high. A conversion reactor is used to convert benzene into maleic anhydride and combustion products. The unreacted benzene, maleic anhydride and combustion products are cooled and sent to an absorption tower (compound separator) for the separation of combustion gases. The product, an organic solvent (dibutyl phthalate), is used to absorb maleic anhydride into it. The down product is sent to the separation tower to further separate maleic anhydride and dibutyl phthalate. Crude maleic anhydride is sent further for purification, dibutyl phthalate is recycled back to the absorption tower with the make-up stream to balance losses. The Peng-Robinson thermodynamics model is employed in this flow-sheet.

URL: <https://dwsim.fossee.in/flowsheeting-project/dwsim-flowsheet-run/83>

2.55 Design of an industrial 1,4- Dioxane Dehydration process with light feed impurity

Author: A.S. Rahul

Institution: SASTRA Deemed University, Thanjavur

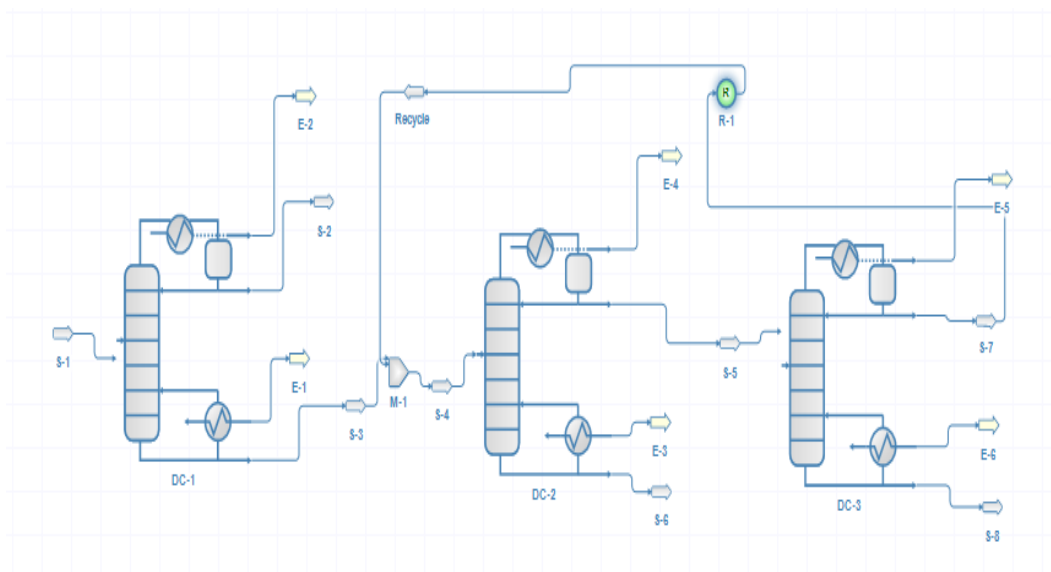

The process involves a feed stream (S-1) comprising of aqueous 1,4-Dioxane and water with small amounts of light impurity Tri-Ethylamine (TEA), fed to a pre-concentrator column in order to remove the impure TEA. The bottom product of DC-1 (S-3) is recycled along with the distillate stream (S-7) of DC-3 and feed to DC-2. Thus, with a low-pressure column (DC-2) operating at 1 atm and a high-pressure column operating at 8 atm (DC-3), 1,4-Dioxane and water can be separated using a two column sequence. Streams S-6 and S-8 are rich in water and 1,4 -Dioxane respectively.

A rigorous column (DC-1) was simulated for the separation of Tri-Ethylamine with a number of stages set to 7, and a bottoms rate of 1177.16 kg/h. Two rigorous columns (DC-2 and DC-3) were implemented to separate 1,4-Dioxane and water.

URL: <https://dwsim.fossee.in/flowsheeting-project/dwsim-flowsheet-run/150>

2.56 Production of Ethylene Glycol by Non-Catalytic Liquid Phase Hydration of Ethylene Oxide

Author: Tamtam Sreeram

Institution: Bapatla Engineering College

Ethylene glycol is a chemical commonly used in many commercial and industrial applications, including antifreeze and coolants. Each mol of ethylene oxide reacts with a mol of water to give rise to one mol of ethylene Glycol. But the product formed, ethylene glycol, reacts with ethylene oxide to give rise to diethyleneglycol.

In order to increase the yield of ethylene glycol, 20 mols of water is fed to the reactor for each mol of ethylene glycol entering. However, a maximum of around 90 % yield of ethylene glycol is obtained only by non-catalytic reactions/ processes. The ethylene oxide limiting reactant and undergoes a complete conversion in the plug-flow reactor. Therefore, the reaction mixture consists of large amounts of water, which is mostly removed by employing multiple effect feed forward evaporators. The pressure decreases in the forward direction. Water is mostly removed in the multi-stage plate distillation column. The ethylene glycol is finally removed in the next distillation column, which is also a multi-stage plate column.

URL: <https://dwsim.fossee.in/flowsheeting-project/dwsim-flowsheet-run/64>

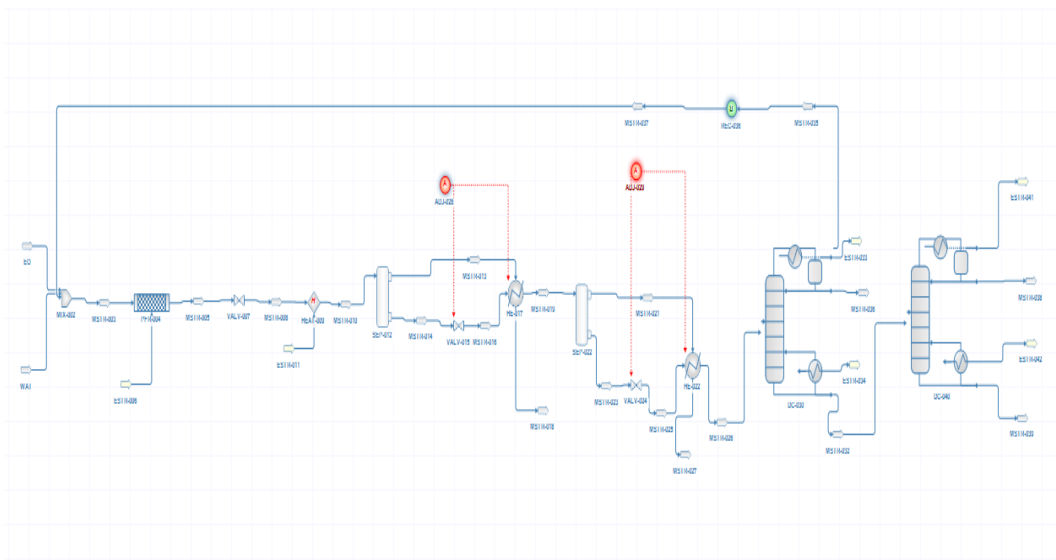

2.57 Pressure Swing Distillation of Acetonitrile-Water System

Author: Nikhil Sharma

Institution: Aditya Silver Oak Institute of Technology, Ahmedabad

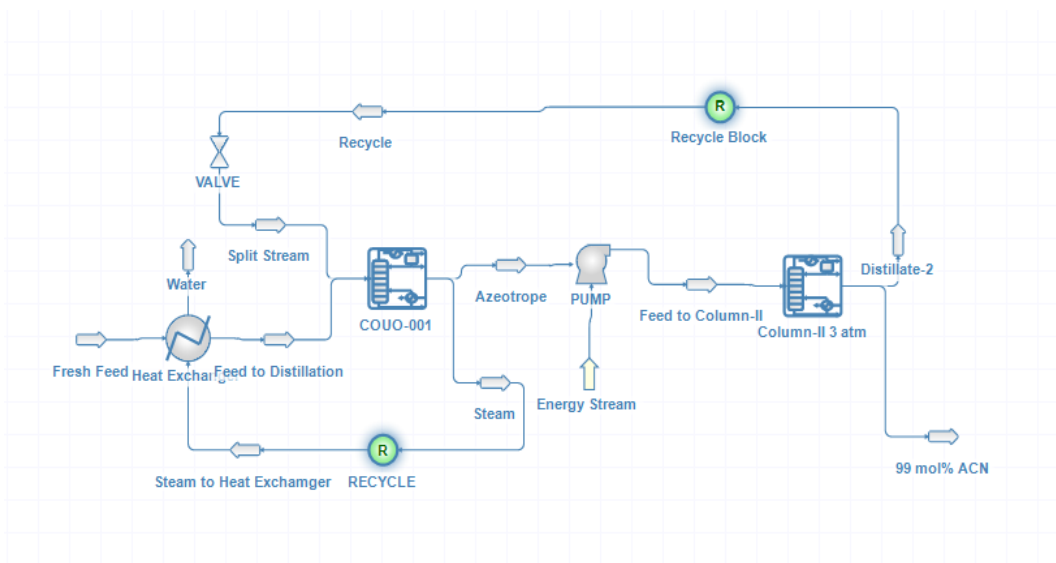

Acetonitrile forms a minimum boiling azeotrope with water at 101.325 kPa at 350.15 K. An aqueous stream containing 50% mass is to be separated by the pressure swing distillation technique.

In column-I, fresh feed with a recycled stream (i.e., distillate from column-II) CAN, is distilled at 101.325 kPa in the form of an azeotrope, while the bottom product is water with a negligible impurity of ACN. The azeotrope from the top of column-I is fed to column-II, which is operated at 3 atm. The top product from column-II is again an azeotrope. The bottom product from column-II is 99% Acetonitrile (ACN).

URL: <https://dwsim.fossee.in/flowsheeting-project/dwsim-flowsheet-run/151>

2.58 Separation of Methyl Methacrylate, Methanol and Water

Author: Nikhil Sharma

Institution: Aditya Silver Oak Institute of Technology, Ahmedabad

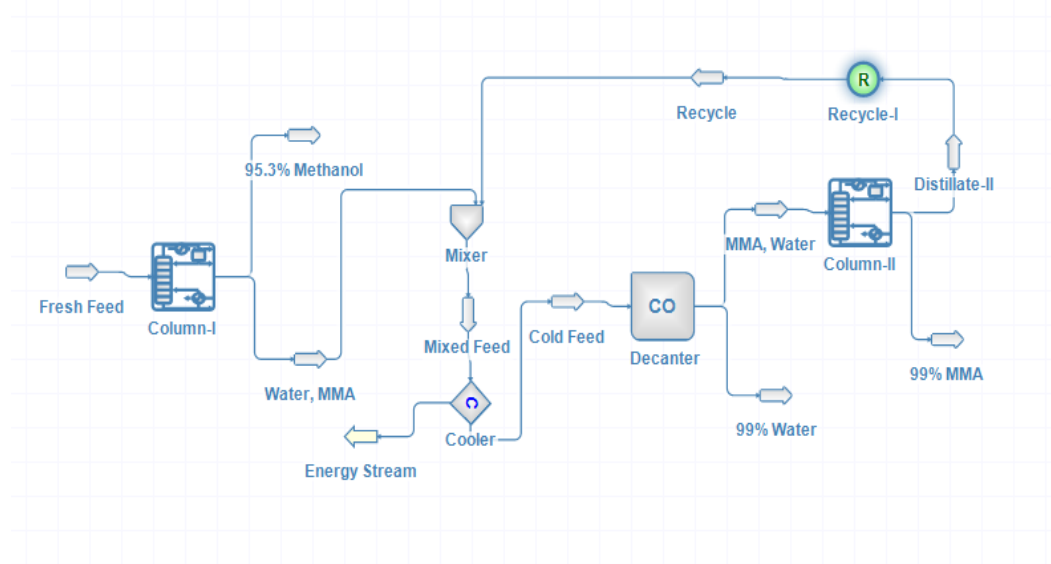

Azeotropes are close boiling mixtures which are difficult to separate through the process of simple distillation. To separate azeotropic mixtures, another light component is added to the mixture through which a binary minimum boiling azeotrope can be formed. The bottom is generally obtained as a high purity product and the top product is near to a heterogeneous azeotrope. This top product can be sent to decanter for separation in aqueous and organic streams. The organic phase is sent back to the column, whereas the aqueous stream is processed as per requirement.

The flow-sheet is shown in Figure. The bottom composition of the distillation column was designed to be near the MMA/H_2O azeotrope, so that a decanter can be designed to obtain aqueous and organic streams. The system is shown, which contains two columns and one recycle stream. The top product from column-I is 95.3% Methanol and the bottom product is mixed with the recycle from column-II and is sent to decanter at 323.15 K. The bottom product from the decanter is 99% water and the top product is again sent to the column for further separation. The bottom product of column-II is 99% MMA, while the top product is recycled and sent back.

URL: <https://dwsim.fossee.in/flowsheeting-project/dwsim-flowsheet-run/159>

2.59 Methanol-Water Separation using Neat Operation

Author: Nikhil Sharma

Institution: Aditya Silver Oak Institute of Technology, Ahmedabad

Neat operation means that the condenser duty required in one column is exactly equal to the reboiler duty in the next column. Here, the system used is methanol-water. Methanol is more volatile, so it is obtained as a distillate in both the units with a purity of around 99%. The water is obtained from the bottoms in each column, which is around 99% pure. The feed composition is 60 mol % methanol and 40mol % water flowing at a rate of 1 kmol/s. The feed is split in the ratio of 0.5086 kmol/s and 0.4914 kmol/s, so that the column operates in a “neat” manner. The low pressure column-I operates at 0.6 atm and column-II operates at 5 atm. The reflux ratio in column-II is 2, so that heat duty of condenser-I and reboiler-II are same.

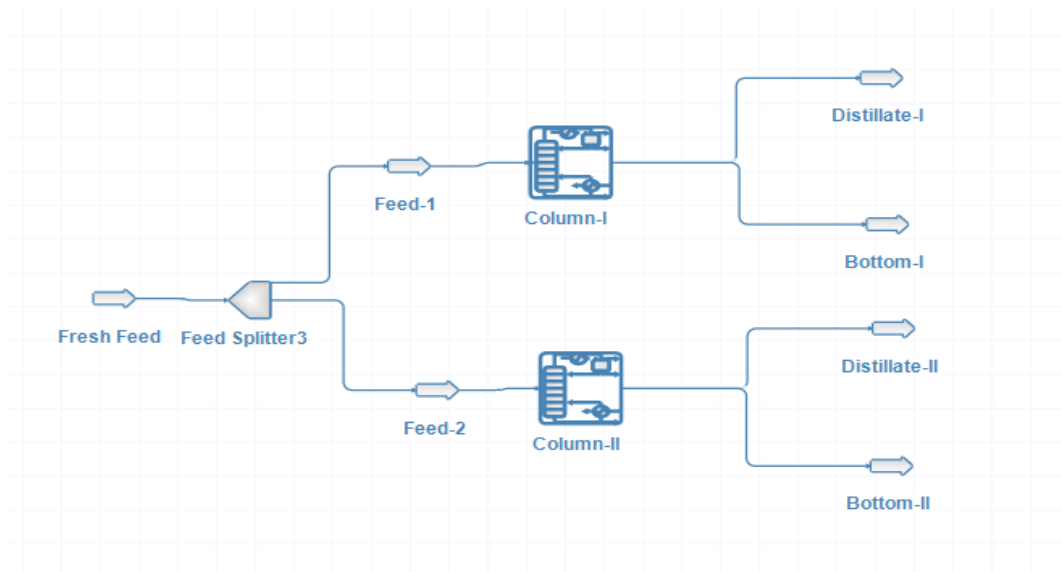

The component purity of each stream is around 99 %. The condenser duty in Column-I is the same as the reboiler duty in Column-II, that is 33188 kW. By this operation, the total capital investment and energy consumption is reduced.

URL: <https://dwsim.fossee.in/flowsheeting-project/dwsim-flowsheet-run/155>

2.60 Production of Acetic Acid using Acetaldehyde

Author: Sajal Kumar and Tanya Shrivastava

Institution: National Institute of Technology Warangal

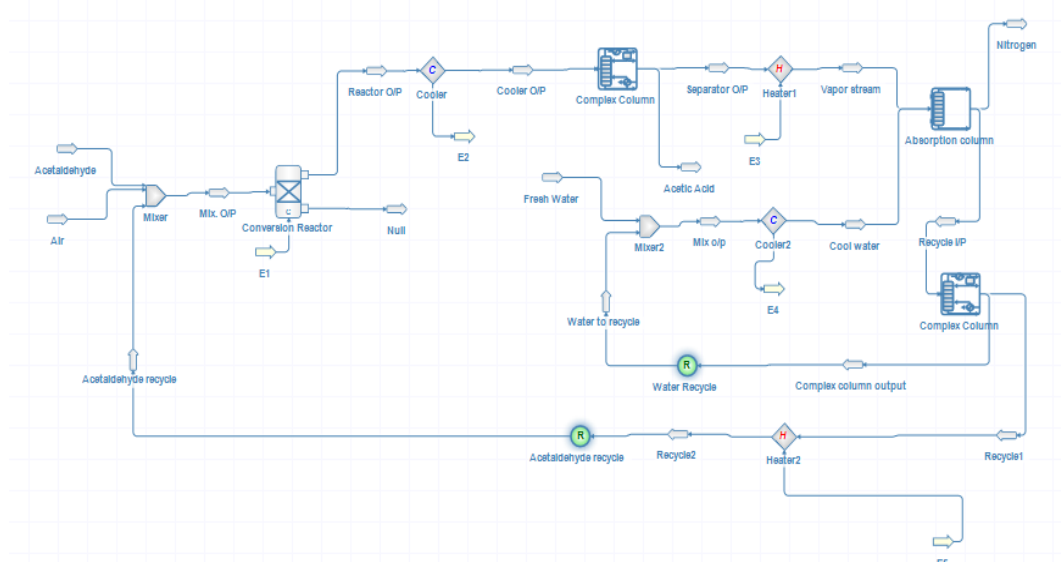

Acetic acid is the second, simplest carboxylic acid (after formic acid). It consists of a methyl group attached to a carboxyl group. It is an important chemical reagent and industrial chemical, used primarily in the production of cellulose acetate for photographic film, polyvinyl acetate for wood glue, and synthetic fibres and fabrics. In households, diluted acetic acid is often used in de-scaling agents.

This flow-sheet is used for the production of acetic acid by the oxidation of acetaldehyde. It consists of a mixer to mix the recycle stream with the feed streams, conversion reactor, a cooler to cool the products, a complex column to separate the product (acetic acid) and unreacted feed, followed by an absorption column to separate nitrogen from unreacted feed, using water as an absorbent. A complex column is used to separate water from the recycle stream.

The products from the reactor are sent to the cooler unit, where the products are cooled. Then, acetic acid is separated from the unreacted acetaldehyde and the air component, using a complex column based on the volatility of the compounds. The product, acetic acid, is obtained from the bottom stream of the complex column. The unreacted stream obtained from the complex column is sent to a heater to vaporize for better absorption of acetaldehyde in the absorption column, to separate nitrogen gas from the unreacted part and to minimise the nitrogen content in the recycle stream. Water is used as an absorbent, which is separated using a complex column from unreacted acetaldehyde and recycled back. Some make-up water is added to the recycle stream and cooled using a cooler, for better absorption of the acetaldehyde. The top product form the complex column is heated to make the top effluent at room temperature. The stream, containing acetaldehyde and oxygen, is sent to the mixer through a recycle block to increase the overall yield.

URL: <https://dwsim.fossee.in/flowsheeting-project/dwsim-flowsheet-run/121>

2.61 Extractive Distillation for Dehydration of Tetrahydrofuran

Author: Nikhil Sharma

Institution: Aditya Silver Oak Institute of Technology, Ahmedabad

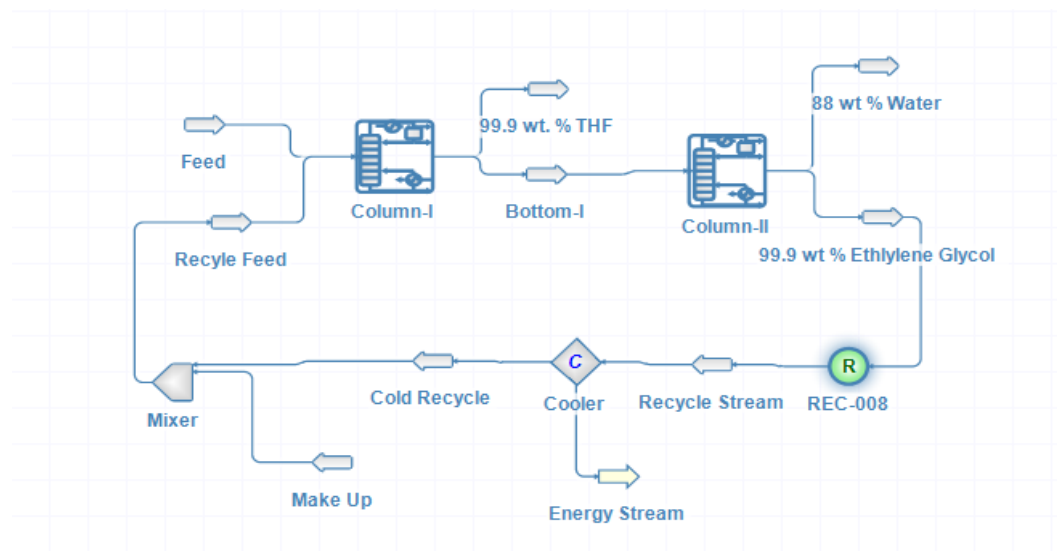

Tetrahydrofuran is an important organic raw material. The demand for high purity tetrahydrofuran is rapidly increasing, as it can be used as a reaction solvent, an adhesive etc. But it is commercially beneficial only when it is available in high purity i.e. 99.9% wt. basis. At atmospheric pressure, tetrahydrofuran gets easily dissolved in water and forms a minimum boiling homogeneous azeotrope. Therefore, it is not possible to separate the tetrahydrofuran-water solution completely by simple distillation.

Among the various entrainers available like DMSO, DMF, ethylene glycol is used here, as it is cheap and easily available. Column-I is extractive column and column-II is for the recovery of the entrainer ethylene glycol. The azeotropic mixture of tetrahydrofuran-water along with the entrainer is fed to column-I. The top product of column-I is our desired product i.e. 99.9 wt. % tetrahydrofuran. The bottom product is fed to column-II for entrainer recovery, where ethylene glycol is separated from water

and separated ethylene glycol is then obtained from the bottom with 99.9 wt. % purity. This entrainer is again recycled to column-I after cooling and adding a make-up stream of entrainer to account for the loss of entrainer in the distillates of column-I and column-II. The fresh feed flow rate is kept at 3000 kg/hr containing 0.9 wt. % tetrahydrofuran and water at a temperature of 320 K. The pressure of both the columns are maintained at 1.1 atm. Distillate from column-I is our desired product i.e. tetrahydrofuran with 99.9 wt. % purity.

URL: <https://dwsim.fossee.in/flowsheeting-project/dwsim-flowsheet-run/160>

2.62 Production of Monoethanolamine, Diethanolamine, Triethanolamine

Author: Sajal Kumar

Institution: National Institute of Technology Warangal

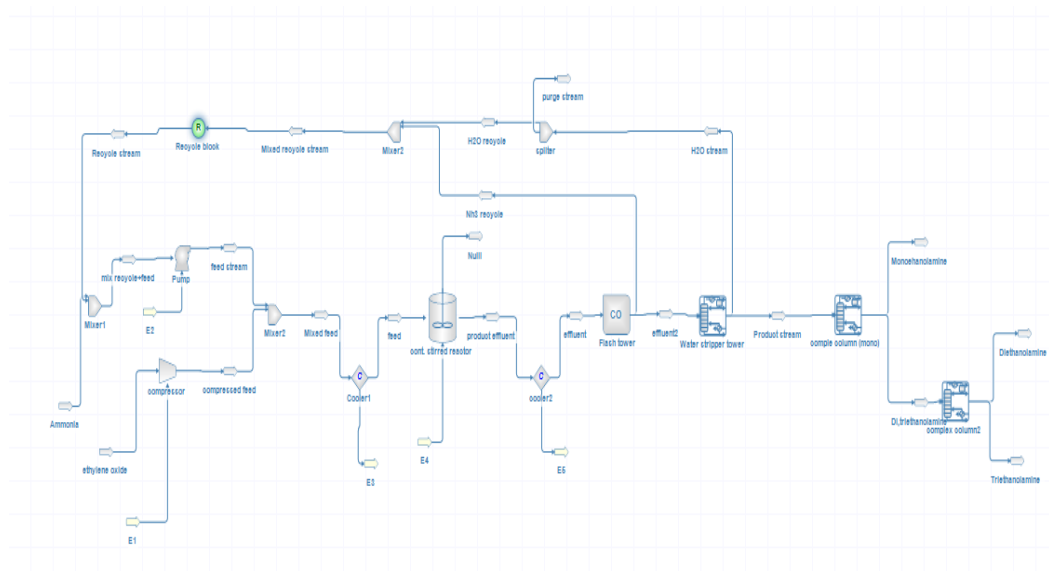

This flow-sheet is used for the production of derivatives of alcohol amine, which consists of a mixer to mix the recycle stream with the feed streams, compressor and pump to pressurize the feed stream. It consists of a continuous stirred tank reactor and coolers for a decrease in the temperature and a flash tower to separate ammonia from the product stream. It also contains a water stripper to separate water, and a series of complex columns to separate the main products from each other. A stream splitter is used to remove a purge stream to avoid the accumulation of water, and a recycle block is used to recycle the unconverted ammonia and ethylene oxide.

Aqueous ammonia is pumped with the recycle stream, and ethylene oxide is compressed in a compressor. Both are mixed in a mixer and then sent to a continuous stirred tank reactor. The product stream from the reactor is cooled and flashed in a flash tower to remove unconverted ammonia with product stream. The effluent is sent to a water stripper to separate water. The product stream is passed through a series of complex columns to separate the main products. Monoethanolamine is obtained from the top of first complex column and the bottom is sent to the second complex column. Diethanolamine is obtained as a top effluent and triethanolamine is obtained as the bottom stream. If it contains further impurities, then the bottom of the second column is sent to the third column to separate triethanolamine as a top effluent and the heavy end at the bottom. The stream from the water stripper is sent through a stream splitter to remove some water as in the purge stream. Another stream is mixed with recycled ammonia from the flash tower and recycled back using a recycle block.

2.63 Turton Design for Production of Acetone

Author: Boddupally Manoj Kumar and Bheemesh Karri

Institution: National Institute of Technology Warangal

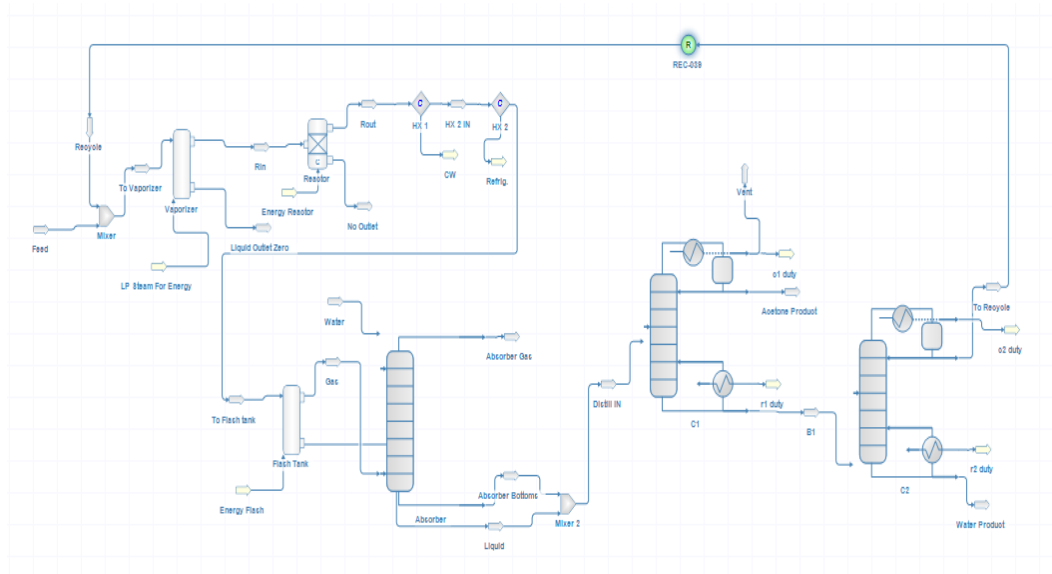

Acetone is a colourless, volatile, flammable liquid, and is the simplest and smallest ketone. The production of acetone involves the dehydrogenation of IPA in a high-temperature gas-phase reactor. Turton et al assumed the reaction to be irreversible and specified that the per-pass conversion of IPA is 90% to prevent side reactions. The reaction occurs in the vapor phase in the presence of a solid catalyst.

Using the reactor size and kinetics given in Turton et al gave 90% of the conversion specified by the authors, if the presence of the solid catalyst was neglected. Of course, the catalyst is present, so a bigger reactor would have to be used to give the same conversion. The kinetics used by Turton et al is also unrealistic. The reaction cannot be irreversible. If it were irreversible, we could operate at a high pressure, which would raise the concentration of IPA and drive the reaction towards the products. But LeChatier's principle tells us that raising the pressure should drive the reaction toward the reactant, since there are two mols of product generated from one mol of reactant. In an attempt to modify the kinetics so as to capture these realistic effects, an RGIBBS reactor was run in Aspen Plus to find the effect of pressure on conversion. At 623 K (the temperature in the Turton flowsheet), the RGIBBS equilibrium conversion is 97.1% at 2 atm. This should be compared with the 90% conversion in the Turton design. As the pressures are raised to 5 atm, 10 atm, and 15 atm, the equilibrium conversions decrease to 93.3%, 87.8%, and 83.2%. Clearly, the effect of pressure must be considered. The kinetics was modified to assume a reversible reaction.

The activation energy of the forward reaction used, is the value given in Turton et al (72 380 kJ/kmol). The activation energy of the reverse reaction was calculated using the heat of the reaction (+62 900 kJ/kmol). To be consistent with the assumption made by Turton, the conversion in the reactor is held at 90% as the other design parameters are changed.

2.64 Production of Diethyl Ether from Ethanol

Author: K Srujana and S V Karthik

Institution: National Institute of Technology Warangal

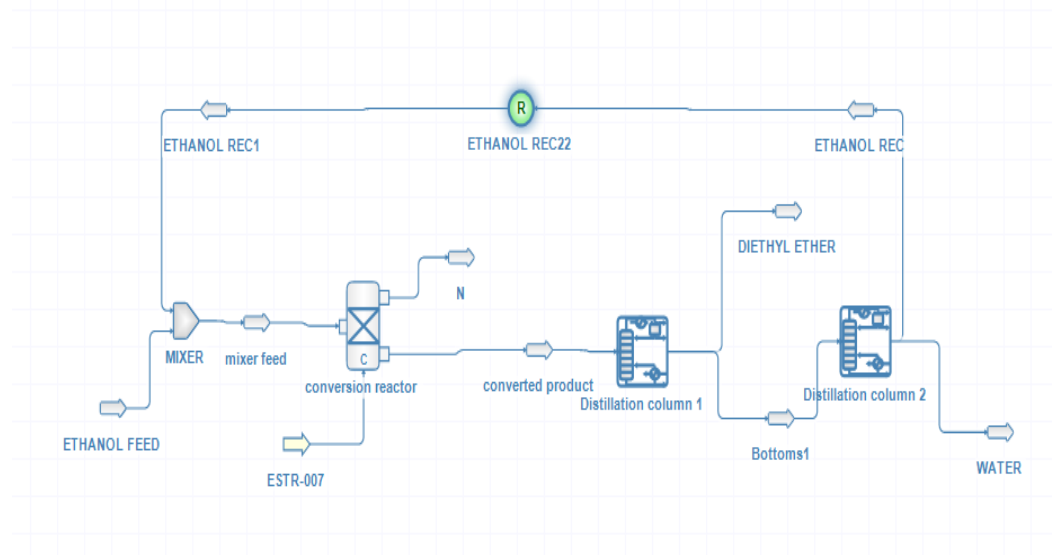

Diethyl ether ($C_2H_5)_2O$ is an organic compound which is also known as ethyl ether, ether or ethoxyethane. It is a colourless, highly volatile flammable liquid with a characteristic odour. It is commonly used as a solvent and as a general anesthetic. It has narcotic properties so it has been known to cause temporary psychological addiction, sometimes referred to as etheromania.

The flow-sheet for the diethyl ether production consists of a mixer to mix the recycle stream (ethanol) and ethanol feed stream, conversion reactor and two distillation columns. One distillation column is to purify diethyl ether and the latter is used for separating water and the recycle stream. About 50% conversion is obtained in the conversion reactor. The product from the mixer is sent to the conversion reactor, while the product from the reactor is sent to the distillation column 1 to separate pure diethyl ether and the mixed bottom, which is the feed for distillation column 2, where recycled ethanol stream and water are being separated. All the streams are at atmospheric pressure.

URL: <https://dwsim.fossee.in/flowsheeting-project/dwsim-flowsheet-run/167>

2.65 Production of Ethylene Oxide by Air Oxidation Process

Author: Doshi Varunkumar Rahulbhai

Institution: Shroff S. R. Rotary Institute of Chemical Technology (GTU)

Ethylene oxide production plant is the downstream plant of Gas Cracker. Ethylene oxide is widely used in the production of ethylene glycol. In US and also in India, ethylene oxide has its principle outlet in the production of ethylene glycol. It also used as other derivatives, like glycol polyesters, non-ionic detergents and ethanol-amines. This project depicts the actual plant production of ethylene oxide using ethylene and oxygen.

Ethylene from the Gas Cracker plant and oxygen from the Air Separation plant are sent to ethylene oxide (EO) plant. It is then compressed to 21.7 bar (2170 kPa) in the compressor to achieve reaction pressure. Then, the oxygen goes to the oxygen mixing station, where oxygen is carefully supplied. After that, the mixture goes to the Shell and Tube Reactor, where partial oxidation of Ethylene takes place in the presence of a silver (Alumina based) catalyst. Only 12% of Ethylene is converted to EO. Some

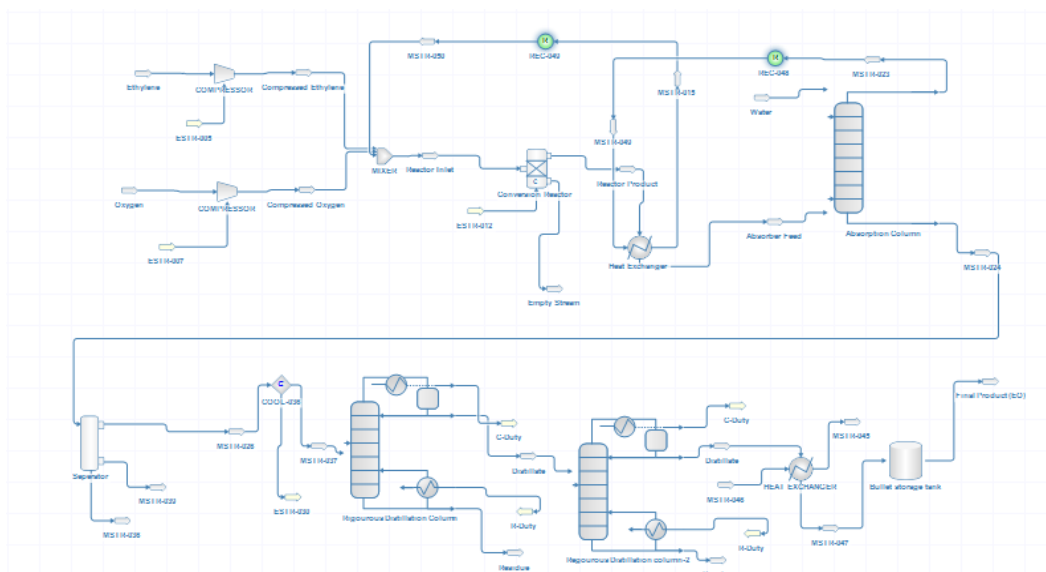

CO_2 is also produced during the reaction. After the reaction, EO, CO_2 and the unreacted feed go to the absorption column. In the absorption column, most of the EO is absorbed in the water and the lean EO stream goes to the heat-exchanger. The lean EO stream consists mainly of ethylene, oxygen and CO_2 . It will exchange heat with the reactor outlet stream. After exchanging heat, this stream will be recycled to the reactor feed stream. The absorption column bottom goes to the disorber, where some amount of water removed. The top of the column will go for further purification in the stripper and the distillation column. After purification, pure ethylene oxide gets it from the top and it send to the EO storage tank.

URL: <https://dwsim.fossee.in/flowsheeting-project/dwsim-flowsheet-run/153>

2.66 Steady State Simulation of Separation Column for Propylene-Propane Mixture

Author: Kiran Kumar V and Lovely Kuruvilla

Institution: B.M.S. College Of Engineering

Propylene is one of the most significant intermediate petrochemical products. The blend of propylene, propane, C-5 fraction, hexane, water, hydrogen, N₂ and some other constituents from a petrochemical plant are the raw materials. Due to the necessity of a high purity feed stream, propylene has to be separated from propane and the other impurities in the separation column. The simulation of the propane-propylene separation column was carried out using the DWSIM simulation engine, to determine the effect of the main operating parameters on the product composition. The process requires high capital cost and energy consumption. To maximize the profit as the energy prices rise, energy efficiency, along with optimizing the product quality and maximizing the high-value product yields, have become more important. Thus, a modification of propane/propylene separation process can highly affect the economics of the whole production system.

The Soave—Re dlich—Kwong which is an equation of state thermodynamic property model is selected for the simulation. The ternary feed mixture of Propane, Propylene and n-Pentane is fed into the mixer at a molar flow rate of 45.2385, 79.012 and 1.2599 mol/s respectively, temperature of 310.92 K, and pressure of 1999 kPa. The pump is employed to increase the pressure to 2137kPa. The feed then enters at the 70th stage of the stripping column (reboiled absorber) which has a total of 100 stages and is maintained at the top pressure of 1931 kPa and bottom pressure of 2068 kPa, with a pressure drop of 0.2 psia. Due to the high product purity and the low relative volatility, the number of stages required for separation is very high. The distillate has a mol fraction of 0.5295 Propylene and 0.4704 Propane which

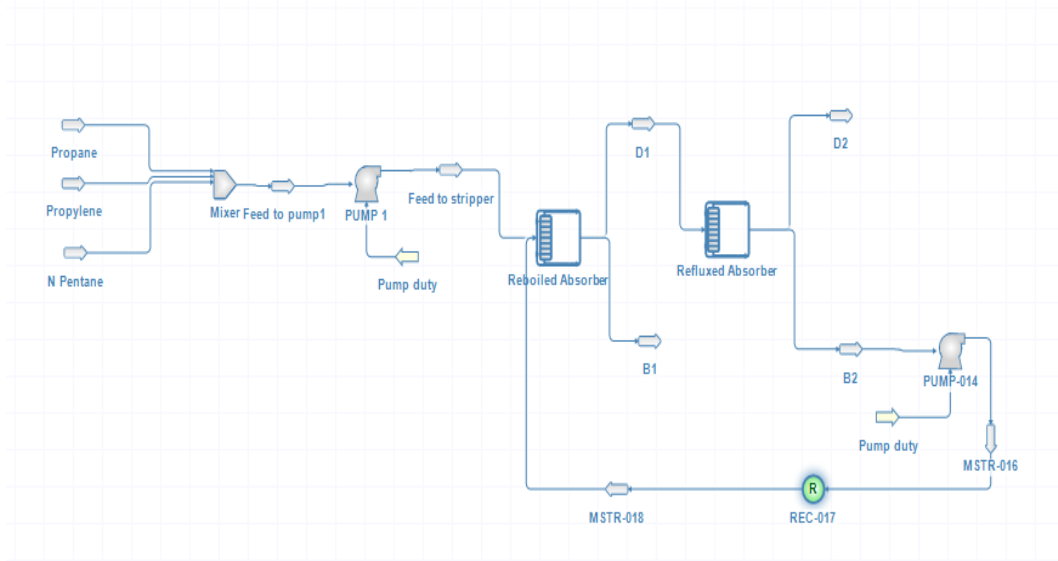

is further sent to the refluxed absorber of 120 stages. 0.9900 mol fraction of Propylene is distilled out. Also, the bottom stream with a mol fraction of 0.5039 Propylene and 0.4960 Propane is recycled back to the reboiled absorber. Thus, Propylene is separated from the feed mixture and 99% product purity is obtained.

URL: <https://dwsim.fossee.in/flowsheeting-project/dwsim-flowsheet-run/58>

2.67 Cooling of Benzene and Heating of Methane by Circulation of Water

Author: D Sasi Kiran and S V Karthik

Institution: National Institute of Technology Warangal

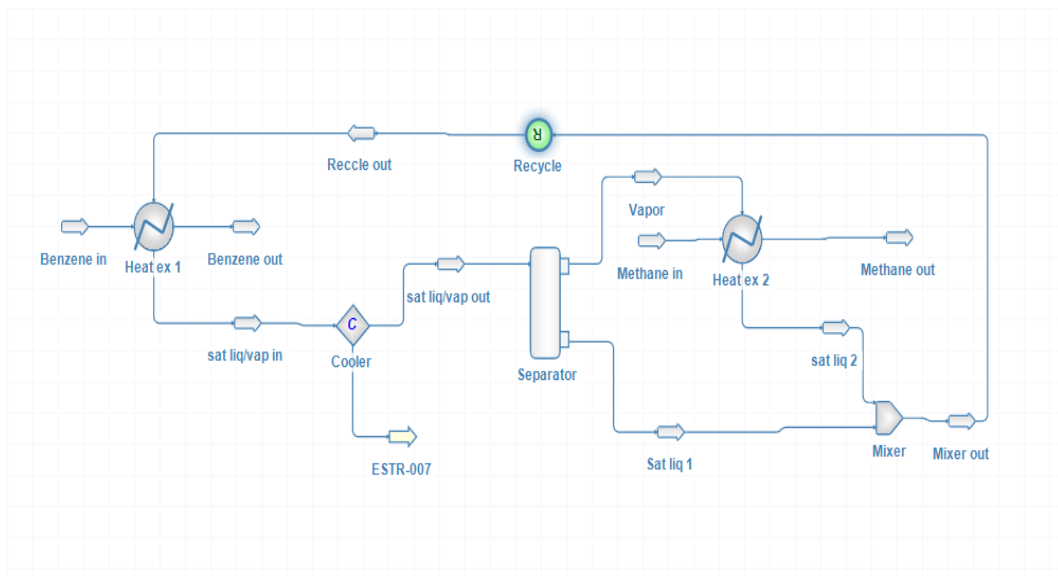

Benzene and methane, which are cooled and heated, are sent into the heater and cooler. Water,

which is the medium for the heat exchange between benzene and methane, is sent to the heater and it increases its temperature by taking heat from benzene. It then enters the mixer and the separator, which separates the vapor/liquid water into saturated vapor and liquid. Saturated vapor enters the cooler and turns into saturated liquid and is recycled to the mixer. Saturated liquid from the separator is also recycled in to the mixer. Heat released in the mixer is used to increase the temperature of methane.

URL: <https://dwsim.fossee.in/flowsheeting-project/dwsim-flowsheet-run/165>

2.68 Production of Vinyl Chloride via Direct Chlorination of Ethylene

Author: Boddupally Manoj Kumar

Institution: National Institute of Technology Warangal

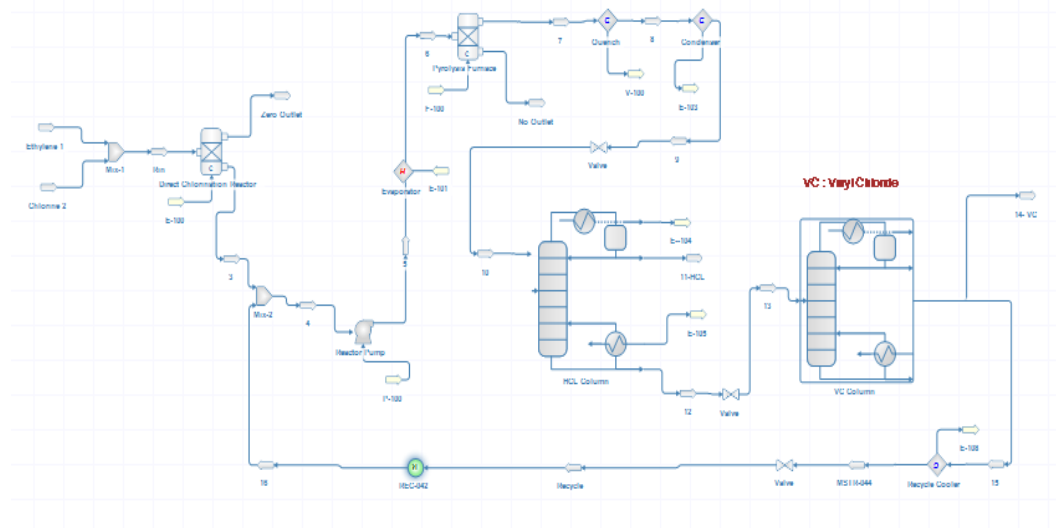

Vinyl chloride is an organochloride with the formula $H_2C = CHCl$, and is also called vinyl chloride monomer (VCM) or chloroethene. This colorless compound is an important industrial chemical, chiefly used to produce the polymer polyvinyl chloride (PVC).

Vinyl chloride is produced from ethylene in a two step process.

- First, ethylene reacts with chlorine to produce ethylene dichloride.
- The purified ethylene dichloride undergoes selective cracking to form vinyl chloride.

EDC (ethylene dichloride) is prepared by reacting ethylene and chlorine. In the presence of iron (III) chloride as a catalyst, these This process results in high purity EDC and high yields.

- C_2H_4 and Cl_2 are mixed and sent to the direct chlorination reactor.
- The conversion in the direct chlorination reactor is assumed to be 100%, while that in the pyrolysis reactor is only 60%.
- Further, both the columns are assumed to carry out perfect separations, with the temperatures of overhead and bottoms computed based on dew- and bubble-point temperatures, respectively.
- The products from the pyrolysis furnace are cooled and sent to the HCL column where HCL is removed as a overhead product and the bottoms, which include vinyl chloride and 1,2- dichloroethane, are sent to the second distillation column.

- The vapor product from the VC column is vinyl chloride and the bottoms are 1,2-dichloroethane. This is sent to be recycled, to increase the production.

URL: <https://dwsim.fossee.in/flowsheeting-project/dwsim-flowsheet-run/169>

2.69 Pressure Swing Distillation for Methanol - Chloroform Separation

Author: Abhinandan Nabera

Institution: National Institute of Technology, Tiruchirappalli

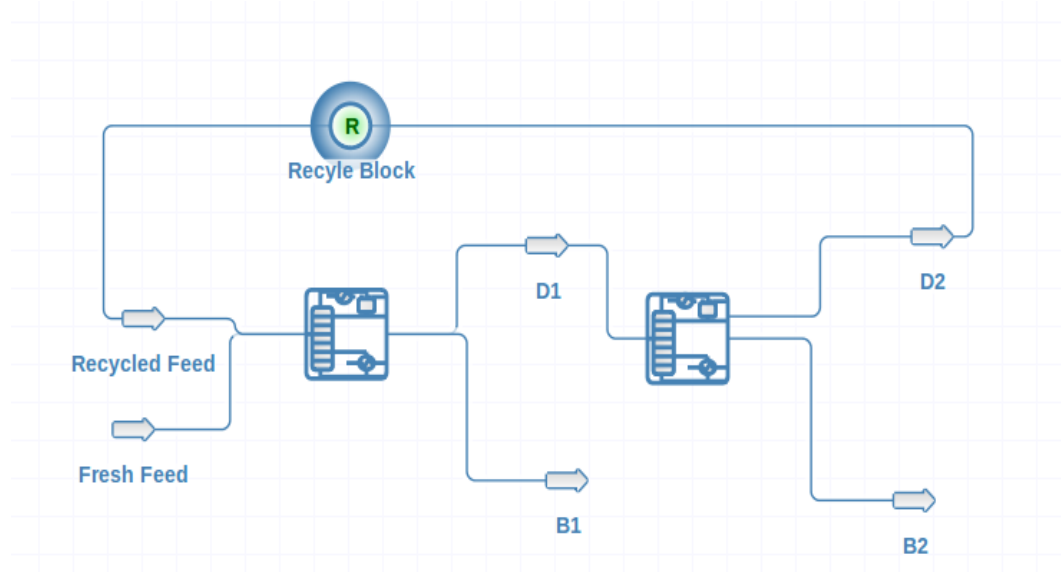

Methanol is the simplest alcohol, being only a methyl group linked to a hydroxyl group. It is a light, volatile, colorless, flammable liquid with a distinctive odor very similar to that of ethanol (drinking alcohol). However, unlike ethanol, methanol is highly toxic and unfit for consumption. Chloroform, or trichloromethane, is an organic compound, with the formula CHCl_3 . It is a colorless, sweet-smelling, dense liquid that is produced on a large scale as a precursor to PTFE. It is also a precursor to various refrigerants. The binary mixture of methanol–chloroform exhibits a minimum-boiling azeotrope with approximately 34 mol% methanol at 327 K under atmospheric pressure.

In this process, first the feed stream containing 0.5 mol fraction methanol and 0.5 mol fraction chloroform is sent to a distillation column which has 24 stages. The feed is sent to stage number 9, whereas the recycled feed is sent to stage number 18. The flow rate of the feed is around 100 kmol/hr, 300 K and the recycle ratio of the tower is 0.55. The first distillation column produces a bottom with 0.995 mol fraction methanol. The distillates of the first column are sent to a second distillation column. The second distillation column has a reflux ratio of 0.95 and it produces distillates which are recycled back to the first distillation column, and the bottom product has a composition of 0.995 mol fraction chloroform. The first distillation column is a low pressure distillation column maintained at a pressure of 1 atm, whereas the second distillation column is a high pressure distillation column maintained at a pressure of 10 atm.

URL: <https://dwsim.fossee.in/flowsheeting-project/dwsim-flowsheet-run/123>

2.70 Production of Benzene via HydroDeAlkylation of Toluene

Author: Limpho Percy Masoabi and Abdul Azeez

Institution: B.M.S. College Of Engineering

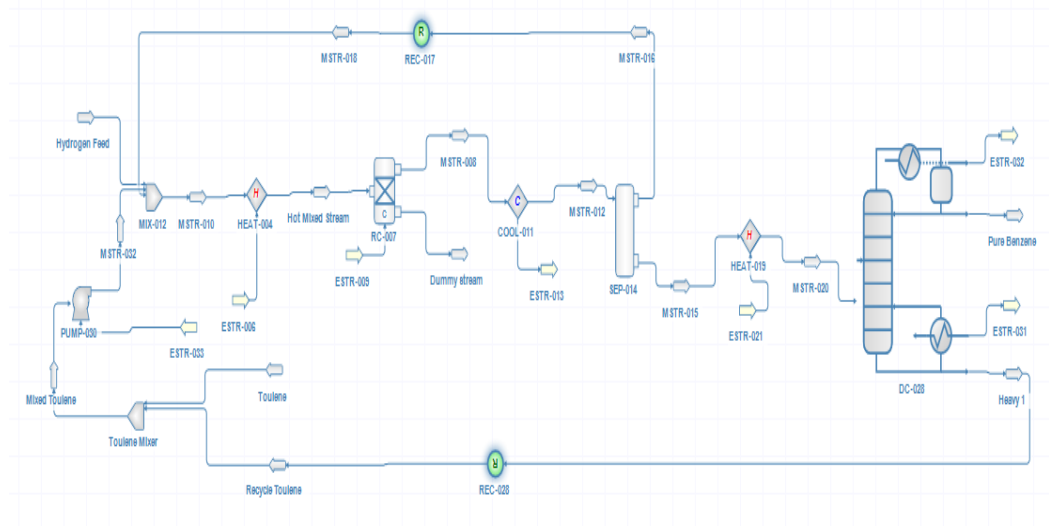

Hydroalkylation is a chemical reaction that often involves the reaction of an aromatic hydrocarbon, such as toluene, in the presence of hydrogen gas to form a simple aromatic hydrocarbon devoid of functional groups. This chemical process usually occurs at a high temperature, at high pressure, or in the presence of a catalyst. Hydroalkylation of toluene is synergized by poly-isopropyl benzene, which is obtained in the process of the manufacture of cumene as the distillate. The process is to obtain benzene from dealkylation in the presence of H_2 . In the process, the pure benzene of 96.43% is obtained, while about 96.7% of Toluene is recycled back to the feed stream. Various hydroalkylation processes can be used, in which hydrogen and alkyl aromatic hydrocarbons are contacted in a reaction zone at high temperature.

The property package used for the complete flow diagram is the SRK Model. Hydrogen and toluene are fed to their respective feed streams and are mixed in the mixer (MIX-012). The mixture feed is obtained from the material stream (MSTR-010). The product of the mixture passes through the heater (HEAT-004), where calculations are based on an outlet of 873.15K and the efficiency is 100%. The hot mixture from the heater is fed to the conversion reactor RC-007. In the reactor, toluene is made to react with hydrogen to produce benzene and methane.

The reactor operates at 600 K to 650 K and 35-40 atms, the product stream from the reactor is passed through a cooler (COOL-011) of an outlet temperature of 353.15 K, with a 100% efficiency. The products are then separated in the separator vessel, where the vapor stream and light liquid streams are separated into MSTR016 and MSTR-015 respectively. The vapor is recycled back to the mixture, while the light liquid stream is passed through the heater HEAT-019, with an outlet temperature of 373.15 K. The product is then fed to the distillation column (DC-028). From the distillation column, pure benzene is obtained as a distillate, while toluene is recycled back to the toluene mixture. The recycled toluene and fed toluene are pumped to the mixture MIX012.

URL: <https://dwsim.fossee.in/flowsheeting-project/dwsim-flowsheet-run/181>

2.71 Production of Nitric Acid by Ammonia Oxidation Process

Author: Doshi Varunkumar Rahulbhai

Institution: Shroff S. R. Rotary Institute of Chemical Technology (GTU)

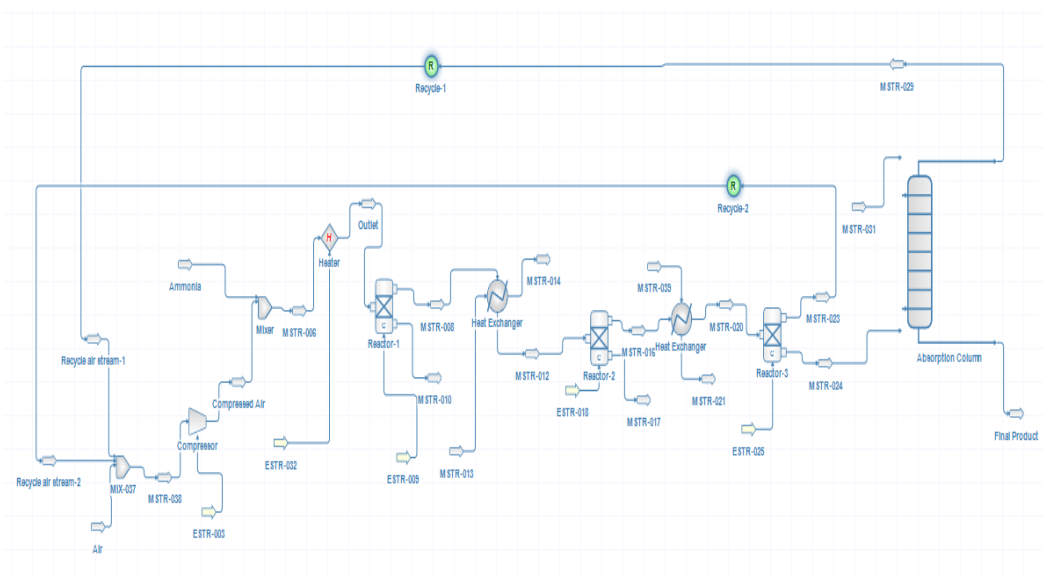

HNO_3 is mostly used for manufacturing ammonium nitrate, which is widely used in the fertilizer industry. Some manufacturers in India are Dipak fertilizers and petrochemicals, Vijay Gas Industry, Chemtex Speciality Ltd. etc. In India.

The air is compressed in the compressor. Around 3 atm pressure is achieved in the compressor. Ammonia and compressed air are sent to the mixer. From the mixer, the composition is found to consist of 90 % air and 10 % ammonia (For recycle, contents may largely vary). Then, this stream is superheated to $6000^\circ C$. The superheated stream goes into the reactor. This reaction is exothermic. So, the temperature reaches around $8000^\circ C$. Here, air reacts with ammonia and produces nitric oxide and water. The product stream then exchanges its heat in the heat exchanger. Then, the nitric oxide is converted into nitrogen dioxide. Here, some nitric acid is also formed. Again, the product stream exchanges its heat through the heat exchanger. The product stream goes into the third reactor and here we get most of the nitric oxide. Nitric oxide is absorbed in water using the absorber. Here, the unreacted products get separated. We get diluted HNO_3 from the absorber. The lean HNO_3 stream is recycled to the fresh air stream. This stream contains a higher content of air. From the oxidation reaction, unreacted air is also recycled to the main air stream.

URL: <https://dwsim.fossee.in/flowsheeting-project/dwsim-flowsheet-run/175>

2.72 HydroDeAlkylation of Toluene to Benzene

Author: Sanagapalli Venkata Karthik

Institution: National Institute of Technology Warangal

The hydrodealkylation of toluene₁ (HDA) is a process used to produce benzene, methane and diphenyl. Hydrodealkylation is a chemical reaction that often involves the reaction of an aromatic hydrocarbon, such as toluene, in the presence of hydrogen gas, to form a simpler aromatic hydrocarbon devoid of functional groups. Another example is the conversion of 1,2,4-trimethylbenzene to xylene.

Toluene and hydrogen are converted in a conversion reactor to produce benzene and methane. Typically, the reaction reaches a conversion of 70%. The reaction is highly exothermic and the typical operating conditions are $600^\circ C$ to $660^\circ C$, and 35 bar-40 bar. The HDA process begins by mixing fresh toluene, recycled unreacted toluene, hydrogen and the recycled product from the flash separator. The mixing is achieved in a storage tank. The product stream from the mixer is sent to a heat exchanger to heat the stream. The mixture is preheated before it is introduced to the heater or furnace. In the

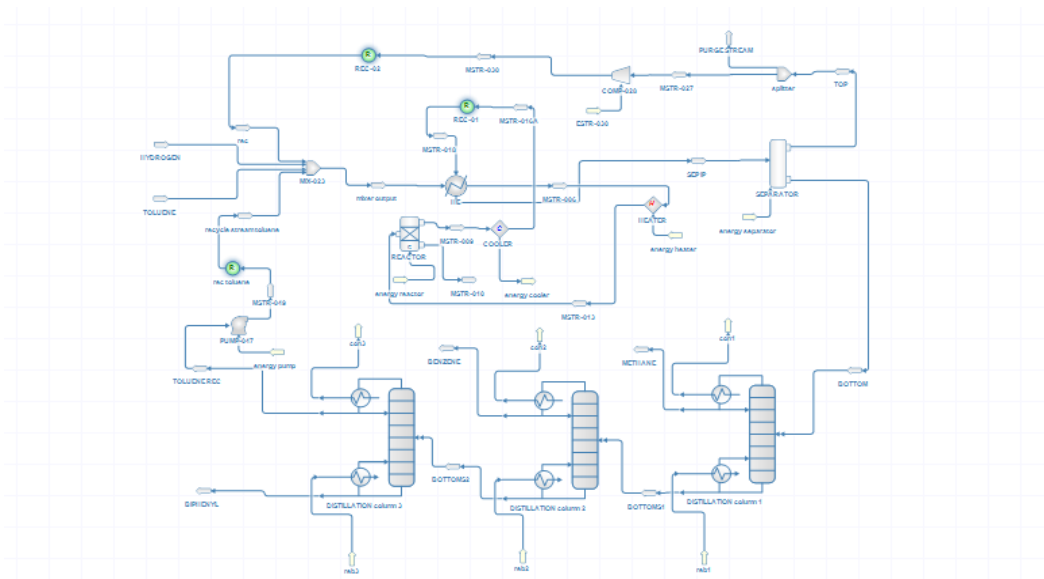

furnace, the stream is heated to 625.52°C (the reaction temperature) and is then introduced into the reactor.

The product stream from the reactor is sent to the same heat exchanger and then quenched to get a temperature of 150°C - 170°C . It is then sent to a separator which operates at 32.8 bar and 38°C . The bottom from the separator is sent to distillation column 1 to separate methane as a top product; this distillation column is the demethaniser. The bottoms from the demethaniser are sent to distillation column 2 to separate benzene as a top product. The bottoms from the latter are sent to distillation column 3 to separate biphenyl as a bottom product, and the recycled stream of toluene is pumped to the mixer. The product from the separator is purged and one stream is compressed and sent to the mixer as a recycle stream.

URL: <https://dwsim.fossee.in/flowsheeting-project/dwsim-flowsheet-run/173>

2.73 Extractive Distillation for Ethyl Formate-Ethanol-Water Separation

Author: Dhvani Jain

Institution: Aditya Silver Oak Institute of Technology, Ahmedabad

ETFO-ethanol-water mixture is an intermediate in some pharmaceutical industries. Both ETFO-water and ethanol-water form minimum boiling point azeotropes. Therefore simple distillation cannot be used to separate them out. There are no studies available for the separation of this mixture hence, extractive distillation is chosen and steady state simulations carried out. Extractive distillation is used for the separation of this mixture to yield high purity ETFO, ethanol, and for the total recovery of EG (extractive solvent).

Column-I is the extractive column and column-II is the recovery column for the solvent. The azeotropic mixture of ethyl formate-ethanol-water is fed into column-I and the top products of column-I are ethyl formate and ethanol. The bottom product of column-I is the recovery stream, which is fed to column-II, where the top product is 99 wt % water and 99 wt % ethylene glycol. Ethylene glycol is then recycled back to the feed stream after cooling and adding the make-up of solvent. The make-up accounts for a loss of solvent in the distillates of column-I and column-II. The fresh feed flow rate is kept at 1000kg/hr, containing 0.53, 0.37 and 0.1 of ethyl formate, ethanol and water by mass fraction respectively at 30°C . The pressure of both columns is maintained at 101325 Pa.

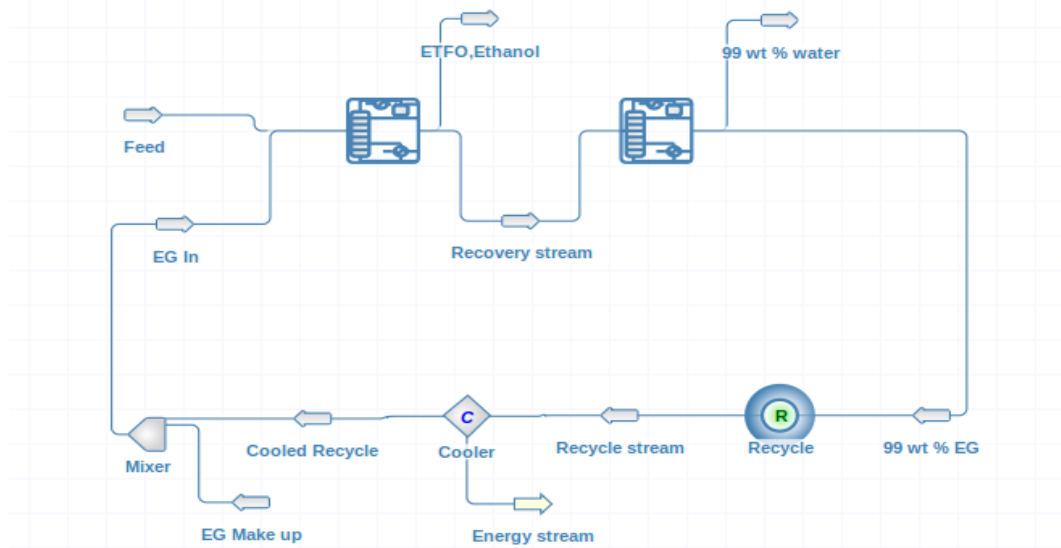

URL: <https://dwsim.fossee.in/flowsheeting-project/dwsim-flowsheet-run/166>

2.74 Simulation of C3MR LNG Refrigeration Process in DWSIM

Author: Pragneshsinh Sindha

Institution: Pacific School of Engineering, Surat

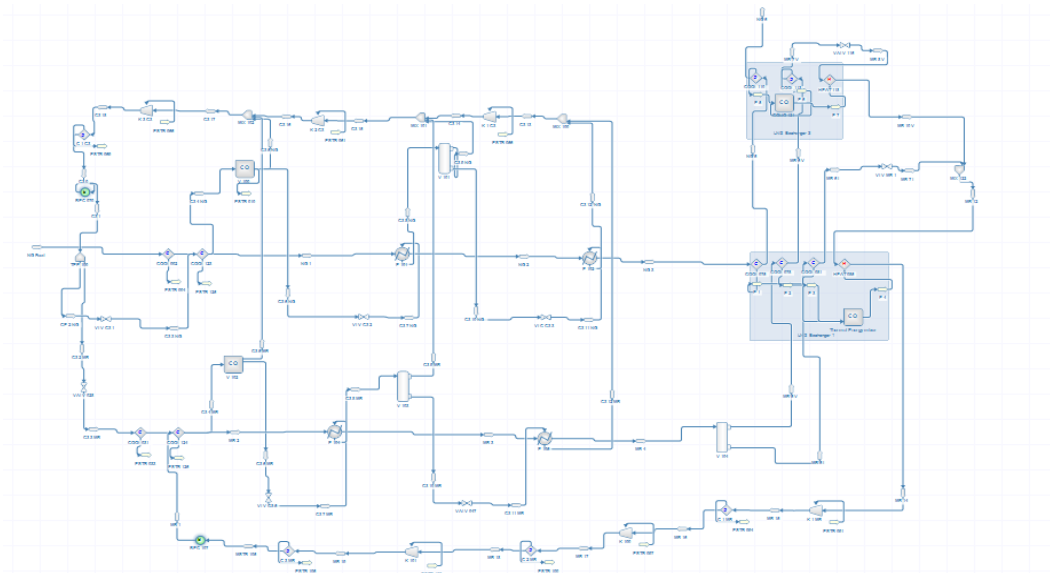

Natural gas is a viable energy source, but is dependent on the existing pipeline infrastructure in order to reach the consumers. Due to a large volume, it is not practical or economical to transport gas through vehicles or ships. Liquefied natural gas (LNG) is condensed natural gas at atmospheric pressure and approximately -162°C . The process of cooling natural gas to -162°C is highly energy demanding. Here, one of the processes simulated, known as C3MR LNG Process, is the propane pre-cooled mixed refrigerant process. This process works based on the vapor compression cycle which consists of four components: compressor, condenser, expansion valve and evaporator.

For LNG production, different refrigerant fluids are used to cool and condense natural gas to approximately -162°C . Sea water is used to cool the compressed refrigerant streams, which are subsequently expanded to cool the natural gas. The processes are extremely energy demanding and involve large compressors. So, a large saving could be made by just improving the operating conditions slightly. LNG processes may be operated with pure or mixed refrigerants, though mixed refrigerants have the advantages of providing a much closer fitting cooling curve in the heat exchanger with natural gas. A pure refrigerant gives a large temperature difference in the warm end of the heat exchanger, and therefore a low COP. It is necessary to use multiple cascades of pure refrigerant cycles to obtain results that are comparable to those of mixed refrigerants.

The propane pre-cooled mixed refrigerant (C3MR) process involves a single mixed refrigerant cycle. However, as its name suggests, the process also consists of a propane pre-cooling cycle. This single component refrigerant eases the duty of the mixed refrigerant by cooling the natural gas and the refrigerant itself before the main cryogenic heat exchanger.

In this flowsheet, the propane cycle is used to pre-cool the mixed refrigerant. Propane is compressed to a high enough pressure. This is done due to the pressure being high enough for propane to be in the liquid phase at the temperature achieved by cooling. The pressure of the liquid propane stream is let down and it is vaporized by the heat exchanger with natural gas and the mixed refrigerant. The pressure let down and heat exchange is performed in three stages, where the propane vapor is sent back for compression after each stage. The final heat exchanger in the propane cycle must superheat the propane in order to avoid liquid being fed to the first compressor. After pre-cooling, the mixed refrigerant is partially condensed and is sent to a high pressure separator prior to entering the main cryogenic heat exchanger. The vapor and liquid MR streams pass through separate circuits in the main cryogenic heat exchanger and are cooled, liquefied and sub-cooled through the internal heat exchange along with natural gas. The liquid refrigerant stream is taken out and expanded at a point other than that for the MR vapor. As the low pressure refrigerant streams flow down the cryogenic heat exchanger, they are vaporized and superheated by the cooling of natural gas (and also MR streams). The superheated low pressure mixed refrigerant is then recompressed and cooled to complete the cycle. From the result of this process, we have a high pressure natural gas stream of approximately -157°C temperature.

URL: <https://dwsim.fossee.in/flowsheeting-project/dwsim-flowsheet-run/171>

2.75 Isopropyl Alcohol Dehydration Process

Author: Miteshkumar Bhailalbhay Patel

Institution: Aditya Silver Oak Institute of Technology, Ahmedabad

Isopropyl alcohol dissolves a wide range of non polar compounds. It is used widely as a solvent and as a cleaning fluid, especially for dissolving oils. It is primarily produced by combining water and propene in the hydration process. Both processes require a separation of isopropyl alcohol from water and other by-products by distillation.

The binary mixture of 80 wt% isopropyl alcohol (IPA) and 20% water is fed to column 1. The bottom product is around 98 wt% of water and the distillate is around 86 wt% of IPA, which is fed to column 2 with the extractive solvent of ethylene glycol. The distillates of column 2 contain around 98 wt% of IPA, and the bottom is fed to stage 12 of column 3. The bottoms stream of column 3 contains ethylene glycol, which is cooled and recycled back to column 2. The flow-sheet is as shown:

URL: <https://dwsim.fossee.in/flowsheeting-project/dwsim-flowsheet-run/172>

2.76 Benzene-Cyclohexane Separation System via Extractive Distillation

Author: Mehulkumar Sutariya

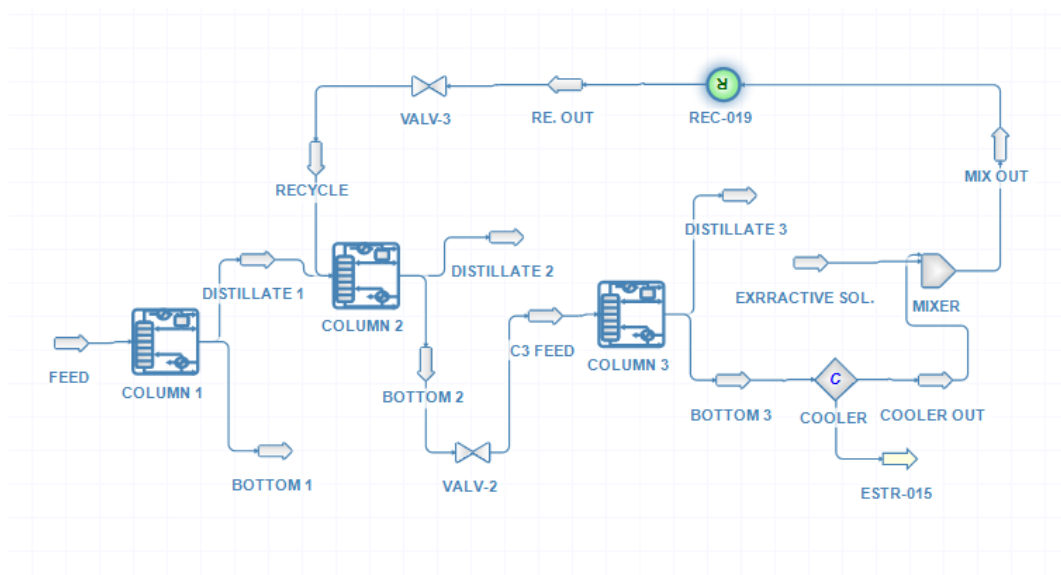

Institution: Sardar Vallabhbhai National Institute of Technology, Surat

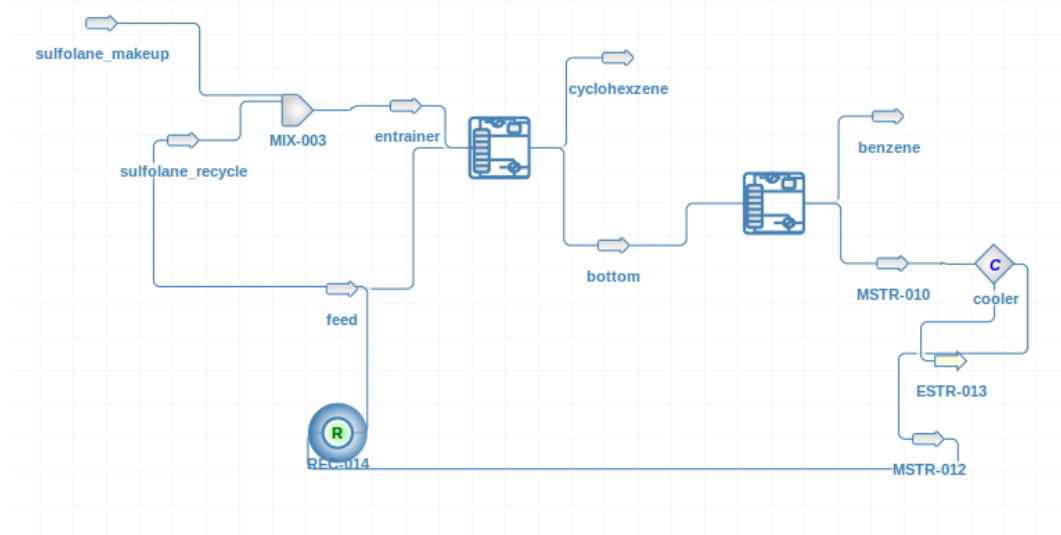

Hydrocarbons like benzene and cyclohexane are important raw materials in the petrochemical industry. They often require high-purity cyclohexane and benzene, which is widely used in the polymer industry, in the synthesis of pharmaceutical intermediates and in many others. Cyclohexane is mainly produced by the hydrogenation of benzene. Due to the high tendency of aromatic hydrocarbons to form an azeotropes with non-aromatics, this reaction often gives us an azeotropes of benzene and cyclohexane, which must be separated out to obtain highly pure cyclohexane and benzene.

The flow sheet contains two distillation columns, namely, 'Extractive distillation column' and 'Entrainer recovery column'. Here, we use sulfolane as the entrainer and the mixture of benzene and cyclohexane as the feed. The presence of sulfolane alters the relative volatility between benzene and cyclohexane to make cyclohexane move towards the top part and benzene move to the bottom part of the column.

The extractive distillation column takes the entrainer and feed and provides pure cyclohexane as the top product, and the bottom product which has benzene and sulfolane, enter the entrainer recovery column; which separates benzene and sulfolane. This recovered sulfolane is recycled to the extractive

distillation column.

URL: <https://dwsim.fossee.in/flowsheeting-project/dwsim-flowsheet-run/191>

2.77 Pressure Swing Distillation System for Methylal/Methanol

Author: Mehulkumar Sutariya

Institution: Sardar Vallabhbhai National Institute of Technology, Surat

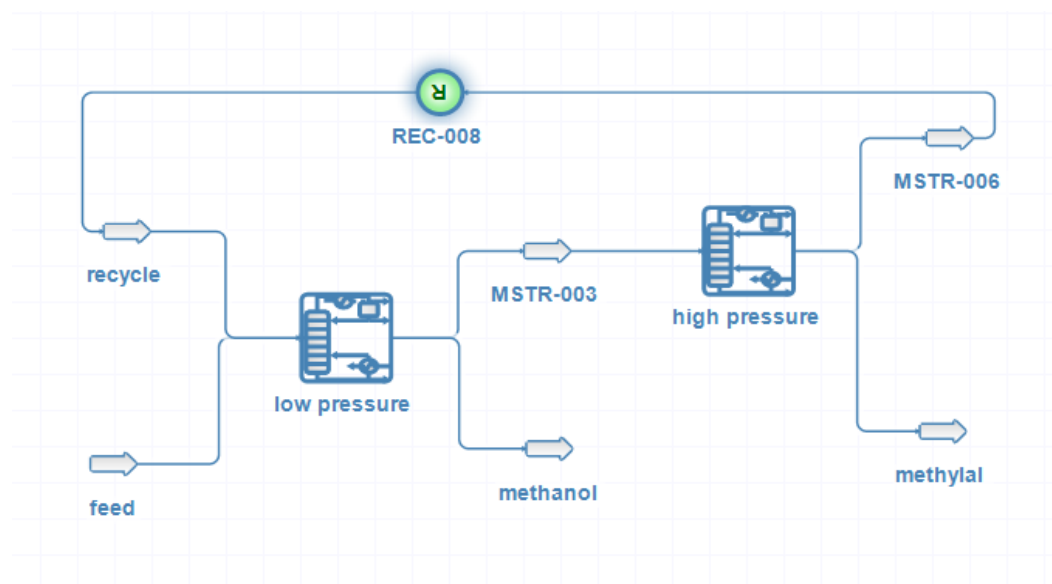

Industrially, methylal is used as a solvent in the synthesis of aerosol, manufacture of perfumes, resins, adhesives, insecticides, paint strippers and protective coatings. It is also a cleaning diesel additive and a substitute for freon. Methylal is synthesized by the reaction of methanol with formaldehyde or paraformaldehyde in the presence of a catalyst. Because of the high non-ideality in the liquid phase, a minimum-boiling azeotrope is formed between methylal and methanol. obtain highly pure methylal for industrial purposes, we have to break the azeotrope. For that, there are many methods like extractive distillation, membrane pervaporation, pressure swings distillation etc. When the azeotrope is pressure sensitive, pressure swing distillation is used to obtain highly pure compounds.

Here, we use two distillation column with different pressures (100 kPa and 1200 kPa). In the low pressure column, we insert the feed. This feed is concentrated near the azeotropic composition at 100 kPa, and the methanol is collected from the bottom. The top stream of the low pressure column now enter the high pressure column, where its composition is changed with the azeotropic composition at 1200 kPa, and the pure methylal is collected from the bottom of that column. The top stream of the high pressure column is recycled to the low pressure column.

URL: <https://dwsim.fossee.in/flowsheeting-project/dwsim-flowsheet-run/193>

2.78 Production of Vinyl Chloride from Ethylene

Author: Pavan Nayak

Institution: B.M.S. College of Engineering

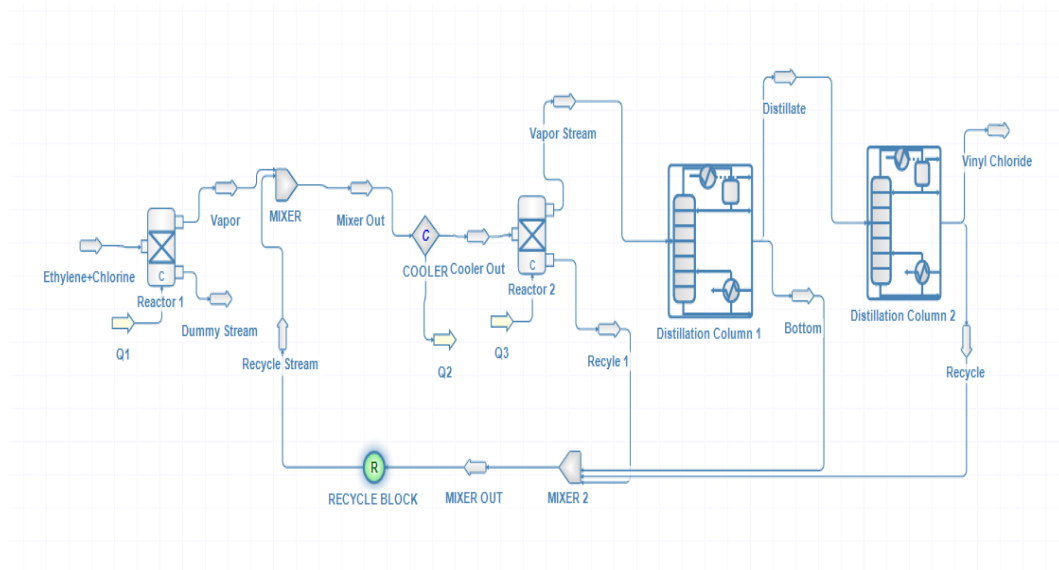

Vinyl chloride is an organochloride, whose colorless monomer is an important industrial chemical, chiefly used to produce the polymer polyvinyl chloride (PVC). It is produced by vapor phase conversion reactions, with ethylene and chlorine as reactants. In the first conversion reactor, ethylene and chlorine react to produce ethylene dichloride. Both the vapor and liquid stream, along with the recycle stream, is taken into the second reactor.

In the second reactor ethylene dichloride splits into vinyl chloride and hydrogen chloride (HCl). Since, the product stream is a mixture of various compounds, this stream has to undergo a separation process, hence distillation plays a crucial role. The liquid stream of the second reactor is taken, as the recycle and vapor stream are taken into the 40 stage distillation column. This column separates vinyl chloride from other compounds. The vapor stream contains 83% pure vinyl chloride. For further purification, this stream is taken into the second distillation column, where the undesired compounds are removed, giving 100% pure vinyl chloride as products. The liquid stream is sent back for to be recycled, for better yield.

URL: <https://dwsim.fossee.in/flowsheeting-project/dwsim-flowsheet-run/73>

2.79 Refrigerated-Purge Distillation Columns

Author: Mehulkumar Sutariya

Institution: Sardar Vallabhbhai National Institute of Technology, Surat

To remove heat from the condenser of the distillation column, in industries, cooling water is used most of the time, because of its less expansive nature. But when the distillate contains a low boiling compound, it requires high pressure inside the column. The high column pressure makes the separation between the light- and heavy-key components difficult, which results in high energy consumption. To avoid this, there is one alternative solution, namely, Refrigerated-Purge Distillation Columns.

In Refrigerated-Purge Distillation Columns, We use two columns at a pressure lower than that of the conventional column. The first column (or the main column) concentrates the useful compounds at the distillate stream, yet, it is not at a desirable concentration. There is a considerable amount of the heavy compounds. Here, we use a partial condenser, which gives the most of the vapour in the distillate stream. This enters the second column, which is at a lower pressure (here 2 psia lower) and temperature (of the condenser) than the first column. In this second column, we are able to achieve the desired purity of the light-key compounds.

The feed contains 5 mol/mol% of useful light-key components, which enter the main column. This is similar to the simple distillation column, but here the condenser is partial, so the distillate is in the

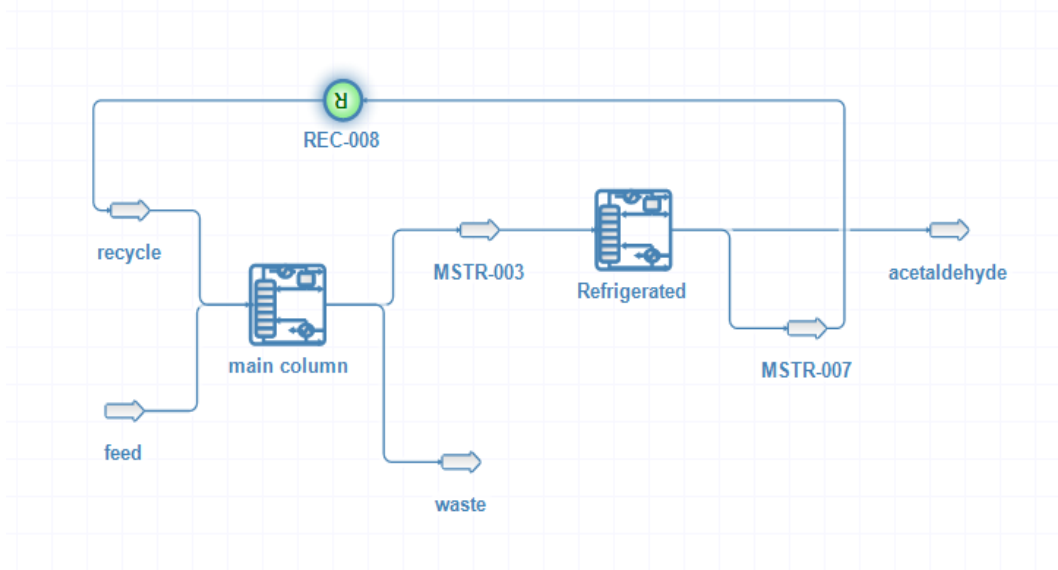

vapor form. In this main column, we try to achieve 60 mol/mol% of useful light-key components in the distillate stream. This distillate stream is fed into the second column. Further condensation of this vapor stream is done inside this second column(which only contains the condenser, known as the stripper column). The top product of this second column is 98 mol/mol% light key compound, and the bottom product is again recycled near the top of the first columns.

URL: <https://dwsim.fossee.in/flowsheeting-project/dwsim-flowsheet-run/196>

2.80 Dry Methane Reforming Process

Author: Charan R

Institution: SASTRA Deemed University, Thanjavur

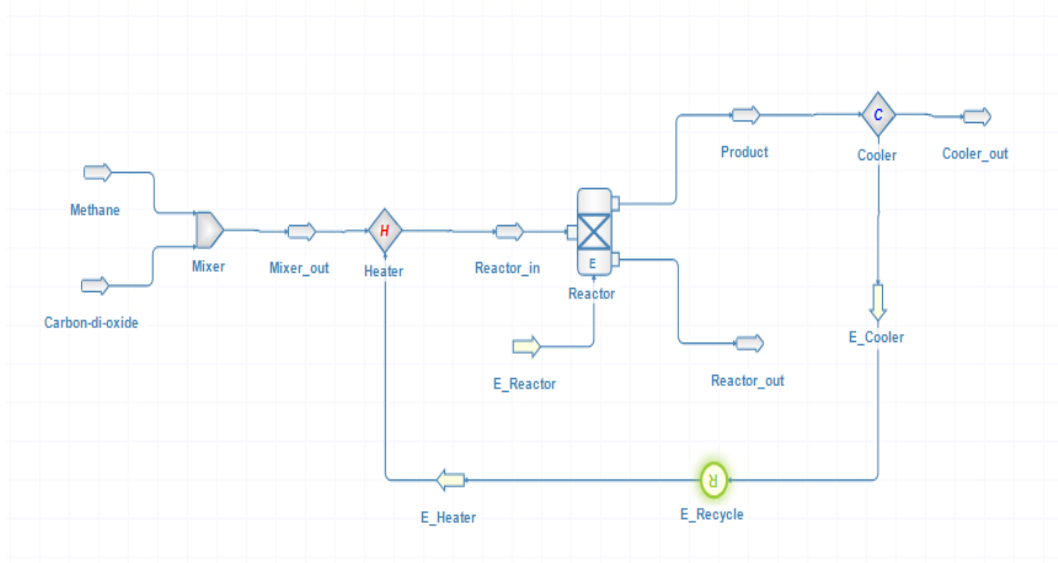

Methane is used in petrochemical industries as a precursor for the production of high quality hydrogen. This is usually done by steam reforming, where steam is made to react with methane to form carbon

monoxide and hydrogen. The dry reforming of methane is a similar process, where methane reacts with carbon dioxide instead of steam, to produce hydrogen and carbon monoxide (syngas). This process is usually favored at low temperatures and high pressures. Dry reforming of methane is environmentally very attractive, as it utilizes two greenhouse gases to give a useful product.

Two feed streams containing methane and carbon dioxide respectively are sent into the mixer. The feed streams are at the same conditions of 1 atm and 50°C, with a molar flow rate of 1000 kmol/h. The mixed stream is then sent to a heater, where it is heated to 1100 K. The heated stream is then sent to an equilibrium reactor where the conversion is given at 94% for the given temperature. The product, which is syngas, with a small amount of reactants, is then cooled using a cooler. The energy generated from cooling the stream is recycled and used by the heater to heat the reactant stream.

URL: <https://dwsim.fossee.in/flowsheeting-project/dwsim-flowsheet-run/197>

2.81 Control of an Extractive Distillation Process to Dehydrate Ethanol using Glycerol

Author: Pragneshsinh Sindha

Institution: Pacific School of Engineering, Surat

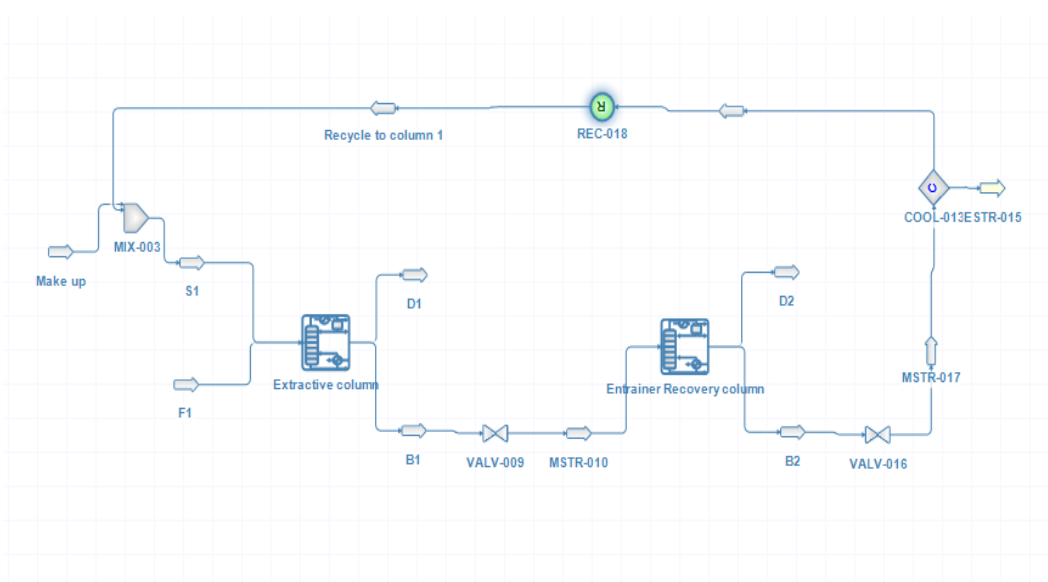

Here, simulation is carried out for the ethanol separation from the water, using glycerol as the entrainer. For pure ethanol, which is used as fuel or for other applications, it's important to remove the water content from that. However, the ethanol-water mixture makes a minimum-boiling homogenous azeotrope at 78.1°C, composed of 89mol% ethanol, which may separate through azeotropic distillation using various solvents including cyclohexane, iso-octane, and benzene. Here, I used extractive distillation for the separation of ethanol and water, taking glycerol as the separating agent. Extractive distillation is known as a technique which uses non-volatile, high boiling point separating agents for the separation of a mixture (which forms an azeotrope), which called an entrainer.

NRTL property package is used. It is also used in the simulation of the distillation column, for activity coefficient calculation. However, parameters are adjusted to get feasible results.

Two columns are used for the separation of the ethanol-water mixture, namely, the 'extractive column' and the 'entrainer recovery column'. From the extractive column, we get pure ethanol that has a purity of 97.67%. Here in flowsheet it is named as D1 stream. From the bottom product stream, we get a mixture of glycerol and water, which is further separated in the entrainer recovery column. From that, as the top product, water is removed and as the bottom product, pure glycerol is obtained. This is further

recycled to the extractive column, with a small addition of make-up that has a molar flow rate of 0.045 kmol/h. However, to control the purity of ethanol, we also used a cooler to maintain the temperature of the entrainer feed due to lower reflux operation (It is observed that without the cooler, if the entrainer feeds the column, it is necessary to increase the reflux for getting desired results, due to which water vaporizes stage-wise which decreases the purity of ethanol)

URL: <https://dwsim.fossee.in/flowsheeting-project/dwsim-flowsheet-run/194>

2.82 Study on the Effects of Inerts on Water-Gas Shift Reaction

Author: Charan R

Institution: SASTRA Deemed University, Thanjavur

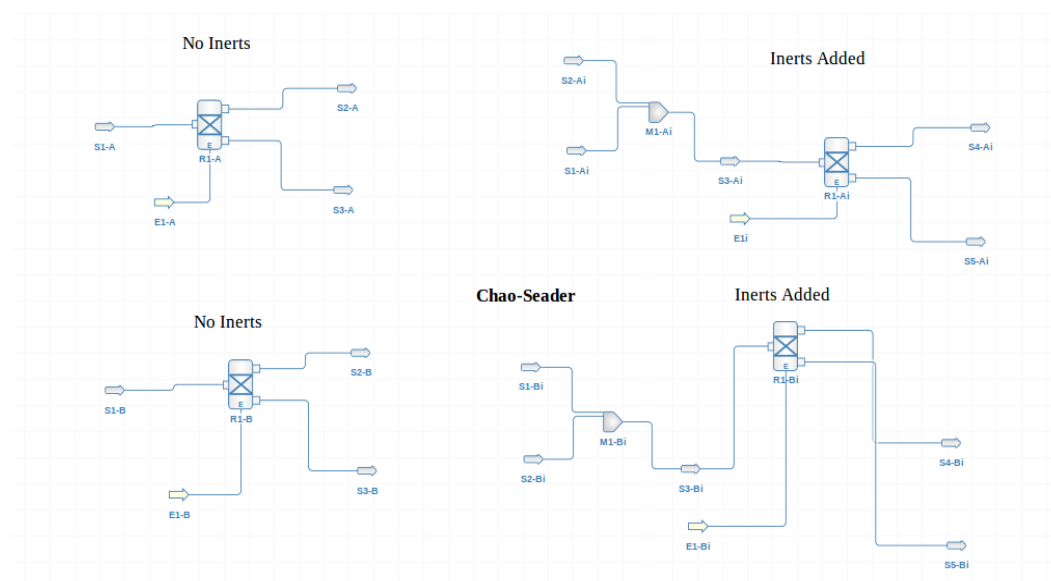

For equilibrium reactions, the addition of inert compounds can shift the equilibrium to either the forward or backward reaction. The extent to which the addition of inert compounds affects the equilibrium is calculated by applying the principle of reaction equilibrium, and in turn is dependent on the solution thermodynamics of the system. Thus, the thermodynamic model used to predict the solution behavior can impact the equilibrium conversion. To illustrate this, a simple case study based on Paiva (2008) is illustrated in this work. A water gas shift reaction is simulated in an equilibrium reactor, operated isothermally using two different thermodynamic models to describe the system. The same reaction is further simulated, with an addition of an inert gas (Xenon). The results are compared to arrive at an appropriate inference.

The feed, consisting of 50 mol% water and 50 mol% carbon monoxide, flows at the rate of 360 kmol/h, at a temperature of 326.85°C and 100 bar pressure. The feed is fed into an equilibrium reactor, operated isothermally. In a similar process, the feed that consists of water and carbon monoxide, is mixed with an equi-molar amount (180 kmol/h) of an inert gas (Xenon) and then sent to an equilibrium reactor. The process is simulated using two thermodynamic models (Raoult's Law and Chao-Seader) to understand the effect of the non-ideal nature of the components on reaction equilibria. This process flow-sheet is based on Paiva (2008).

It is seen that the thermodynamic model has an impact upon the equilibrium state of the reaction. The effect of exothermic reaction is dependent on the thermodynamic model which is used to describe the system. Thus, the effect of the inert gas on the reaction equilibrium needs to be ascertained with a sound know-how of the solution thermodynamics of the system. This case study shows that a free and

open source simulator can be used as an effective learning tool to simulate, and thereby demonstrate, the importance of the usage of appropriate thermodynamic models in process simulation.

URL: <https://dwsim.fossee.in/flowsheeting-project/dwsim-flowsheet-run/203>

2.83 Production of Styrene from Benzene and Ethylene

Author: Aakash Subramanian S.

Institution: SASTRA Deemed University, Thanjavur

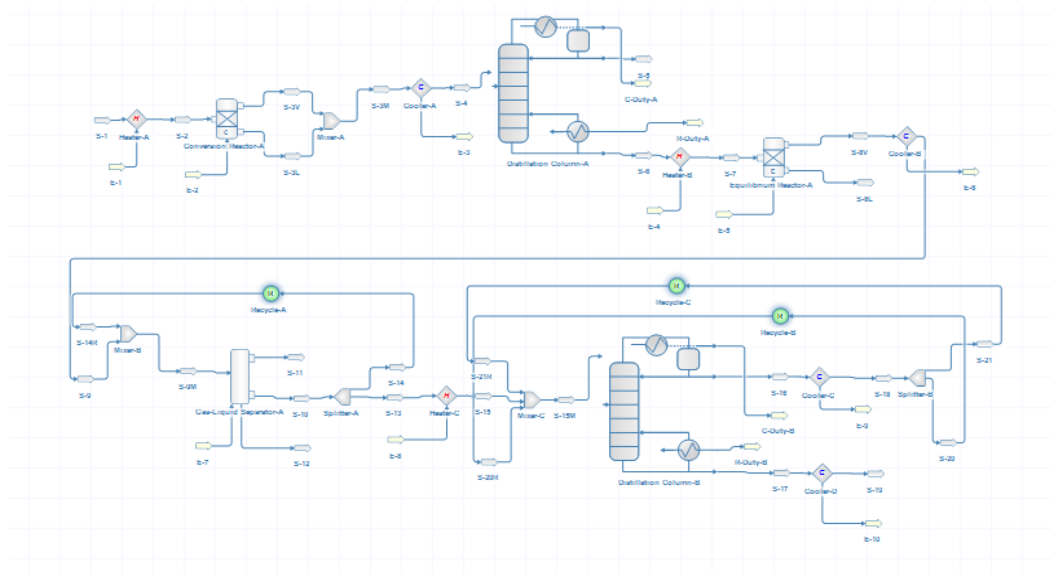

Styrene is the raw material for the manufacture of a number of commodities, functional thermoplastics and thermosetting resins such as polystyrene, styrene-butadiene, acrylonitrile, butadiene styrene and so on. Styrene is also known as ethyl benzene, vinyl benzene, and phenyl ethene. Styrene is a colorless oily liquid which gives a sweet smell on evaporation.

The feed containing an equi-molar composition of benzene and ethylene was preheated to the reaction temperature of 95°C at a constant pressure of 1.01325 bar. Then, it was fed to a conversion reactor which produces ethyl benzene at 70% conversion with respect to benzene. The product stream from the conversion reactor, containing ethyl benzene and unreacted ethylene and benzene, was sent to a distillation column. In the distillation column, ethyl benzene was obtained as the bottom product and the distillate stream contained a small amount of ethyl benzene and unreacted ethylene and benzene. The purified ethyl benzene, obtained as the bottom product, was then heated to 650°C and was fed to an equilibrium reactor which produces styrene, hydrogen and unreacted ethyl benzene. The exit stream from the equilibrium reactor was cooled to 40°C and then fed to a gas-liquid separator where hydrogen was removed as vapor stream. The liquid stream containing ethyl benzene and styrene was heated to 50°C and then sent to another distillation column, where 99.94 % pure styrene was obtained as the bottom product and hydrogen along with unreacted ethyl benzene as the top products.

The stream obtained as the top product was split into two separate streams and recycled, due to a convergence error in the recycle block, in order to increase the productivity of the process. Finally the product obtained was cooled to room temperature.

URL: <https://dwsim.fossee.in/flowsheeting-project/dwsim-flowsheet-run/205>

2.84 Production of N-Octane from Ethylene and I-Butane

Author: Hemanand T

Institution: Birla Institute of Technology and Science Pilani

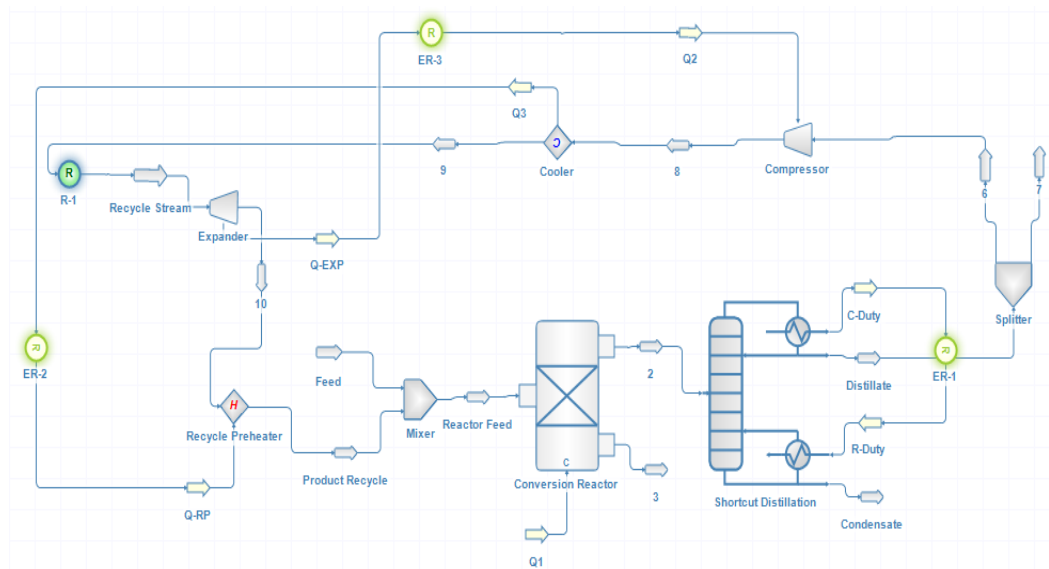

N-octane is a colorless liquid, which has a density less than that of water and it produces a gasoline-like odor. The thermodynamic model used in this flowsheet is the Peng-Robinson equation of state, as it accounts for feed materials operating at a high pressure. The reactor used is a conversion reactor, which performs the energy and mass balances based on the stoichiometry and the specified conversion.

The feed stream that consists of ethylene and i-butane in stoichiometric proportions (along with nitrogen and n-butane as inerts), is fed to the conversion reactor at 93°C and 20 psia. The other stream coming out of the reactor, which is ethylene rich, is passed through a shortcut distillation column. A shortcut distillation column is used, which performs calculations based on the Fenske-Underwood-Gilliland model. The condenser chosen is a partial condenser, with ethylene as the light key component (0.0015 mol fraction), and n-octane as the heavy key component (0.28 mol fraction).

The distillate stream contains some unconverted raw material that is recycled back. The recycle system consists of a purge stream, a compressor and a cooler with a 10% purging performed to avoid trapping of unconverted feed. The compressor is used to match the pressure of the distillate stream to that of the feed stream. A cooler unit is used to cool the temperature of the stream that has increased due to compression, to match the reactor operating temperature. The outlet of the cooler is passed through a recycle unit and is finally mixed with the feed stream. The stream coming out of the recycle unit (R-1 in flowsheet) has a higher pressure (+4 psia) and a lower temperature (-5°C after passing through expander) than needed for the feed stream. Hence, it is passed through an adiabatic expander and a recycle preheater before being mixed with the feed stream. The flow-sheet is integrated in such a way that the condenser duty is recycled and fed to meet the reboiler duty needs; Similar to the way in which the energy stream coming out of the cooler is recycled to the preheater.

URL: <https://dwsim.fossee.in/flowsheeting-project/dwsim-flowsheet-run/163>

2.85 Production of Aniline from Nitrobenzene and Hydrogen

Author: Charan R

Institution: SASTRA Deemed University, Thanjavur

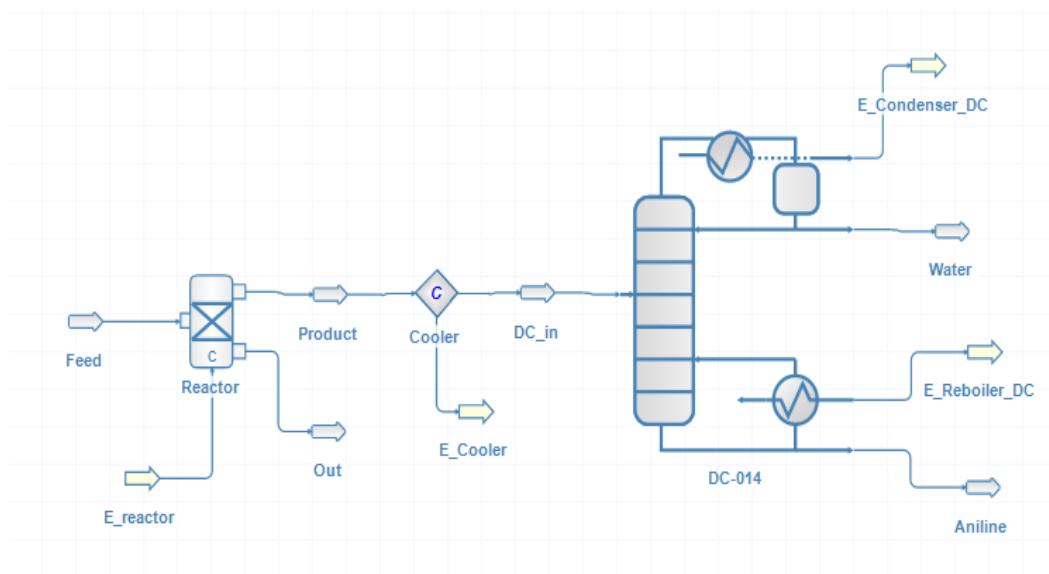

Aniline, also known as amino benzene or benzenamine, is an aromatic amine with the formula $C_6H_5NH_2$. It is mainly used as a raw material in the production of methylene diphenyl diisocyanate (MDI), an intermediate in polyurethane manufacture. MDI production alone accounts for over 95% of aniline consumption in the world. Aniline is also used as an intermediate for dyes and pigments, explosives, agricultural chemicals and pharmaceuticals. It was first commercially produced using nitrobenzene as a starting material around 1930. This pathway remains the most common method for aniline production today. Currently, almost all existing plants producing aniline from nitrobenzene are integrated with facilities to produce nitrobenzene from benzene.

The flow-sheet simulates the production of 10 TPD of aniline from nitrobenzene with the addition of hydrogen. The feed stream consists of nitrobenzene and hydrogen. The composition of the feed stream is 75% hydrogen and 25% nitrobenzene. The feed is sent at the conditions of 600 K, 1 atm and at a mass flow rate of 600 kg/s. This stream (feed) is sent to a conversion reactor where the conversion of the reaction is fixed at 99.9%. Since the conversion is very high, the product stream from the reactor has a composition of 33% aniline and 66% water, with negligible amounts of the reactants (approx.1%). The product stream is then passed through a cooler, where it is cooled to 300 K. The cooled water is then sent to the distillation column, where water is removed through the distillate stream and aniline is obtained through the residue stream. Aniline obtained is at a purity of almost 99 %.

URL: <https://dwsim.fossee.in/flowsheeting-project/dwsim-flowsheet-run/206>

2.86 Effect of Column Sequence on the Separation of Compounds

Author: Charan R

Institution: SASTRA Deemed University, Thanjavur

In this work, two different sequences of distillation columns are simulated to separate a mixture containing aliphatic alcohols, namely methanol, ethanol and 1-propanol.

Consider a typical separation process where a mixture of three aliphatic alcohols such as methanol, ethanol and propanol are required to be separated using a distillation column. The normal boiling points of these three components are 338 K, 352 K and 370 K respectively. A specification of 99.9 mol % pure component is set as target for the separation process.

To study the effect of sequencing of the distillation column, the feed is split equally using a splitter, into two streams. The split streams are sent to two different sequences of the distillation column, namely

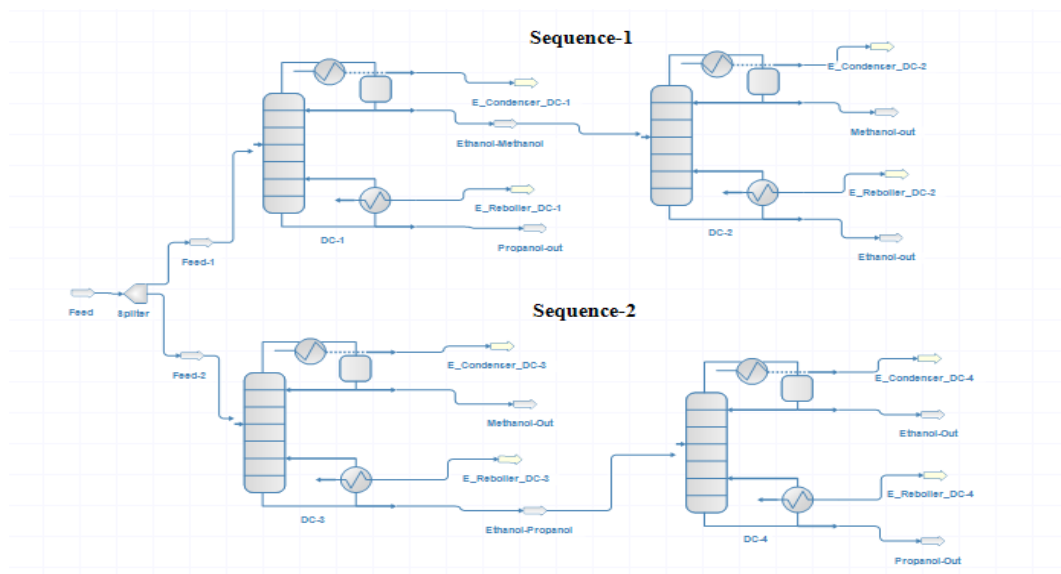

sequence - 1 and sequence - 2. In sequence - 1, 1-propanol is removed in the first distillation column (DC-1) as residual stream. The distillate from DC-1 is then sent to the next distillation column (DC-2) where methanol of required purity is obtained as the distillate, and ethanol as residue. Similarly, in sequence -2, methanol is initially removed in the first distillation column of sequence-2 (DC-3) as distillate. The residue from DC-3 is then sent to the next distillation column (DC-4), where ethanol and 1-propanol are separated and obtained as distillate and residue respectively. All the product streams are maintained at 99.9 mol% purity. The reflux ratio, condenser pressure and reboiler pressure are maintained at the same value for the purpose of comparison. For the sake of brevity, it is assumed that the components are ideal and follow Raoult's law.

URL: <https://dwsim.fossee.in/flowsheeting-project/dwsim-flowsheet-run/208>

2.87 Production of Sulfur Trioxide from Sulfur Dioxide

Author: Aakash Subramanian S.

Institution: SASTRA Deemed University, Thanjavur

Sulfur trioxide is an industrially important chemical used in the manufacture of Sulfuric acid. Gaseous Sulfur Trioxide is odorless and extremely corrosive. Liquid Sulfur trioxide is transparent and the solid form of Sulfur trioxide is crystalline in nature .

The feed containing sulfur dioxide and oxygen was first pre-heated to the reaction temperature i.e. 560°C . The pre-heated mixture was then fed to an equilibrium reactor where the oxidation of gaseous sulfur dioxide takes place, to produce Sulfur trioxide. The exit stream, which contains gaseous sulfur trioxide, unreacted sulfur dioxide and oxygen, was cooled to 75°C and then fed to a distillation column. In the distillation column, gaseous sulfur trioxide was obtained as the bottom product, and the rest as the distillate. Then the bottom product was cooled to room temperature and sent to a storage vessel.

URL: <https://dwsim.fossee.in/flowsheeting-project/dwsim-flowsheet-run/209>

2.88 Alkylation of 1-Butene to Octane and Dodecane

Author: Aakash Subramanian S.

Institution: SASTRA Deemed University, Thanjavur

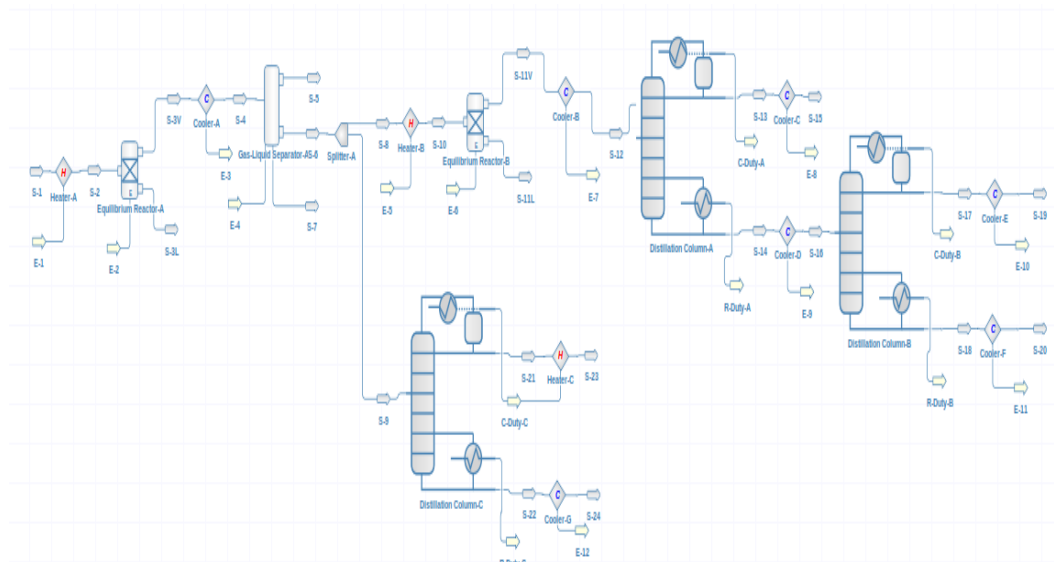
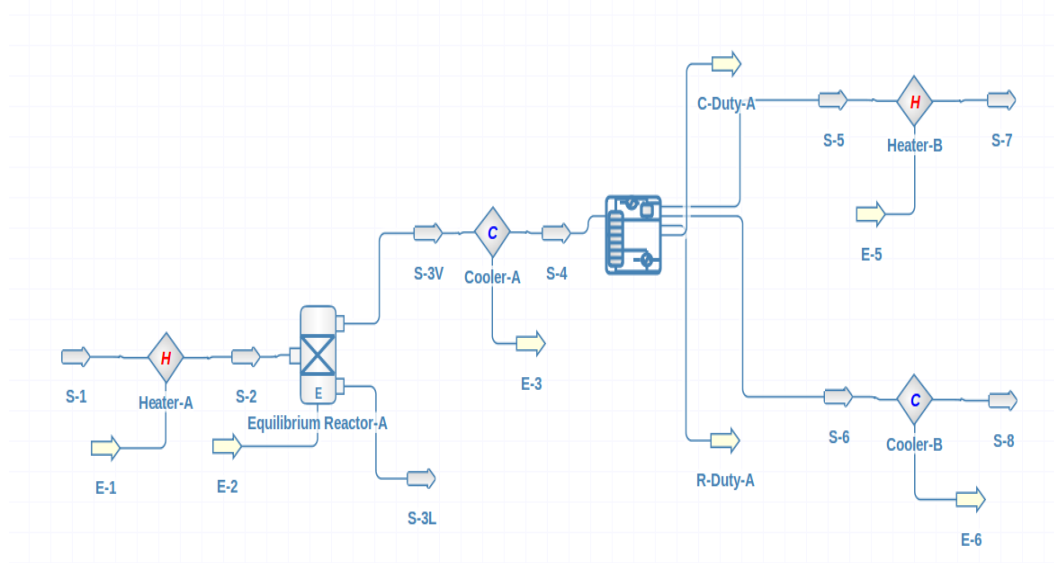

N-Octane is a component of gasoline (petrol). It is volatile and very flammable. N-Dodecane is also known as dihexyl, bihexyl, adakane 12 or duodecane. N-Dodecane is a liquid alkane hydrocarbon. This is the process simulation for the alkylation of 1-Butene to N-Octane and N-Dodecane

The feed, containing 67 mol % of 1-Butene and 33 mol % of hydrogen, was first pre-heated to a temperature of 475°C and then fed to an equilibrium reactor, where the reaction takes place at 3 bar pressure. The product stream from the reactor, containing N-Octane and unreacted 1-Butene and hydrogen, was cooled to 10°C at a constant pressure and was fed to a gas-liquid separator. In the gas-liquid separator, most of the hydrogen present in the product stream was removed as vapor, and the remaining product stream was obtained as liquid. The liquid stream was then split into two separate streams having equal mass flow rates. One stream was heated to 300°C at 3 bar pressure and was fed to another equilibrium reactor, where N-Dodecane was obtained as the product. The product stream also contains unreacted N-Octane and 1-Butene. The products were sent to a shortcut column, where 1-Butene was obtained as the distillate and N-Octane and N-Dodecane as the bottom stream. The bottom stream was then sent to another shortcut column, where N-Octane was obtained as the distillate stream and N-Dodecane as the bottoms. The second stream from the splitter was fed to another shortcut

column, where N-Octane was obtained as the bottom product and 1-Butene as the distillate. All the products were then cooled to room temperature.

URL: <https://dwsim.fossee.in/flowsheeting-project/dwsim-flowsheet-run/211>

2.89 Production of Acetic Acid from Acetaldehyde

Author: Aakash Subramanian S.

Institution: SASTRA Deemed University, Thanjavur

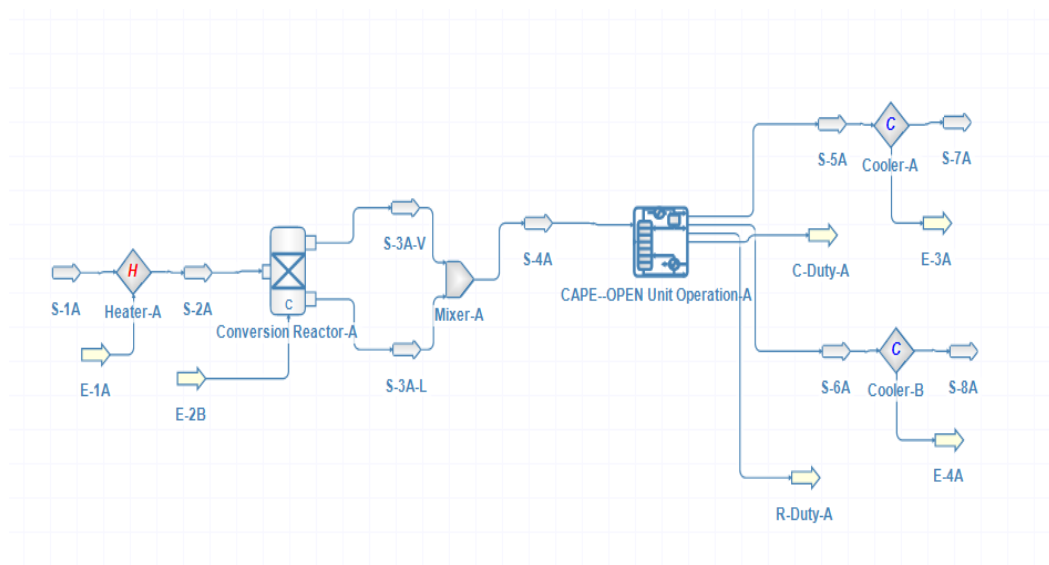

Acetic acid, also called ethanoic acid, is a colorless liquid organic compound with the molecular formula CH_3COOH . When undiluted, it is called glacial acetic acid. Vinegar is roughly 3%–9% of acetic acid by volume, which makes acetic acid the main component of vinegar, apart from water. Acetic acid has a distinctive sour taste and a pungent smell. It is primarily produced as a precursor to polyvinyl acetate and cellulose acetate. It is classified as a weak acid, as it partially dissociates in a solution. However, concentrated acetic acid is corrosive and can damage the skin. The global demand for acetic acid is about 6.5 million metric tons per year (Mt/yr), of which approximately 1.5 Mt/yr. is met by recycling, and the remainder is manufactured from methanol.

The feed was first pre-heated to a temperature of 65°C at atmospheric pressure. Then, the pre-heated feed was fed to a conversion reactor, where the conversion was assumed to be 75% with respect to acetaldehyde. The product stream was then sent to a distillation column, where acetaldehyde and oxygen were obtained as the distillate stream, and acetic acid as the bottoms. The product stream was then brought to room temperature.

URL: <https://dwsim.fossee.in/flowsheeting-project/dwsim-flowsheet-run/212>

2.90 Bioethanol Purification by Reactive Distillation

Author: Mehulkumar Sutariya

Institution: Sardar Vallabhbhai National Institute of Technology, Surat

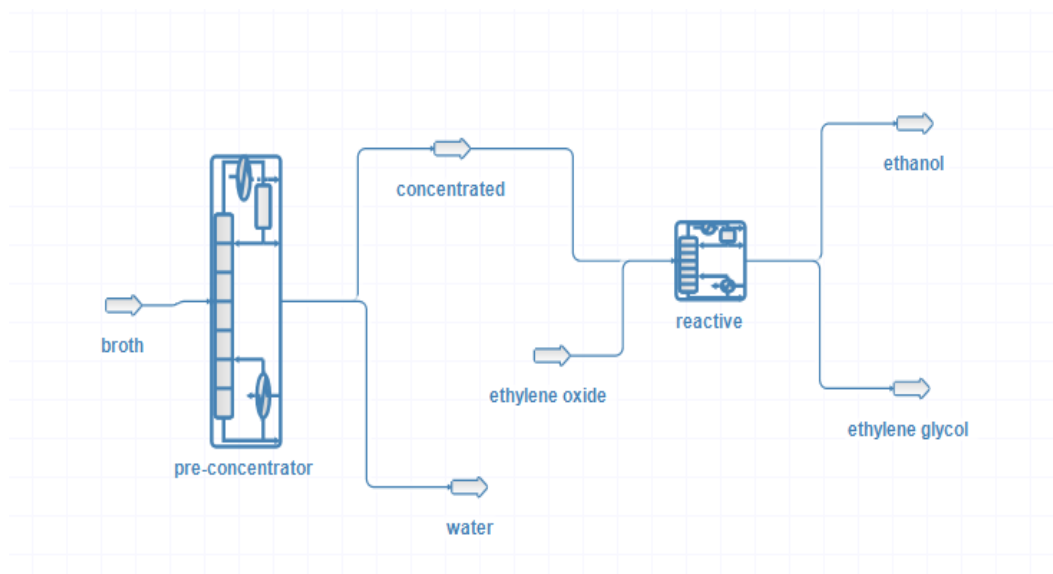

Ethanol, produced from renewable energy sources (like fermentation of sugars derived from crops containing starch, such as corn, wheat, sugar cane, sorghum plants, etc.), is one of the most promising biofuels for the future. The fermentation broth contains water and ethanol, which cannot be separated completely by simple distillation because of their tendency to create an azeotrope. For that, there are many solutions like pre-evaporation, entrainer-assisted distillation columns etc. But there is also an option available to remove water from the final concentrated azeotropic solution, through an appropriate reaction in the distillation column.

In this flow-sheet, we use two chemsep columns at different pressures; In the first column, the broth with a flow rate of 1700 kmol/hr (5 mol% ethanol, 95 mol% water) is concentrated to 85 mol% ethanol and 15 mol% water, and the excess water is removed from the bottom. This concentrated stream is fed to the next column, where one extra feed stream of ethylene oxide, with the same flow rate of water in a concentrated stream, is provided. This ethylene oxide reacts with the water present in the concentrated stream and produces ethylene glycol.

URL: <https://dwsim.fossee.in/flowsheeting-project/dwsim-flowsheet-run/207>

2.91 Effect of Thermodynamic Models on Separation of Aromatic Compounds

Author: Aakash Subramanian S.

Institution: SASTRA Deemed University, Thanjavur

The thermodynamic behavior of components is an integral part of the design of the separation process. For instance, the design and operation of the distillation column primarily depends on how accurately the phase equilibrium of the components of the solution is estimated. A process engineer should assess whether the given mixture containing components behave ideally, or, is non-ideal. If the system is found to be non-ideal, then one has to choose an appropriate thermodynamic model to estimate the phase equilibrium data. In this work, a simple distillation process was simulated with two different thermodynamic models, namely Raoult's Law (ideal system) and Peng-Robinson (PR) model (one of the non-ideal models), to illustrate that thermodynamic models play a significant role in the distillation column design.

The feed containing an equimolar mixture of benzene and chloroform, was fed to a shortcut distillation column at 25°C. Chloroform was obtained as distillate and benzene was obtained as the bottom product. Finally, the products were cooled to room temperature. Two separate sequences of the flow-sheet were

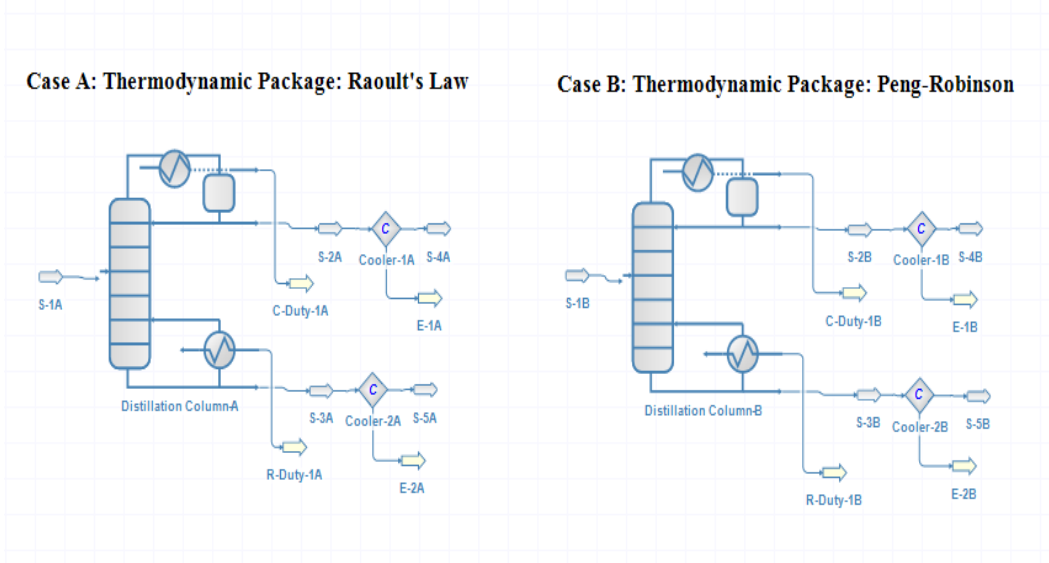

developed, such that in one case, ideal *Raoult's* law was employed and in another case, the Peng-Robinson model was employed.

URL: <https://dwsim.fossee.in/flowsheeting-project/dwsim-flowsheet-run/214>

2.92 Maximum Boiling Acetone-Chloroform Azeotropic Distillation System

Author: Bloch Sohil Y. and Mehulkumar Sutariya

Institution: Sardar Vallabhbhai National Institute of Technology, Surat

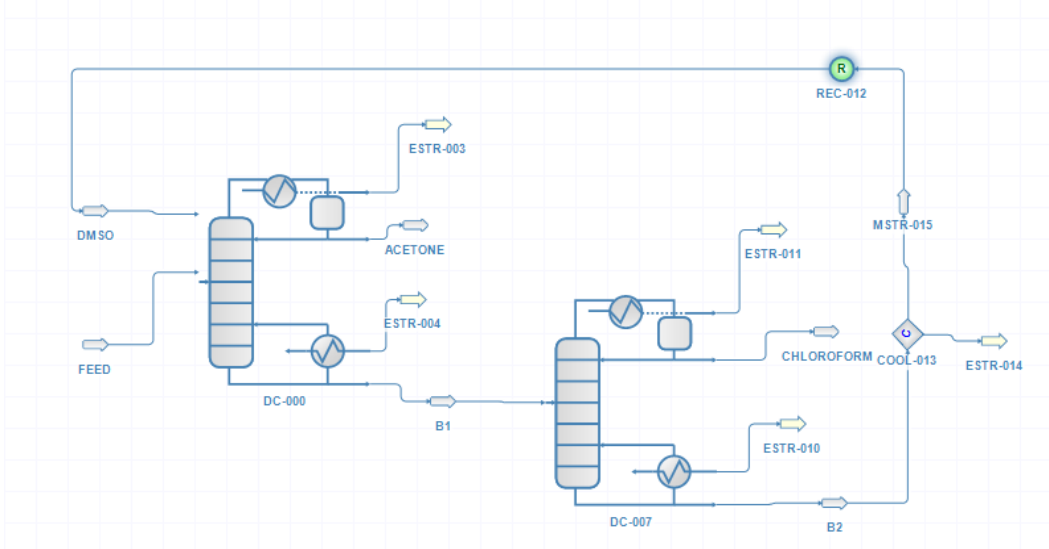

Hydrocarbons like acetone and chloroform are important raw materials in the medical area. They often require highly pure chloroform and acetone. Chloroform is widely used in pesticide formulations, as a solvent for fats, oils, rubber, alkaloids, waxes, gutta-percha, resins, as a cleansing agent, grain

fumigant, in fire extinguishers, and in the rubber industry. $CDCl_3$ is a common solvent used in NMR spectroscopy. A mixture of chlorine bleach with ethanol and acetone will produce chloroform, this reaction often gives us an azeotrope of acetone and chloroform, which must be separated out to obtain highly pure chloroform and acetone. The mixer of chloroform and acetone cannot be separated by the simple distillation column because of the small difference between their boiling points (near 5 K) and the same boiling point behavior of the azeotrope.

The flow-sheet contains two distillation columns, namely, “Extractive distillation column” and “Entrainer recovery column”. Here we use the Di Methyl Sulfoxide (DMSO) as the entrainer and a mixture of acetone and chloroform as the feed. The presence of DMSO alters the relative volatility between acetone and chloroform, and makes acetone move towards the top part and chloroform towards the bottom part of the column. The “Extractive distillation” take the entrainer and the feed and gives pure acetone as the top product and the bottom product, which has chloroform and DMSO, enter the “Entrainer recovery” column. This separates the chloroform and DMSO, and this recovered sulfolane is recycled to the extractive distillation column.

URL: <https://dwsim.fossee.in/flowsheeting-project/dwsim-flowsheet-run/215>

2.93 Pressure Swing Distillation for Separation of Tetrahydrofuran-Methanol

Author: Maradiya Jay and Mehulkumar Sutariya

Institution: Sardar Vallabhbhai National Institute of Technology, Surat

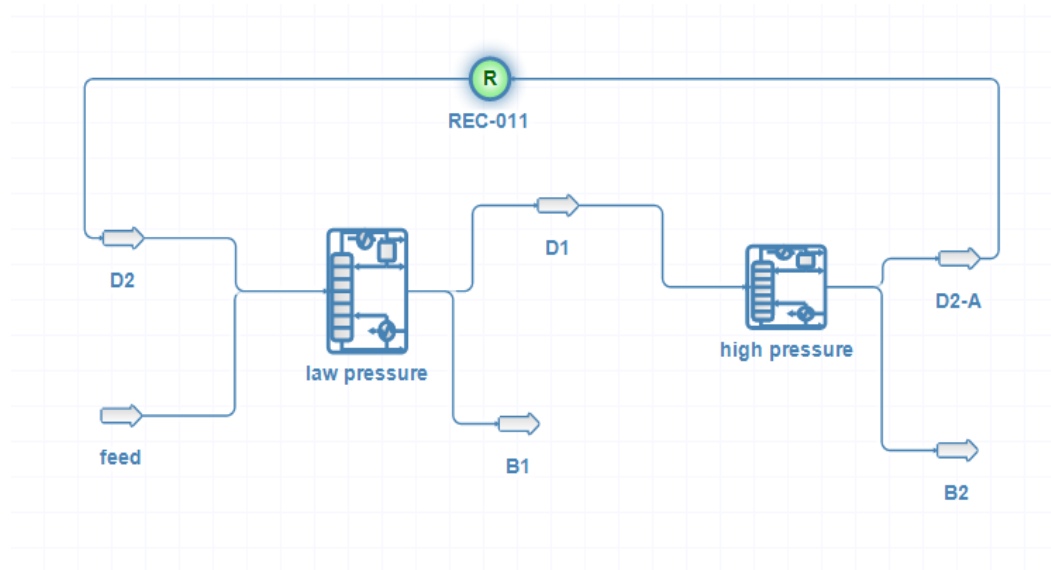

Tetrahydrofuran (THF) is one of the most commonly used solvents in the chemical and the pharmaceutical industries, due to its excellent dissolution ability. The production of steroid drugs faces the problem of separating solvents that contain THF and methanol. The separation and recycle of THF and methanol are of high economic significance and environmental importance. However, difficulty occurs in the separation process since a minimum-boiling azeotrope is formed in the binary system.

The pressure-swing-distillation (PSD) process, commonly used to separate azeotropic mixtures based on the shift of the relative volatilities and azeotropic compositions by changing the system’s pressure, is another suitable separation method for the separation of azeotropes. Efficient separation is achieved by two columns which operate at two different pressures.

At atmospheric pressure (1 atm) the azeotropic composition is near 45 mol% of tetrahydrofuran and 55 mol% methanol. At 10 atm, the azeotropic composition is changed to near 21 mol% of

tetrahydrofuran and 79 mol% of methanol. In this flow-sheet, we use two distillation columns with different pressures (1 atm and 10 atm). In the low pressure column, we enter a feed. This feed is concentrated near the azeotropic composition at 1 atm, and 99.9 mol% methanol is collected from the bottom. The top stream of the low pressure column now enters the high pressure column, where its composition is changed to the azeotropic composition at 10 atm, and the pure THF is collected from the bottom of that column. The top stream of the high pressure columns are recycled to the low pressure columns.

URL: <https://dwsim.fossee.in/flowsheeting-project/dwsim-flowsheet-run/216>

2.94 Extractive Distillation for Benzene-Acetonitrile Separation using Dimethyl Sulfoxide

Author: Bloch Sohil Y. and Mehulkumar Sutariya

Institution: Sardar Vallabhbhai National Institute of Technology, Surat

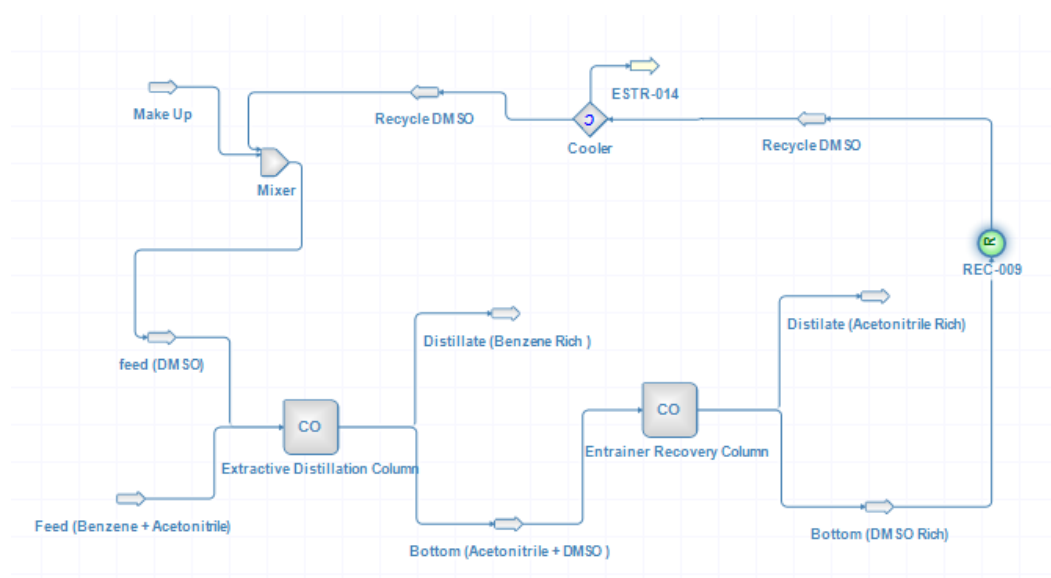

Hydrocarbons like acetonitrile and benzene are important raw materials in the manufacturing of polymeric products and as a solvent. They often require high-purity acetonitrile and benzene. The mixture of acetonitrile and benzene cannot be separated by the simple distillation column, because of the small difference between their boiling points (near 1.5 K) and the same boiling point behavior of the azeotrope. Extractive distillation is a method of separating close boiling compounds from each other, by carrying out the distillation in multiple columns, in the presence of an added liquid or liquid mixture.

The flow-sheet contains two distillation columns named “Extractive distillation column” and “Entrainer recovery column”. Here, we use the DiMethyl Sulfoxide (DMSO) as an entrainer and a mixture of acetonitrile and benzene as the feed. The presence of DMSO alters the relative volatility between acetonitrile and benzene and makes benzene move towards the top and acetonitrile towards the bottom of the column. The “Extractive distillation” takes the entrainer and feed and provides pure benzene as the top product and the bottom product, which has acetonitrile and DMSO, enter the “Entrainer recovery” column. This separates acetonitrile from the DMSO and this recovered DMSO is recycled to the “Extractive distillation”. The feed rate with the composition of compounds and other necessary data for the column, are shown in the table in the ‘Result’ section with the top and bottom products.

URL: <https://dwsim.fossee.in/flowsheeting-project/dwsim-flowsheet-run/219>

2.95 Extractive Distillation for Maximum Boiling Ethylenediamine Dehydration System

Author: Aaditya Kumar and Bloch Sohil

Institution: Sardar Vallabhbhai National Institute of Technology, Surat

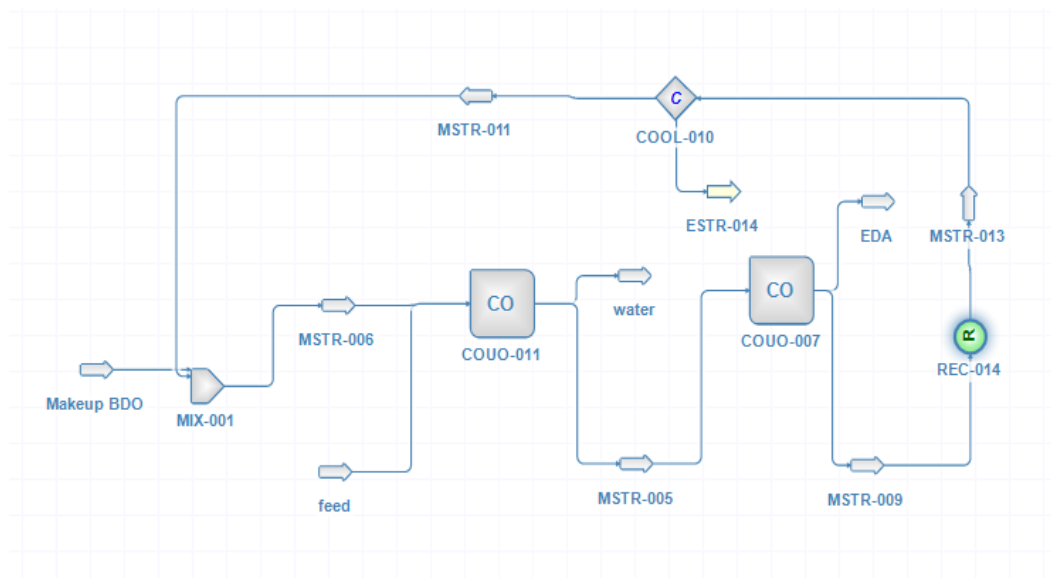

Ethylenediamine (EDA) is extensively used in organic synthesis, for the preparation of pesticides, reactive dyes, epoxy resin, etc. EDA is used in large quantities for the production of many industrial chemicals. It forms derivatives with carboxylic acids (including fatty acids), nitriles, alcohols (at elevated temperatures), alkylating agents, carbon disulfide, and aldehydes and ketones. Due to its bifunctional nature (having two amines) it readily forms heterocycles such as imidazolidines. The EDA and water mixture forms a maximum-boiling homogeneous azeotrope at atmospheric pressure, which must be separated to obtain EDA as a pure component. This cannot be achieved by separating this maximum-boiling homogeneous azeotrope via the ordinary distillation processes.

The flow-sheet contains two distillation columns, namely, “Extractive distillation column” and “Entrainer recovery column”. Here we use the 1,4-butanediol (BDO) as the entrainer and mixer of Ethylenediamine (EDA) and water as the feed. The presence of 1,4-butanediol (BDO) alters the relative volatility between EDA and water, and makes the water move towards the top part and the EDA towards the bottom part of the column. The “Extractive distillation” takes the entrainer and feed, and produces water as the top product and EDA and BDO as the bottom product, which enters to the “Entrainer recovery” column. This separates out the pure EDA at the top and the BDO at the bottom. This recovered BDO is recycled to the “Extractive distillation”. The feed rate with the composition of compounds and the other necessary data for the column are shown in the table in the ‘Results’ section with the top and bottom products.

URL: <https://dwsim.fossee.in/flowsheeting-project/dwsim-flowsheet-run/221>

2.96 Pressure Swing Distillation of Toluene - Ethanol

Author: Mehulkumar Sutariya

Institution: Sardar Vallabhbhai National Institute of Technology, Surat

Due to their excellent dissolution ability, ethanol and toluene are widely used in pharmaceutical and other chemical industries. In the production of steroid drugs, there is often a problem of separating the

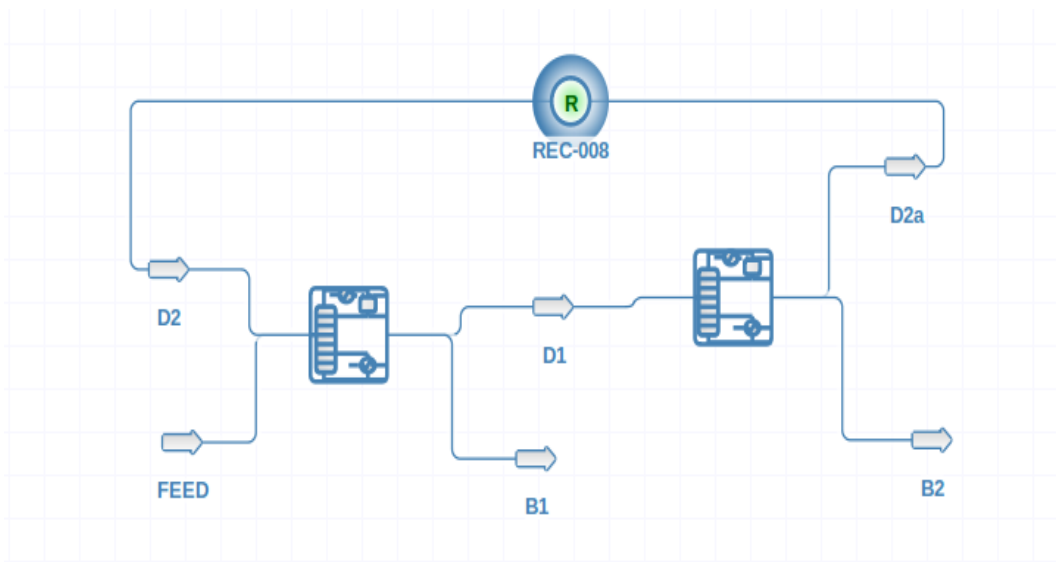

mixed solvents. It is a great challenge to effectively separate the toluene and ethanol mixture since their highly non-ideal vapor liquid equilibrium produces a minimum-boiling azeotrope.¹ When the azeotrope is pressure sensitive, pressure swing distillation is widely used in industries to separate azeotropes.

Here we use the two columns with different pressures of 0.5 atm and 11 atm respectively. These columns try to gain their respective azeotropic compositions at their column pressures, at a distillate stream. Due to this, we get a pure compound at the bottom stream. The feed enters the low pressure column, and is diluted to 0.648 wt% ethanol at a distillate from 0.72 wt% ethanol in the feed, which gives pure ethanol at the bottom. The distillate of the low pressure columns are fed to the second column, which are concentrated to 0.849 wt% ethanol at a distillate from 0.648 wt% ethanol, and it gives pure toluene at the bottom (Here dilution takes place for toluene). The distillates of the high pressure column are again recycled at the low pressure column.

URL: <https://dwsim.fossee.in/flowsheeting-project/dwsim-flowsheet-run/225>

2.97 Ethyl Acetate - Ethanol Separation via Extractive Distillation

Author: Vighnesh Candassamy Santhanamani

Institution: University of Paris-Saclay

The boiling point of Ethanol (78.37°C) and Ethyl Acetate (77.10°C) are close and thus providing Ethanol-Ethyl Acetate mixture with a low value of relative volatility. Consequently, simple distillation is inadequate to separate the compounds and extractive distillation is preferred.

The saturated feed is the Ethanol-Ethyl Acetate (0.75:0.25 mol%) at 300 kmol/hr is introduced into the Preconcentration Column (PC) to concentrate the mixture. Subsequently, the concentrated distillate from PC and the extractant Furfural are processed into the Extractive Distillation Column (EDC). Ethanol being the light key component is distilled at EDC. The bottom with Furfural and Ethyl Acetate are treated in the Entrainer Recovery Column (ERC) to recover Ethyl Acetate as the distillate. The Furfural is recycled to EDC to complete the entrainer recycle loop.

URL: <https://dwsim.fossee.in/flowsheeting-project/dwsim-flowsheet-run/228>

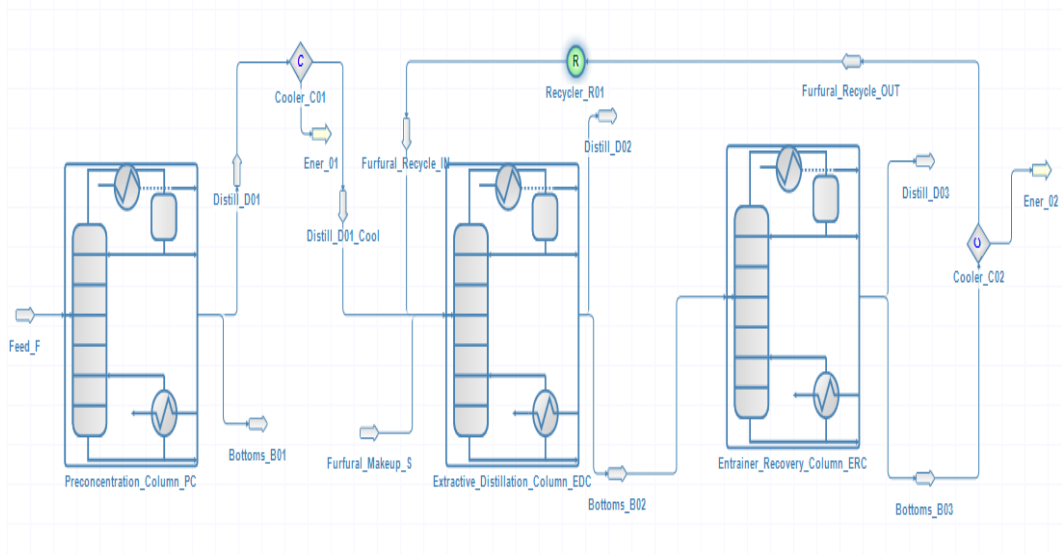

2.98 Production of Dimethyl Ether via Dehydration of Methanol using Cooled Reactor

Author: Sindha Pragneshsinh

Institution: Pacific School of Engineering, Surat

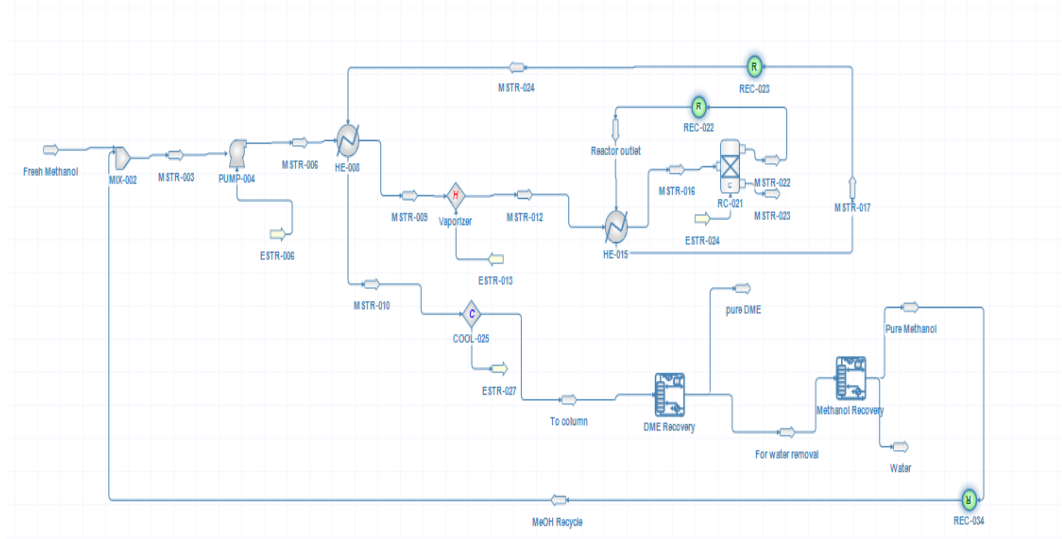

Here, simulation is carried out for the Dimethyl ether production which used for the manufacturing of Methyl Acetate followed by carbonylation.

Conversion reactor is used in which 85% conversion of methanol assumed to form DME and water. Feed stream contains 99 mol% methanol and 1 mol% water, which also merged with recycle stream of methanol found from the top product of methanol recovery column. Conversion reactor outlet temperature taken as 665K. However, feed stream is heated upto 628K using heat integration loop. High temperature stream is used as heat source to reduce energy consumption also vaporizer used to heat feed stream which also used in heat integration loop to minimize energy consumption.

Feed molar Flow and temperature are 587.128 kmol/h and 628 K respectively. Outlet stream of reactor consists of 14.86 mol% methanol, 42.97 mol% water and 42.16 mol% DME which further cooled

in heat integration loop also alternate cooler used in which stream is cool down to 351 K temperature. Here two columns were used to separate DME and methanol. For the DME separation simple distillation used which has total 22 number of staged and reactor outlet stream fed up to sage 12 in column. Condensor operated at 10 atm and reboiler operated at 10.2 atm pressure. From the column as top product 99% pure DME obtained with molar rate of 247 kmol/h and bottom product 74 mol% water and 25 mol% methanol obtained with molar rate of 339 kmol/h which futher fed up in methanol recovery column to separate water and methanol. - For methanol separation simple distillation column used which has total 27 number of stages and feed stage located at stage 16. Here as top product 99% pure methanol obtained with molar rate of 87.12 kmol/h, recovered methanol further use in process and DME Recovery column Feed stage 12 mol fraction of top product 0.001 Methanol Total stages 22 recycled to intial satge. Condensor operated at 1 atm and reboiler operated at 1.38 atm pressure. Mehtanol Recovery column Feed stage is 16, reflux ratio is 1.7 and total stages are 27. From methanol recovery column as bottom product 99% pure water removed from the methanol and water mixture.

URL: <https://dwsim.fossee.in/flowsheeting-project/dwsim-flowsheet-run/210>

2.99 Production of Ethyl Chloride from Ethylene involving Re-cycle Stream

Author: Manaswini Gowtham V, Sneha S and M Sunaina Poonacha

Institution: Ramaiah Institute of Technology, Bengaluru

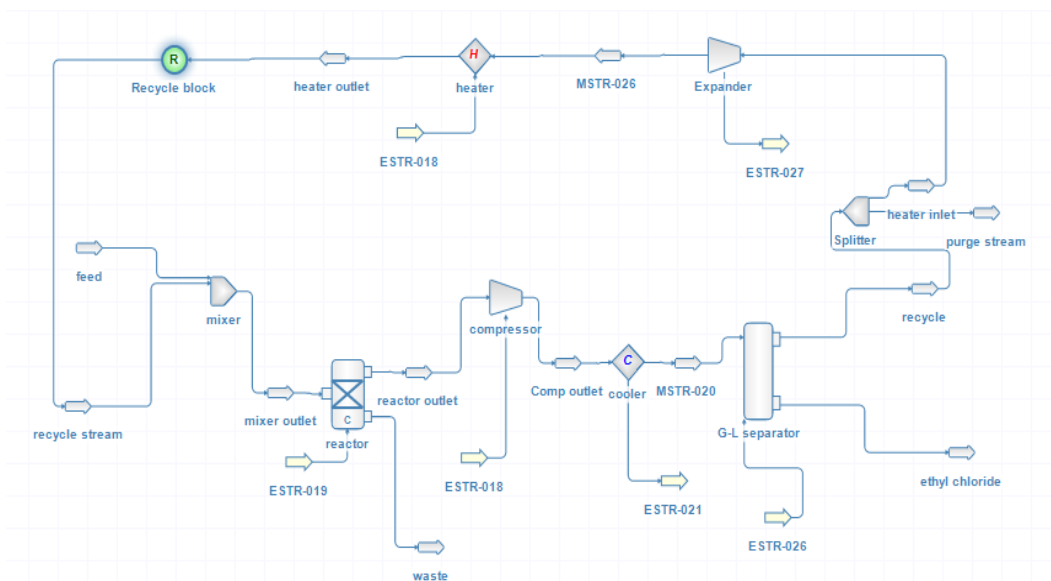

Chloroethane, better known as ethyl chloride, is used in the production of tetraethyl lead, a gasoline additive. It is a colourless, flammable gas or refrigerated liquid, mainly employed as a chemical intermediate in solvents, aerosols, and anaesthesia. It is used as a blowing agent in foamed plastics, in the production of ethyl cellulose and acts as an ethylating agent in the manufacture of dyes, chemicals and pharmaceuticals. Earlier it was formed as a by product in vinyl chloride synthesis but presently it is exclusively manufactured for a number of applications. The gas phase reaction of ethylene with hydrogen chloride to form chloroethane is an addition reaction. It proceeds with almost no by-products or side reactions and it has a high selectivity for the monochlorinated product (chloroethane).

Ethyl chloride is produced by the gas phase reaction of HCl with ethylene over a copper chloride catalyst and this is a highly exothermic reaction. The production of ethyl chloride is assumed to be a steady state process. A feed stream composed of 50 mol % HCl, 48 mol % ethylene and 2 mol% nitrogen at 100 kmol/hour, 250°C and 1 atm pressure enters the reactor (conversion reactor). A conversion of

96% was achieved and hence the unreacted reactants are to be separated from the product which is a gas. The separation of ethyl chloride from the unreacted reactants was achieved by compression to 20 bar followed by cooling to 20°C which would result in two phase formation with ethyl chloride being in liquid phase. The more volatile reactants after cooling can be easily separated from the liquid ethyl chloride. This separation was achieved using a gas-liquid separator. The unconverted reactants, namely, ethylene, HCl and nitrogen were recycled back to the mixer. To prevent the accumulation of inerts in the system, a proportion of the recycle stream was withdrawn as a purge stream.

URL: <https://dwsim.fossee.in/flowsheeting-project/dwsim-flowsheet-run/200>

2.100 New BTX Petlyuk Divided Wall Column

Author: Sindha Pragneshsinh

Institution: Pacific School of Engineering, Surat

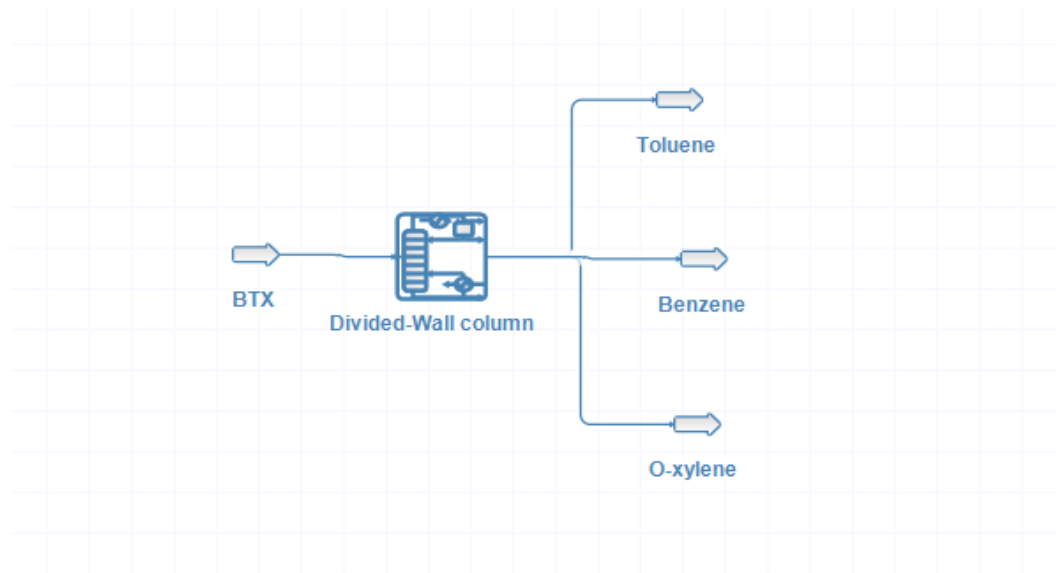

Simulation is carried out for Divided-Wall column in which three component are separated. Divided-Wall column are arranged in a such way that middle section of a single column splits using vertical wall in the vessel at an appropriate position. In these types of columns feed is introduced into the prefractionator side of the wall and sidestreams removed from the other side. Mostly sidestream contains intermediate boiling component of the ternary mixture. In Divided-Wall column in bottom vapor is split between the two sides in proportion to cross-sectional area of each side, which is fixed by the physical location of the wall. At top section of column, the liquid coming down from the rectifying section also split between two sides of the wall using a total liquid trap-out tray from which part of total liquid went to prefractionator and rest to the sidestream.

Herein simulation carried out for the separation of benzene, toluene and o-xylene. Feed contains 30 mol% benzene, 30 mol% toluene and 40 mol% o-xylene which fed in column at a rate of 3600 kmol/h [feed temperature 84.85°C]. Column has total 70 number of stages with feed stage of 21 and sidestream at stage 44. Here column designed as that the wall runs from stage 10 down to stage 34. Here, liquid split ratio and vapor split ratio taken as 0.35 and 0.65 respectively.

URL: <https://dwsim.fossee.in/flowsheeting-project/dwsim-flowsheet-run/234>

Index

- 1,4-Dioxane, 110
- 1,4-butandiol, 143
- 1-butene, 138
- 1-propanol, 136

- acetaldehyde, 114, 138
- acetic acid, 84, 90, 105, 114, 138
- acetone, 69, 74, 94, 108, 116, 141
- acetonitrile, 102, 111, 142
- air, 73, 92
- air oxidation, 118
- alkylation, 100, 138
- ammonia, 72, 88, 116, 123
- ammonia oxidation process, 123
- aniline, 135
- argon, 92
- azeotropic distillation, 81, 95

- benzene, 73, 80, 83, 90, 92, 97, 99, 100, 102, 104, 109, 120, 122, 124, 128, 133, 140, 142, 147
- biodiesel, 67
- bioethanol, 139
- BTX, 83, 104, 147
- butanol, 81, 90

- C3MR refrigeration process, 126
- carbon, 68
- carbon dioxide, 79, 82, 89, 131
- carbon monoxide, 66, 89
- carbonylation, 146
- carnot engine, 77
- catalytic hydrogenation, 97
- chloroform, 121, 140, 141
- claudé refrigeration, 96
- closed loop, 75, 100
- combustion, 68
- compression, 73, 77
- cumene, 92, 100
- cyclohexane, 97, 128

- de-humidification, 79
- debutanizer, 70, 72, 82
- deethanizer, 70
- dehydration, 98, 110, 115, 126, 132, 143, 146
- dehydrogenation, 108
- demethanizer, 70

- depropanizer, 82
- diethanalomine, 116
- diethyl ether, 117
- dimethyl ether, 146
- direct chlorination, 121
- divided wall column, 104, 147
- DMF, 83
- DMSO, 93, 94, 141, 142
- dodecane, 138

- entrain recovery, 143
- esterification, 84, 90
- ethane, 82, 86, 104
- ethanol, 95, 98, 117, 125, 132, 136, 144
- ethyl acetate, 105, 144
- ethyl chloride, 147
- ethyl formate, 125
- ethyl glycol, 110
- ethyl palmitate, 67
- ethylbenzene, 99
- ethylendiamine, 143
- ethylene, 99, 118, 121, 129, 133, 134, 147
- ethylene glycol, 139
- ethylene oxide, 110, 118, 139
- extractive distillation, 87, 93, 94, 98, 115, 125, 128, 132, 141–144

- formaldehyde, 96
- formalin, 96
- fractionation, 80
- furfural, 144

- gasoline, 72
- glycerol, 98, 132

- Haber's process, 88
- HCl, 147
- heat pump, 79
- hydration, 110
- hydrodealkylation, 90, 122, 124
- hydrogen, 66, 68, 88, 89, 97, 135, 138
- hydrogen chloride, 129
- hydrogen sulphide, 72
- hydrolysis, 85

- I-butane, 134
- IPA, 116

isobutane, 82, 86
isobutanol, 109
isopentane, 72, 82
isopropanol, 93, 108
isopropyl alcohol, 126

Linde-cycle, 65
LNG, 71, 104
LPG, 70

malaeic anhydride, 109
maximum boiling azeotropic distillation, 141
methane, 66, 68, 96, 120, 131
methanol, 69, 76, 83, 84, 89, 94, 96, 101, 102, 112, 113, 121, 128, 136, 142, 146
methyl acetate, 84
methyl cyclohexane, 87
methyl methacrylate, 112
methylal, 83, 128
mono propylene glycol, 85
monoethanalomine, 116

N-butane, 82, 86
N-butyl acetate, 90
N-heptane, 109
N-octane, 134
N-pentane, 72, 82, 119
natural gas, 70, 82, 86, 96, 107
neat operation, 113
nitric acid, 123
nitrobenzene, 135
nitrogen, 65, 88, 92, 114

octane, 138
open cycle, 75
oxygen, 92, 118, 136

p-diisopytopybenzene, 92
phenol, 87
Plate-Fin exchanger, 71
preheating, 76
pressure swing azeotropic distillation, 69, 103
pressure swing distillation, 109, 111, 121, 128, 142, 144
propane, 82, 86, 104, 119
propane cycle, 126
propylene, 92, 100, 119
propylene glycol monomethyl ether, 89
propylene oxide, 85, 89

reactive distillation, 90, 139
reforming, 131
refrigerant, 79
refrigerated purge distillation column, 130
refrigeration, 126
refrigeration cycle, 77

sour water, 72

steam reforming, 68
steam turbine, 75
stripping, 72
styrene, 133
sulphur dioxide, 136
sulphur trioxide, 136
syngas, 101
synthesis gas, 89

TEALARC, 104
tetrahydrofuran, 103, 115, 142
toluene, 80, 83, 87, 90, 104, 122, 124, 144, 147
triethanalomine, 116
tripalmitin, 67
Turton, 116

vinyl chloride, 121, 129

water, 76, 81, 93, 95, 96, 103, 110–114, 120, 125
water gas, 133

xylene, 83, 104, 147



Indian Institute of
Technology Bombay

About FOSSEE

FOSSEE (Free and Open Source Software in Education) project promotes the use of FOSS tools to improve the quality of education in our country. We aim to reduce dependency on proprietary software in educational institutions. We encourage the use of FOSS tools through various activities to ensure commercial software is replaced by equivalent FOSS tools. We also develop new FOSS tools and upgrade existing tools to meet requirements in academia and research.

The FOSSEE project is part of the National Mission on Education through Information and Communication Technology (ICT), Ministry of Human Resource Development, Government of India.

DWSIM

DWSIM is an open source CAPE-OPEN compliant chemical process simulator for Windows, Linux and MacOS X. It features a Graphical User Interface, advanced thermodynamics calculations, reactions support and petroleum characterization / hypothetical component generation tools. DWSIM can simulate steady-state, vapor-liquid (VLE), vapor-liquid-liquid (VLLE), solid-liquid (SLE) and aqueous electrolyte equilibrium processes with many Thermodynamic Models and Unit Operations.

OpenModelica

OpenModelica is an open-source Modelica-based modeling and simulation environment intended for industrial and academic usage. Modelica is a non-proprietary, object-oriented, equation based language to conveniently model complex physical systems containing mechanical, electrical, electronic, hydraulic, thermal, control, electric power or process-oriented subcomponents. OpenModelica is capable of dealing with algebraic, differential, and differential algebraic equations.



**SHROFF PUBLISHERS &
DISTRIBUTORS PVT. LTD.**

ISBN : 978-93-5213-791-6



9 789352 137916
First Edition/2018/Paperback/English